

# Vane pump, direct operated

**RE 10522/08.08**  
Replaces: 12.02

1/18

## Type PV7...A

Nominal sizes 10 to 25  
 Series 1X / 2X  
 Maximum operating pressure 100 bar  
 Displacement volume 10 to 25 cm<sup>3</sup>

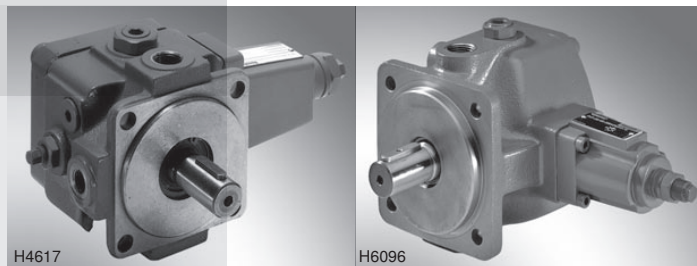

## Overview of contents

Contents	Page
Features	1
Ordering details, Preferred types	2
Symbol	2
Function, section	3
Technical Data	4
Dynamic characteristics	5
Characteristic curves	6 to 9
Unit dimensions	10
Multiple pumps	11 to 15
Engineering guidelines for multiple pumps	15
Installation guidelines	16
Engineering guidelines, Commissioning guidelines	17

## Features

- Very short control times
- Low operating noise
- Mounting and connection dimensions to VDMA 24 560/1 and ISO 3019/2
- Good efficiency
- Long service life
- Adjustable displacement volumes

Information on available spare parts:  
[www.boschrexroth.com/spc](http://www.boschrexroth.com/spc)

## Ordering details

PV7	/	R		01		A	-	*
-----	---	---	--	----	--	---	---	---

<b>Series</b>			
BS 06	= 1X		
(series 10 to 19)			
BS 20	= 2X		
(series 20 to 29)			
10 to 19; 20 to 29: installation and connection dimensions unchanged			
<b>Build size</b>	<b>Nominal size</b>		
<b>BS</b>	<b>NS</b>		
06	10 cm <sup>3</sup>	= 06 – 10	
06	14 cm <sup>3</sup>	= 06 – 14	
20	20 cm <sup>3</sup>	= 20 – 20	
20	25 cm <sup>3</sup>	= 20 – 25	
<b>Direction of rotation</b>			
Clockwise (viewed on the drive shaft)			= R
<b>Drive shaft</b>			
Cylindrical drive shaft			= A
Cylindrical drive shaft with through drive			= E
<b>Pipe connections</b>			
Suction and pressure connections			= 01
Pipe thread to ISO 228/1			

**Ordering examples:** PV7-1X/06-10RA01MA0-10  
PV7-2X/20-25RA01MA0-05

### Pump with customer specific settings:

**PV7-2X/20-25RA01MA0-10**

details in clear text:  $q_{V\ max} = 20\ l/min$ ;  $p_{zero\ stroke} = 70\ bar$

The pump will be set to the required values. The optimum operating noise will be set at the required zero stroke pressure. Without any clear text setting information the flow and the zero stroke pressure will be set to the relevant maximum values.

### Preferred types (readily available)

Type	Material No.
PV7-1X/06-10RA01MA0-05	R900561857
PV7-1X/06-10RA01MA0-10	R900563233
PV7-1X/06-14RA01MA0-04	R900919235
PV7-1X/06-14RA01MA0-07	R900919237

Type	Material No.
PV7-2X/20-20RA01MA0-05	R900950952
PV7-2X/20-20RA01MA0-10	R900950953
PV7-2X/20-25RA01MA0-05	R900950954
PV7-2X/20-25RA01MA0-10	R900950955

## Symbol

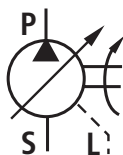

Further details in clear text

### Zero stroke pressure range <sup>2)</sup>

#### V7/06-10

05 =	25 to 50 bar
10 =	50 to 100 bar

#### V7/06-14

04 =	15 to 40 bar
07 =	40 to 70 bar

#### V7/20

05 =	25 to 50 bar
10 =	50 to 100 bar

### Adjustment device

0 =	Adjustment screw (standard)
3 = <sup>1)</sup>	Lockable rotary knob and scale (for BG 6)
3 =	Controller with lock (for BG 20)

A = direct operated

### Seals

M =	NBR - seals, suitable for mineral oil HLP to DIN 51524
K =	FKM shaft seal (other seals from NBR) suitable for use with HETG- and HEES-pressure fluids to VDMA 24 SW

<sup>1)</sup> H-key with Material No. **R900008158** is included within the scope of supply.

<sup>2)</sup> As delivered the zero stroke pressure is set to the smallest value!

**Further preferred types and standards can be found in the EPS (Standard Price List).**

## Function, section

Type PV7...A hydraulic pumps are direct operated vane pumps with an adjustable displacement volume.

The basically comprise of the housing (1), cover (2), rotor (3), vanes (4), stator ring (5), compression spring (6), adjustment screw (7) and control plate (8).

For limiting the maximum flow, the pump is fitted with an adjustment screw (9).

The driven rotor (3) rotates within the stator ring (5). The vanes (4) which are guided in the rotor (3) are pressed against the inner running surface of the stator ring (5) by centrifugal force.

### Suction and displacement process

The chambers (10) which are required for the transport of the fluid are formed by the vanes (4), the rotor (3), the stator ring (5), the control plate (8) and the cover plate (2).

The chamber volume increases as the rotor (3) rotates and the chambers fill themselves with fluid via the suction channel (S). When the largest chamber volume is reached, the chambers (10) are separated from the suction side.

As the rotor (3) continues to rotate the connection to the pressure fluid side is opened, the chambers decrease in size and force the fluid into the system via the pressure port (P).

### Pressure control

The stator ring (5) is held in its initial excentric position by spring (6). The maximum operating pressure required in the system is set at the adjustment screw (7) via the spring (6).

The pressure which builds up due to the work resistance acts on the pressure side of the inner running surface of the stator ring (5), against the force of the spring (6).

When the relevant pressure is reached, which is determined by the set spring force, the stator ring (5) is moved out of its excentric position in the direction of the zero position. The flow adjusts itself to the value which is being demanded at that time. When the highest set pressure, which has been set at the spring (6), has been reached then the pump regulates the flow back to virtually zero. The operating pressure is maintained and only the leakage fluid is replaced. Losses and heating of the fluid is thereby minimised.

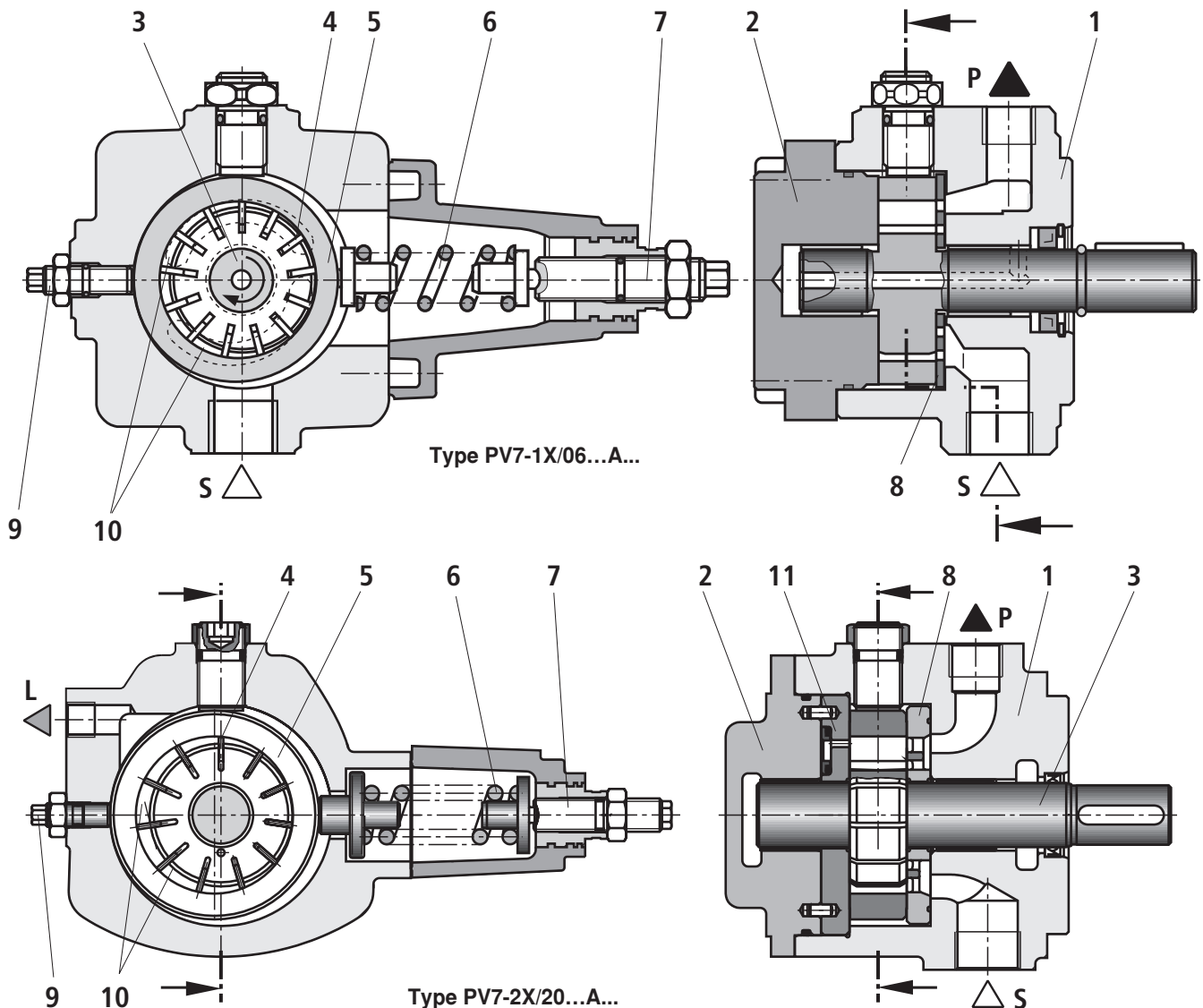

**Technical Data** (for applications outside these parameters, please consult us!)**allgemein**

Mounting style	Flange mounting		
Pipe connections	Pipe thread „G...“ to ISO 228/1		
Installation	Optional		
Shaft loading	Radial and axial forces <b>cannot</b> to taken up		
Direction of rotation	Clockwise (viewed on the drive shaft)		
Drive speed	$n$	$\text{min}^{-1}$	900 to 1800
Weight	$m$	kg	6.3                      11.4

**hydraulic**

Build size	BS		06	20
Nominal size / displacement volume	$V$	$\text{cm}^3$	10      14	20      25
Max. permissible drive torque	$T$	Nm	50	110
Operating pressure, absolute			0.8 bis 2.5	
– Inlet	$p_{\text{min-max}}$	bar	0.8 bis 2.5	
– Outlet	$p_{\text{max}}$	bar	100	70      100
– Leakage outlet	$q_{\text{max}}$	bar	2	
– Leakage flow at zero stroke (at operating pressure output = $p_{\text{zero stroke max}}$ )	$q_V$	$\text{l/min}$	1.7	2.0      2.4
Max. flow <sup>1)</sup> (at $n = 1450 \text{ min}^{-1}$ ; $p = 10 \text{ bar}$ ; $v = 41 \text{ mm}^2/\text{s}$ )	$q_V$	$\text{l/min}$	14.5	20      29      36
Pressure fluid			HLP – mineral oil to DIN 51 524 parat 2 <b>Please take the specifications stated within catalogue sheet RE 07075 into account!</b>	
Pressure fluid temperature range	$\vartheta$	$^{\circ}\text{C}$	–10 to +70, take the permissible viscosity range into account!	
Viscosity range	$v$	$\text{mm}^2/\text{s}$	16 to 160 at operating temperature Max. 800 when starting under displacement conditions Max. 200 when starting under zero stroke conditions	
Maximum permissible degree of contamination of the pressure fluid is to ISO 4406 (c) <sup>2)</sup>			Class 19/16/13 <sup>2)</sup>	

<sup>1)</sup> Flow deviations due to manufacturing tolerances of a max. of + 6% is possible

<sup>2)</sup> The cleanliness class stated for the components must be adhered too in hydraulic systems. Effective filtration prevents faults from occurring and at the same time increases the component service life.

For the selection of filters see catalogue sheets RE 50070, RE 50076 and RE 50081.

**Dynamic characteristics, measurement build-up** (measured at  $n = 1450 \text{ min}^{-1}$ ,  $v = 41 \text{ mm}^2/\text{s}$  and  $\vartheta = 50 \text{ }^\circ\text{C}$ )

The control times are valid for the measurement build-up as shown. For other set-ups and line lengths the control times will change.

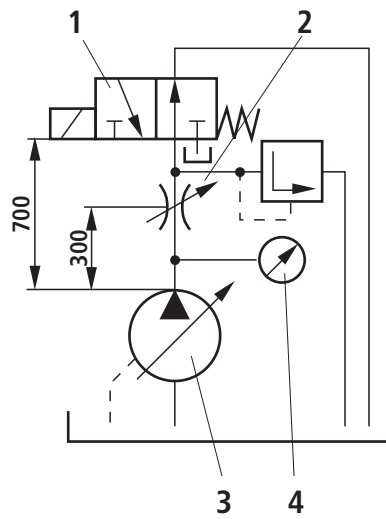

**Control times**  
(average value)

$$t_{\text{down}} / t_{\text{up}}$$

- 1 Directional valve  
(switching time 30 ms)
- 2 Throttle for setting the pressure during displacement
- 3 Hydro pump
- 4 Pressure measurement point

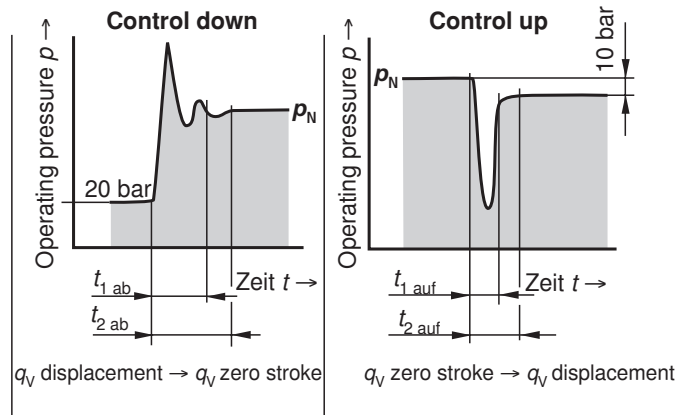

Pump type	Pressure $p_N$ bar	$t_{1 \text{ down}}$	$t_{2 \text{ down}}$	$p_{\text{max}}^{1)}$	$t_{1 \text{ up}}$	$t_{2 \text{ up}}$
...06– 10...10...	100	85	90	150	35	60
...05...	50	70	110	130	20	30
...06– 14...07...	70	80	100	130	30	50
...04...	40	65	90	100	20	35
...20–20 ...10...	100	80	125	170	25	45
...20–25 ...05...	50	60	85	120	20	40

<sup>1)</sup> Permissible pressure peaks

**Characteristic curves: type PV7/06–10, (measured at  $n = 1450 \text{ min}^{-1}$ ,  $v = 41 \text{ mm}^2/\text{s}$  and  $\vartheta = 50 \text{ }^\circ\text{C}$ )**

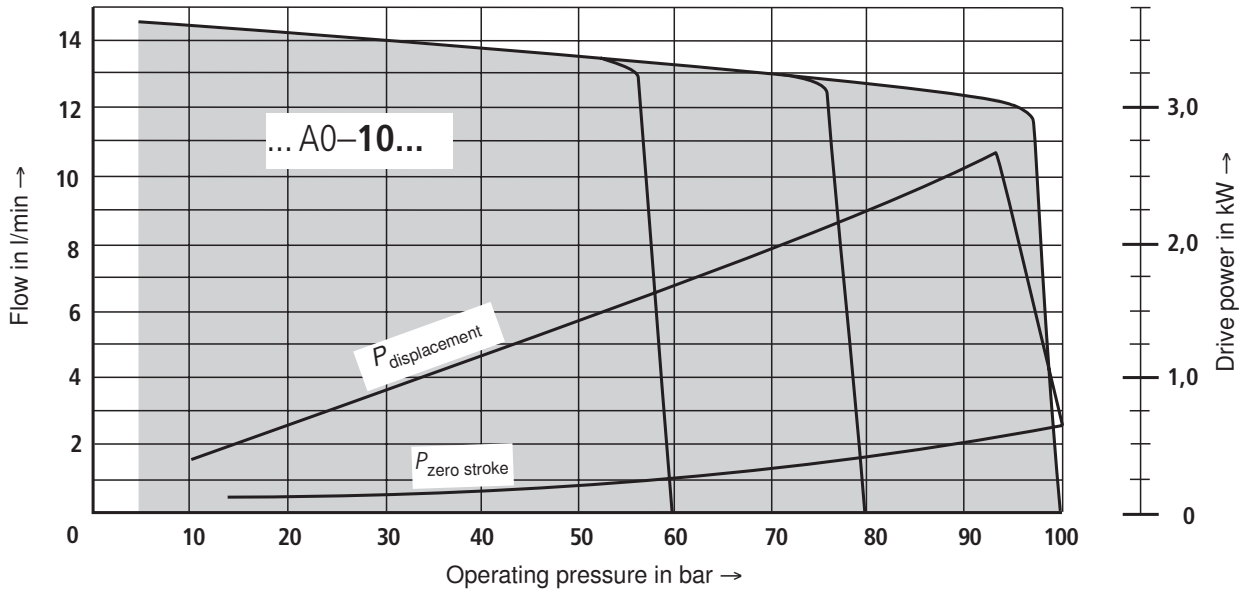
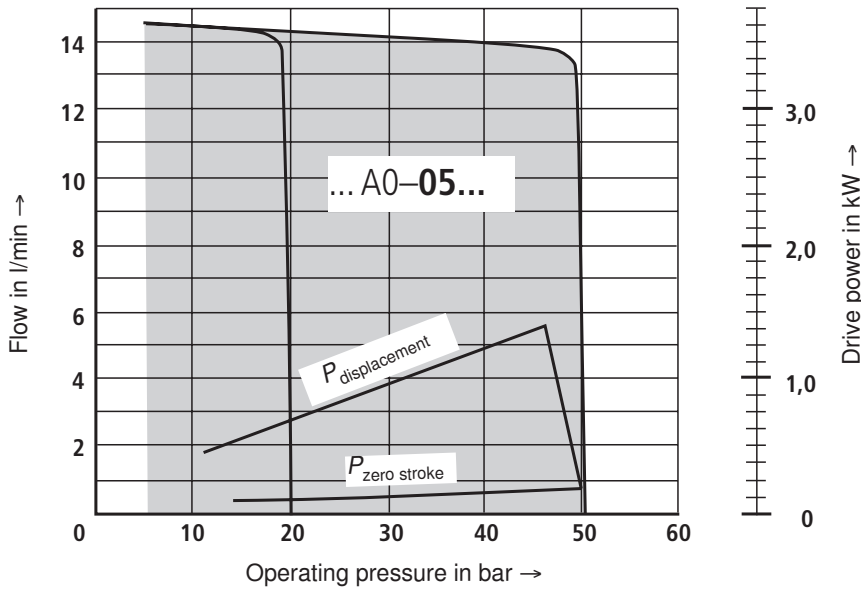

**Noise pressure level**

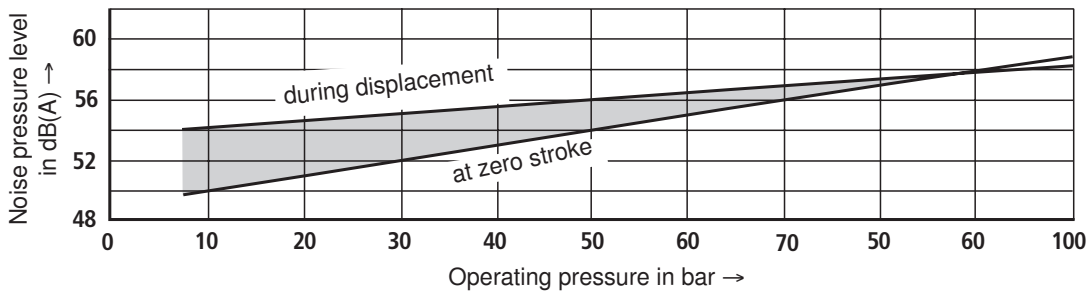

Measured in anechoic chamber to DIN 45635, page 26

Distance: Noise sensor – pump = 1m

**Characteristic curves: type PV7/06-14, (measured at  $n = 1450 \text{ min}^{-1}$ ,  $v = 41 \text{ mm}^2/\text{s}$  and  $\vartheta = 50 \text{ }^\circ\text{C}$ )**

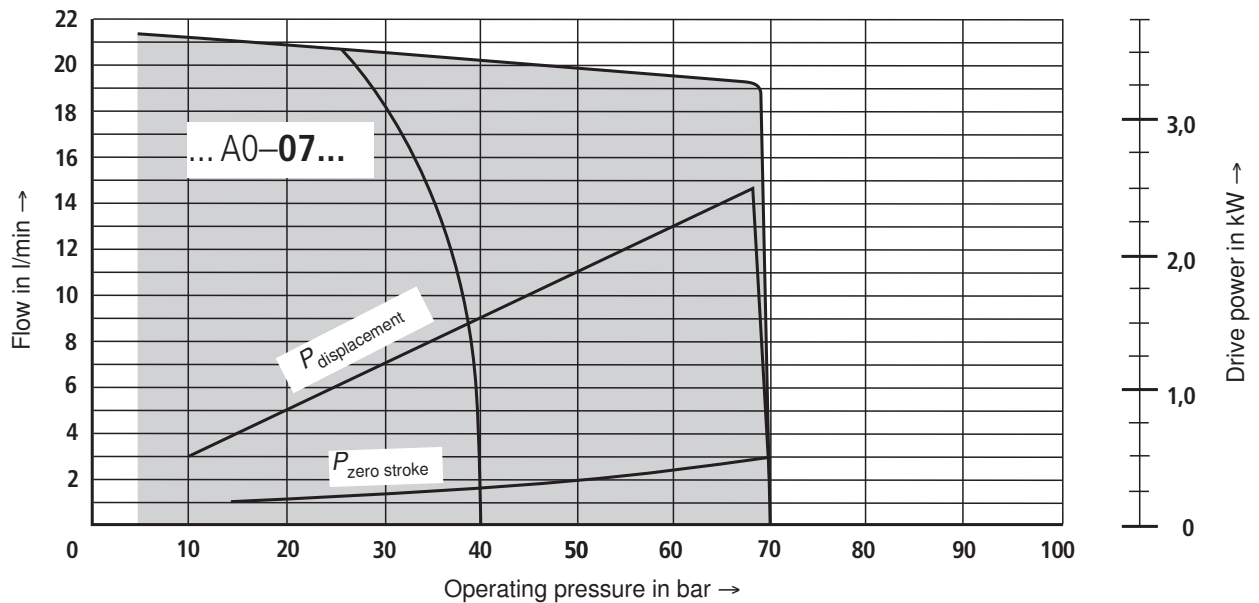
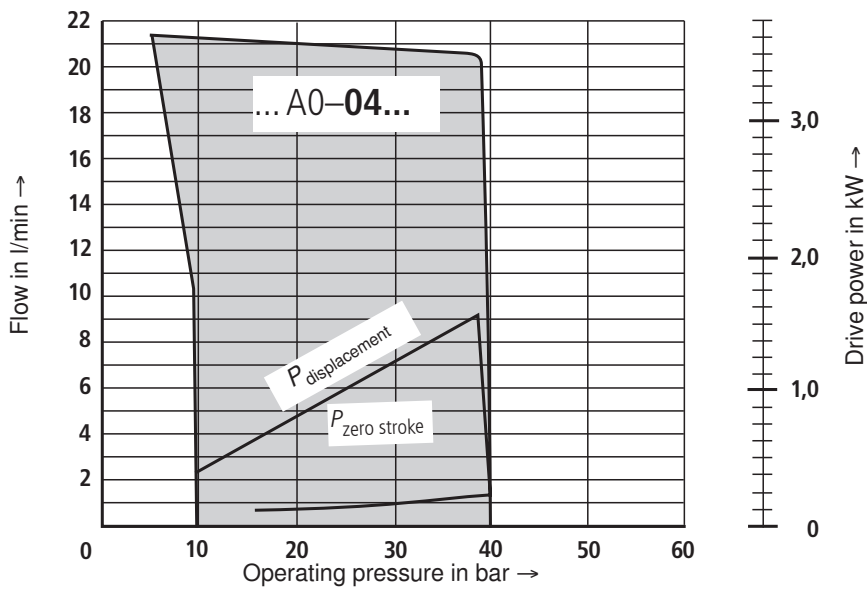

**Noise pressure level**

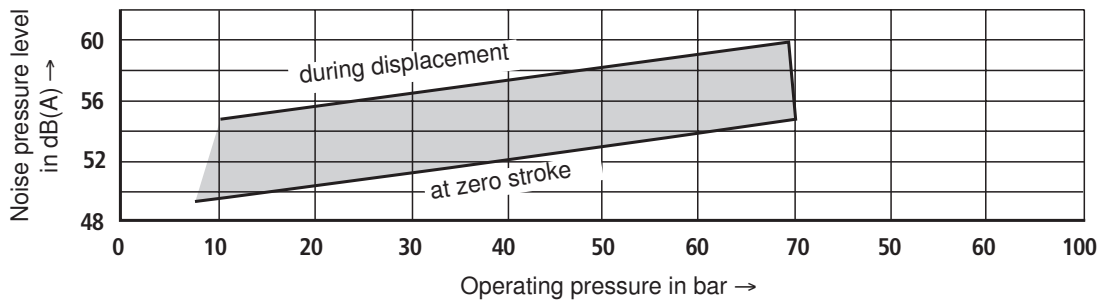

Measured in anechoic chamber to DIN 45635, page 26

Distance: Noise sensor – pump = 1 m

**Characteristic curves: type PV7/20–20, (measured at  $n = 1450 \text{ min}^{-1}$ ,  $v = 41 \text{ mm}^2/\text{s}$  and  $\vartheta = 50 \text{ }^\circ\text{C}$ )**

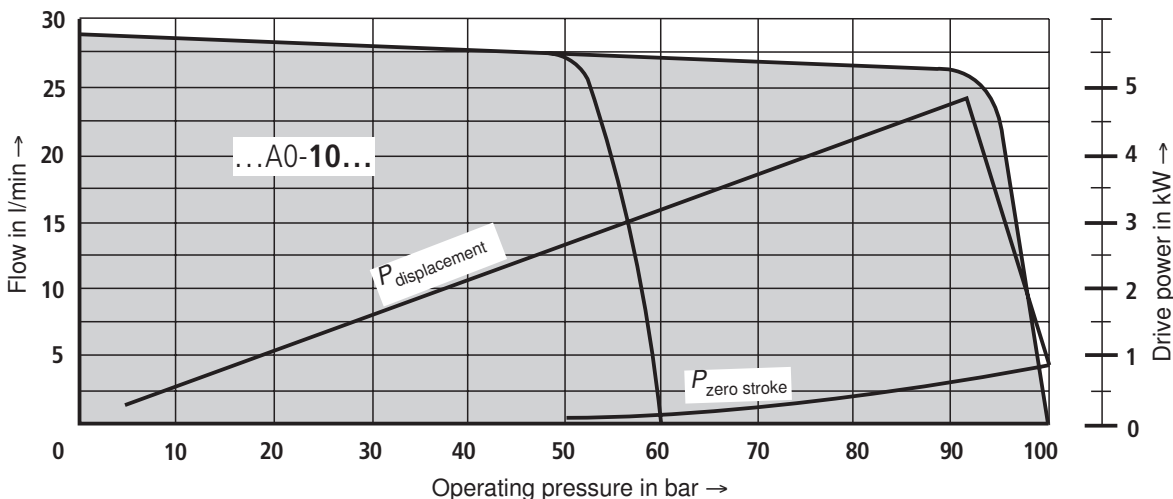
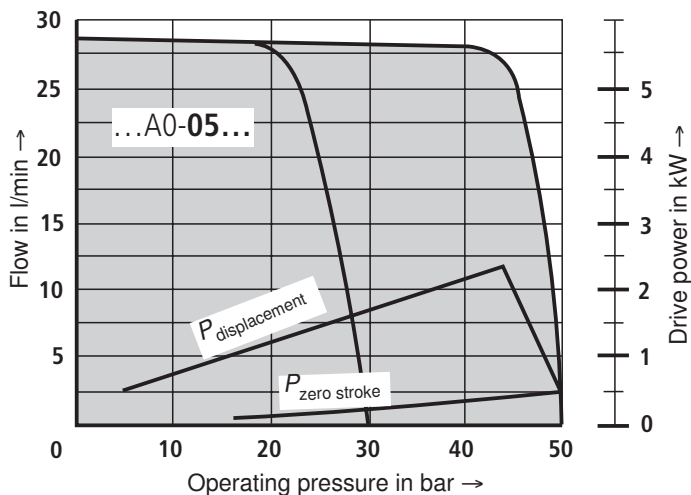

**Noise pressure level**

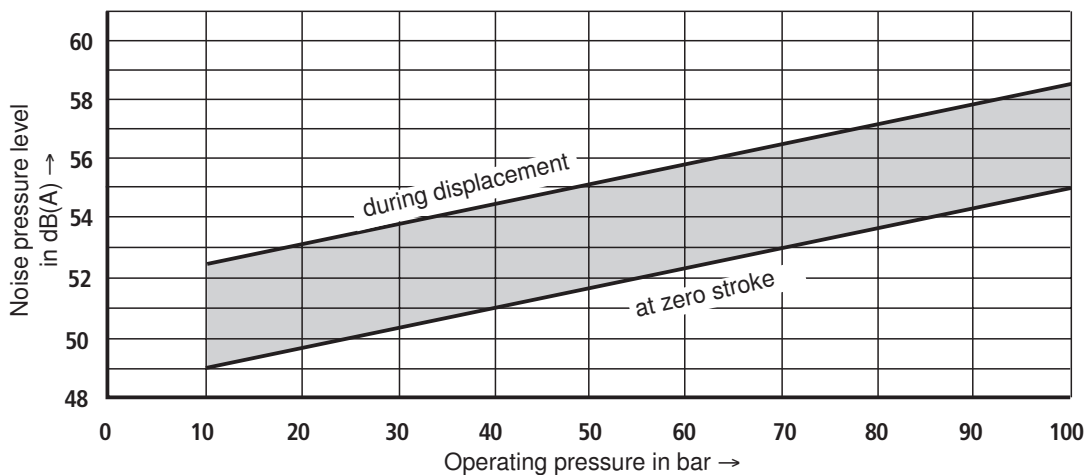

Measured in anechoic chamber to DIN 45635, page 26

Distance: Noise sensor – pump = 1m



**Characteristic curves: type PV7/20–25, (measured at  $n = 1450 \text{ min}^{-1}$ ,  $v = 41 \text{ mm}^2/\text{s}$  and  $\vartheta = 50 \text{ }^\circ\text{C}$ )**

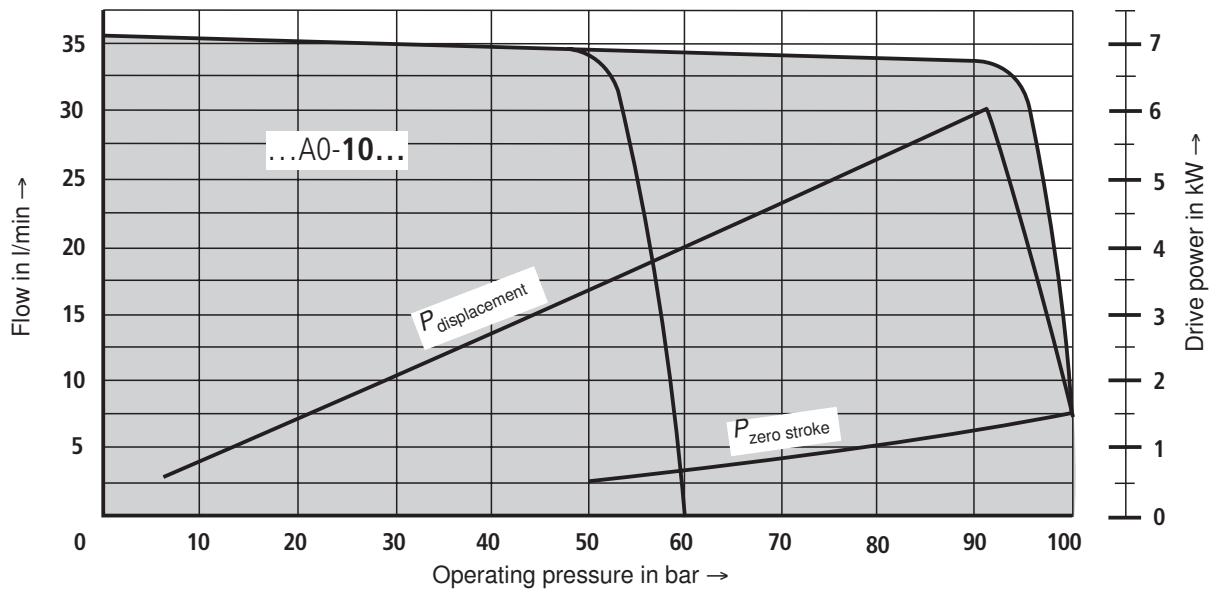
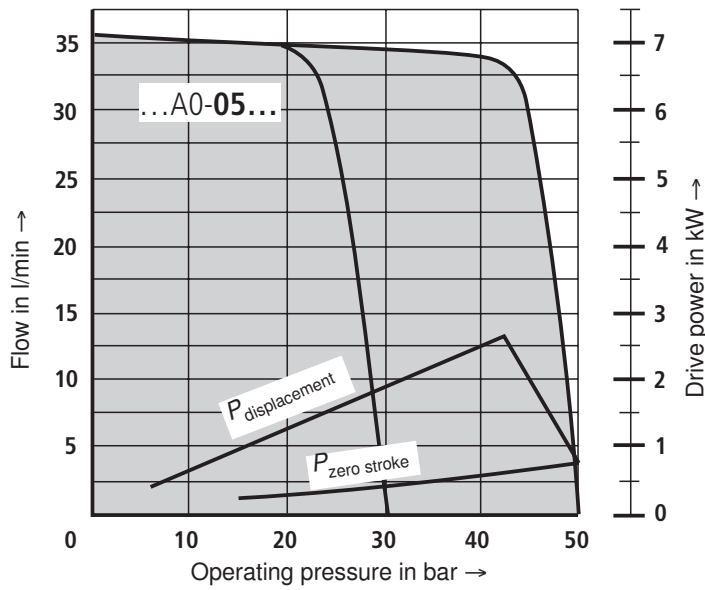

**Noise pressure level**

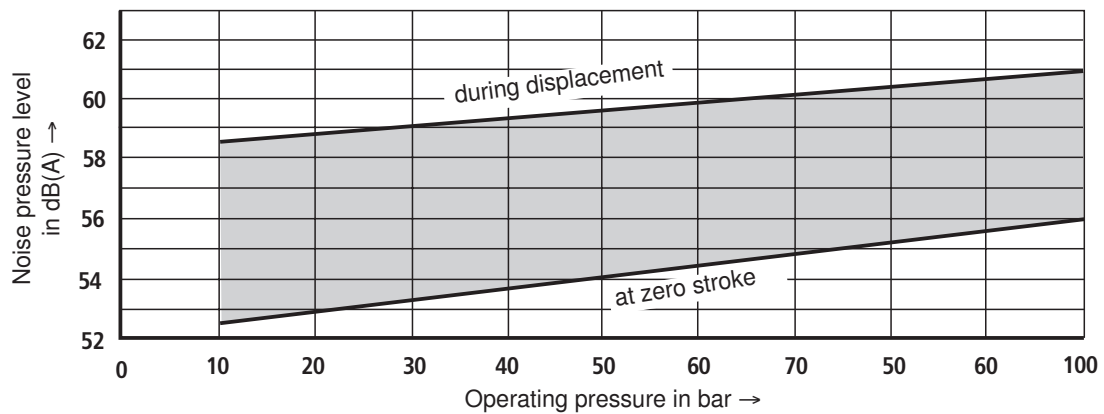

Measured in anechoic chamber to DIN 45635, page 26

Distance: Noise sensor – pump = 1 m

**Unit dimensions** (dimensions in mm)

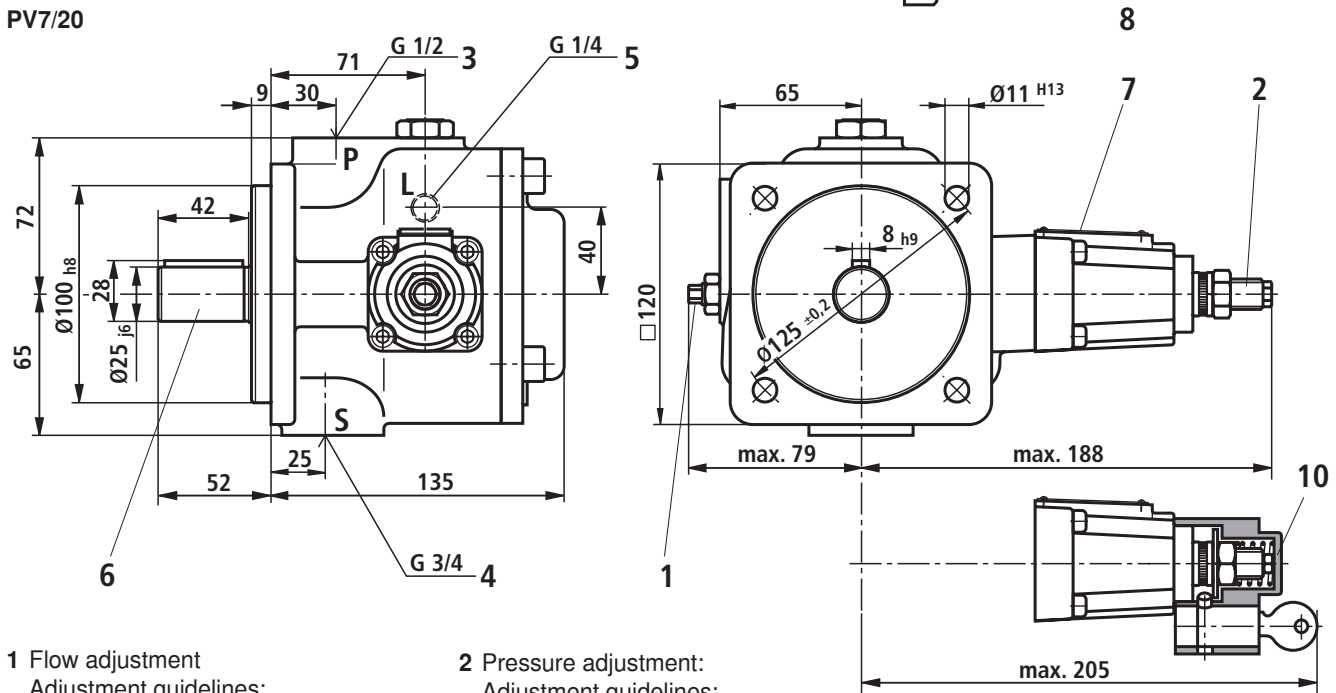
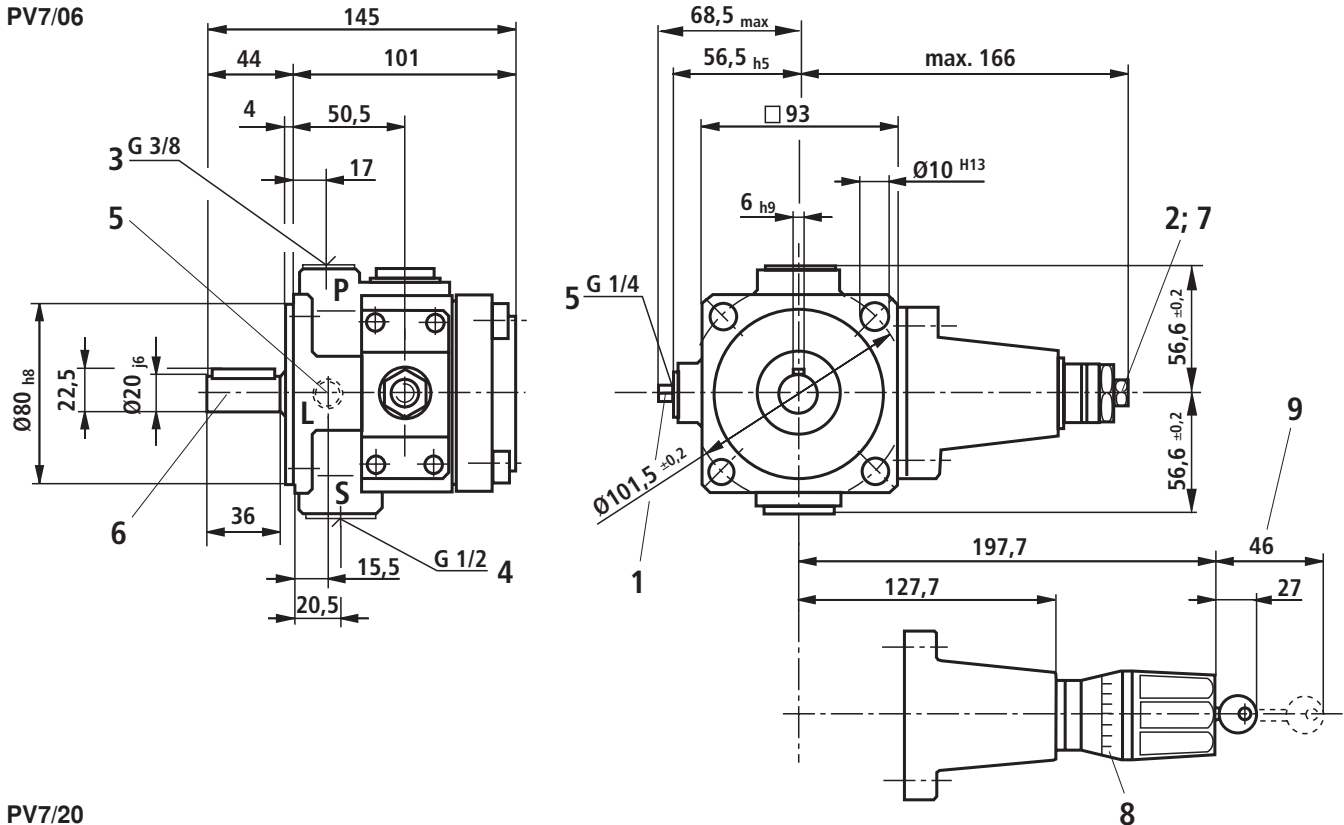

**1** Flow adjustment  
Adjustment guidelines:  
– With clockwise rotation, the flow decreases  
– With anti-clockwise rotation, the flow increases  
**Note:** The change in flow for **one** turn of the adjustment screw is for:  
PV7/06 approx. 7.5 l/min  
PV7/20 approx. 14 l/min  
each at  $n = 1450 \text{ min}^{-1}$

**2** Pressure adjustment:  
Adjustment guidelines:  
– With clockwise rotation, the operating pressure increases  
– With anti-clockwise rotation, the operating pressure decreases  
**3** Pressure connection  
**4** Suction connection  
**5** Drain port  
**6** Drive shaft

**7** Pressure adjustment via adjustment screw (standard), ordering detail ...0...  
**8** Pressure adjustment with lockable rotary knob with scale, ordering detail ...3...  
**9** Space required to remove key  
**10** Lock

## Multiple pumps

### Material No. combination parts

Rear pump	Front pump	
	V7-1X/06...RE...	V7-2X/20...RE...
PV7-1X/06...RA...	R900842849	R900540812
PV7-2X/20...RA...	-	R900540813
PGF1-2X/...RE01VU2	-	R900857585
PGF2-2X/...RJ...	R900323673	R900541210
PGP2-2X/...RJ...	R900323673	R900541210
PGH2-2X/...RR...	R900323673	R900541210
PGH3-2X/...RR...	R900323673	R900541210
AZPF...RR...	R900323673	R900541210
A10VSO10..U	R900323673	R900541210
A10VSO18..U	R900323673	R900541210
PGF3-3X/...RJ...	-	R900888267
PVV/Q1/2-1X/...RJ...	-	R900888267
PR4-1X/0,40...2,00-...WG...	-	R900541205
PR4-3X/1,60...20,00-...RA...	-	R900541207

### Ordering details for multiple pumps

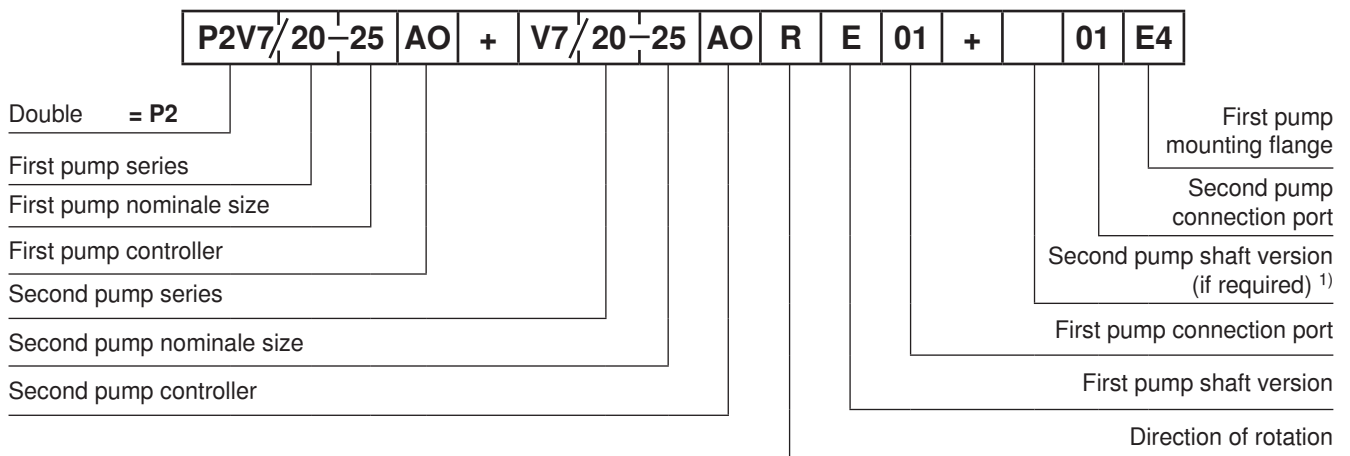

<sup>1)</sup> for PGF2 and PGF3

Triple and quadruple pumps are coded analogue!

**Ordering examples:** P2V7/20-25A0+V7/06-10A0RE01+01E4  
P2V7/06-10A0+GF2/016RE01+J20E4

**Pump combinations P2V7 + V7 (dimensions in mm)**

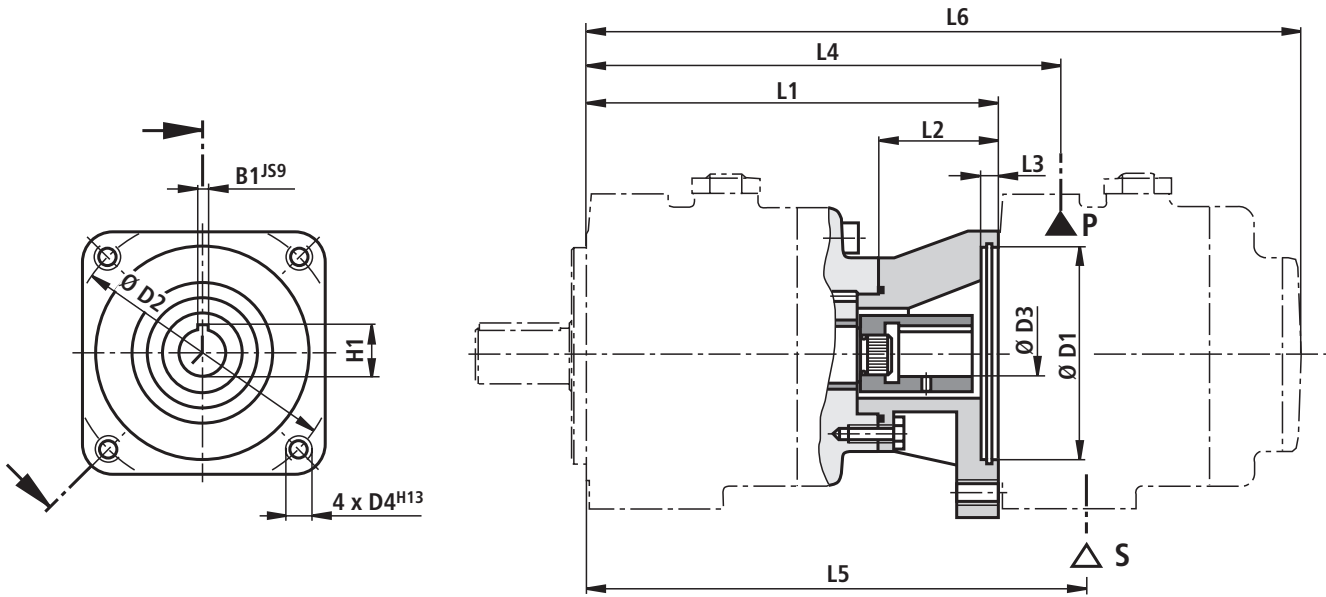

1st pump BS	2nd pump BS	L1	L2	L3	$\varnothing D1$	$\varnothing D2$	$\varnothing D3$	D4	H1	B1	L4	L5	L6
06	06	172.5	74.5	6.7	80	103	20	M8	22.5	6	190	183	273.5
20	06	185	55	8	80	103	20	M8	22.5	6	202	205.5	286
20	20	193	63	10	100	125	25	M10	28.0	8	223	218	328

**Pump combinations P2V7/06-... + GF2/GP2/GH2/GH3 (dimensions in mm)**

Mounting geometry to SAE J 744

Flange 82-2 (SAE A)

Hub 16-4 (SAE A)

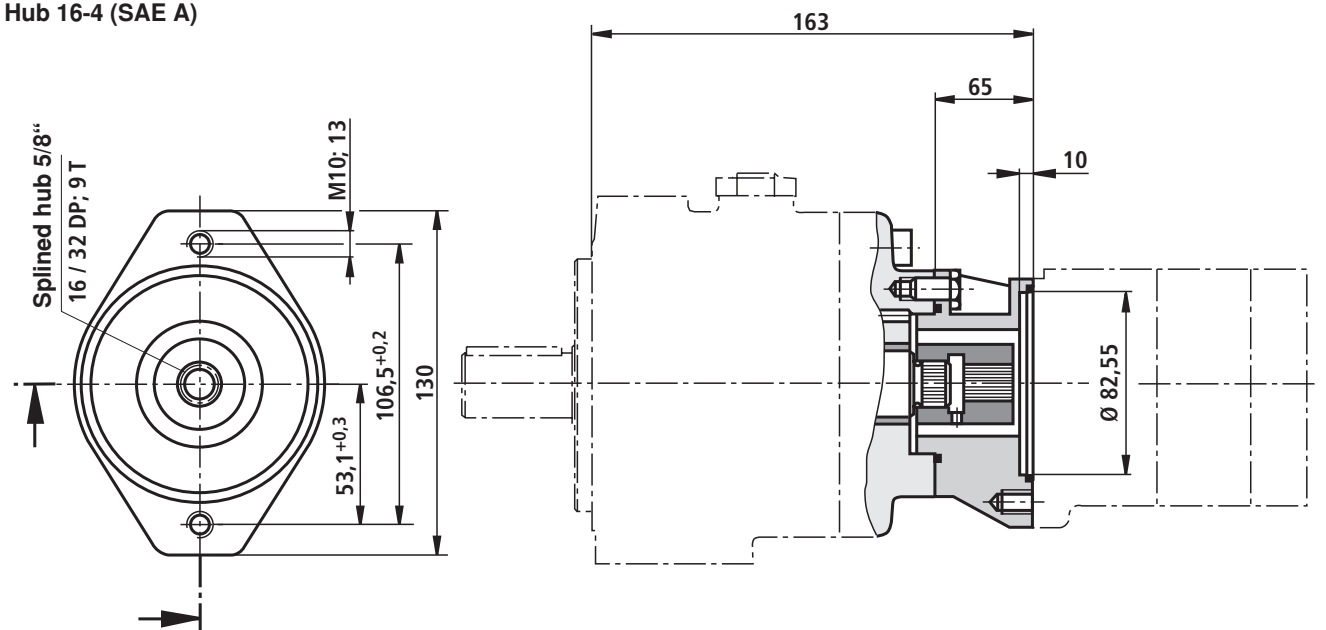

**Pump combinations P2V7/20-... + GF1... (dimensions in mm)**

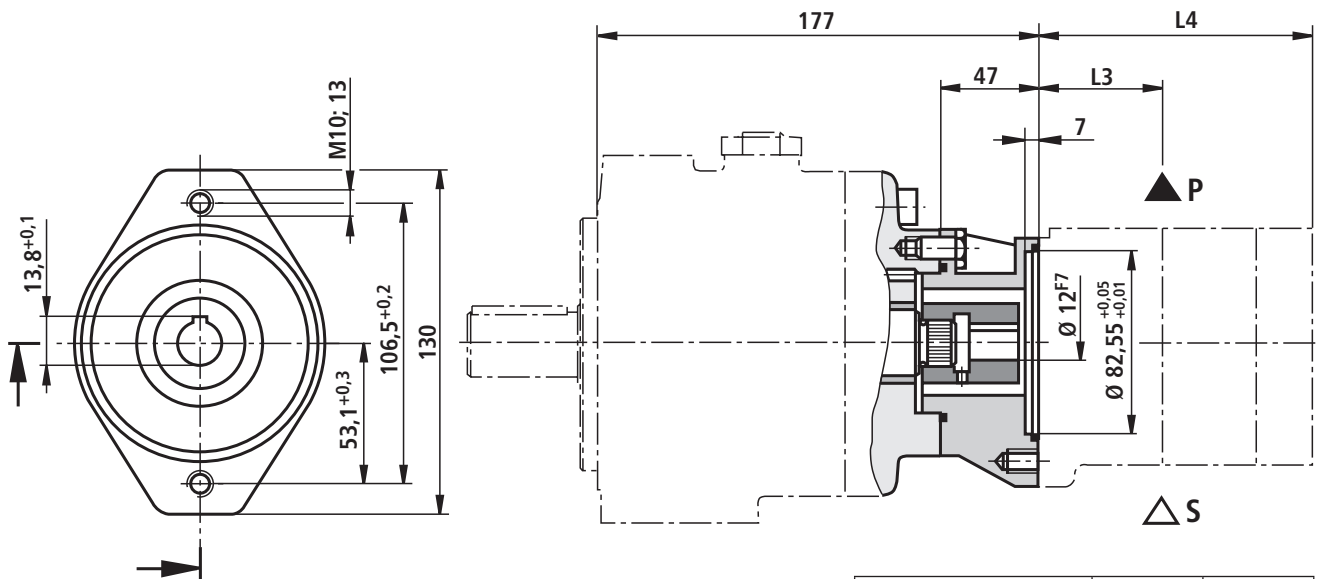

PGF1 nominal size	L3	L4
1.7	48.6	85.7
2.2	48.6	85.7
2.8	49.7	88
3.2	50.5	89.6
4.1	52.4	93.2
5.0	54.2	97

**Pump combinations P2V7/20-... + GF2/GP2/GH2/GH3 (dimensions in mm)**

Mounting geometry to SAE J 744

Flange 82-2 (SAE A)

Hub 16-4 (SAE A)

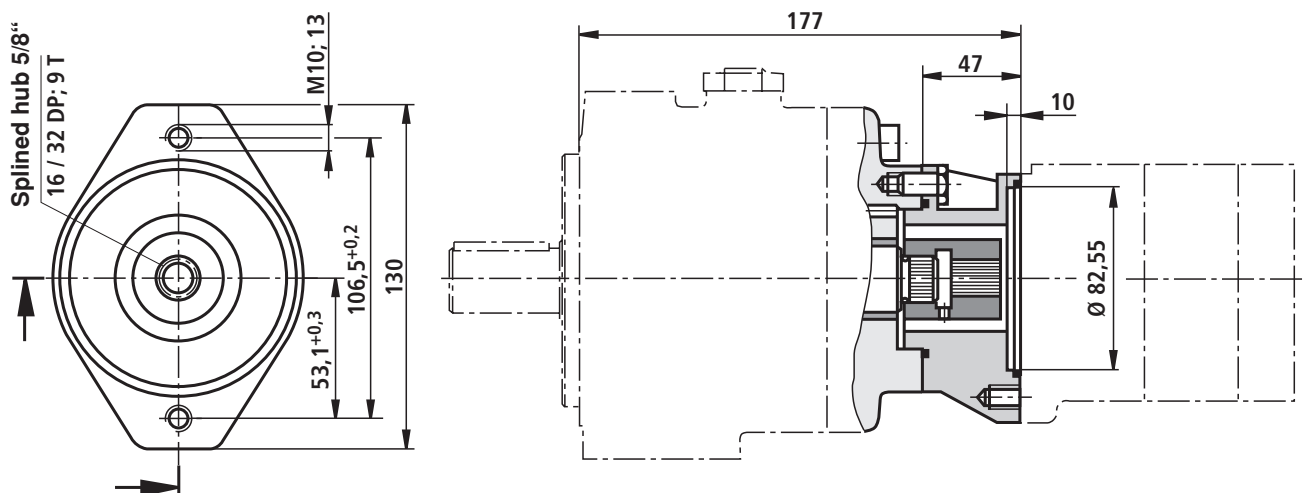

**Pump combinations P2V7/20-... + GF3/GP3/VV1/VV2/GH4 (dimensions in mm)**

Mounting geometry to SAE S 744

Flange 101-2 (SAE B)

Hub 22-4 (SAE B)

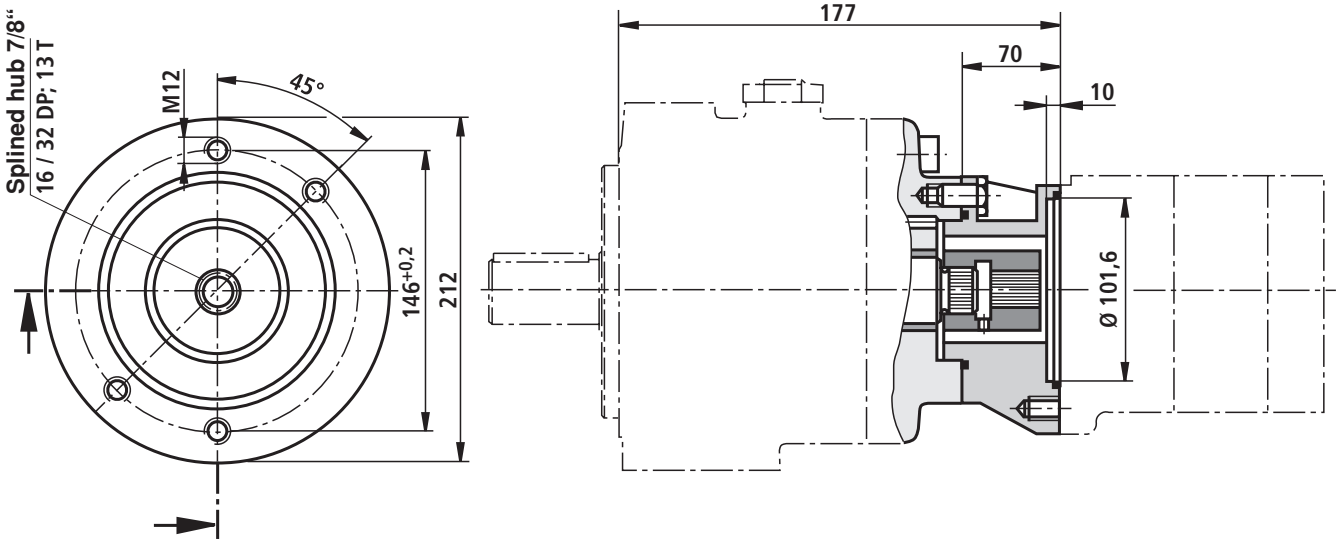

**Pump combinations P2V7/20-... + R4-Mini (dimensions in mm)**

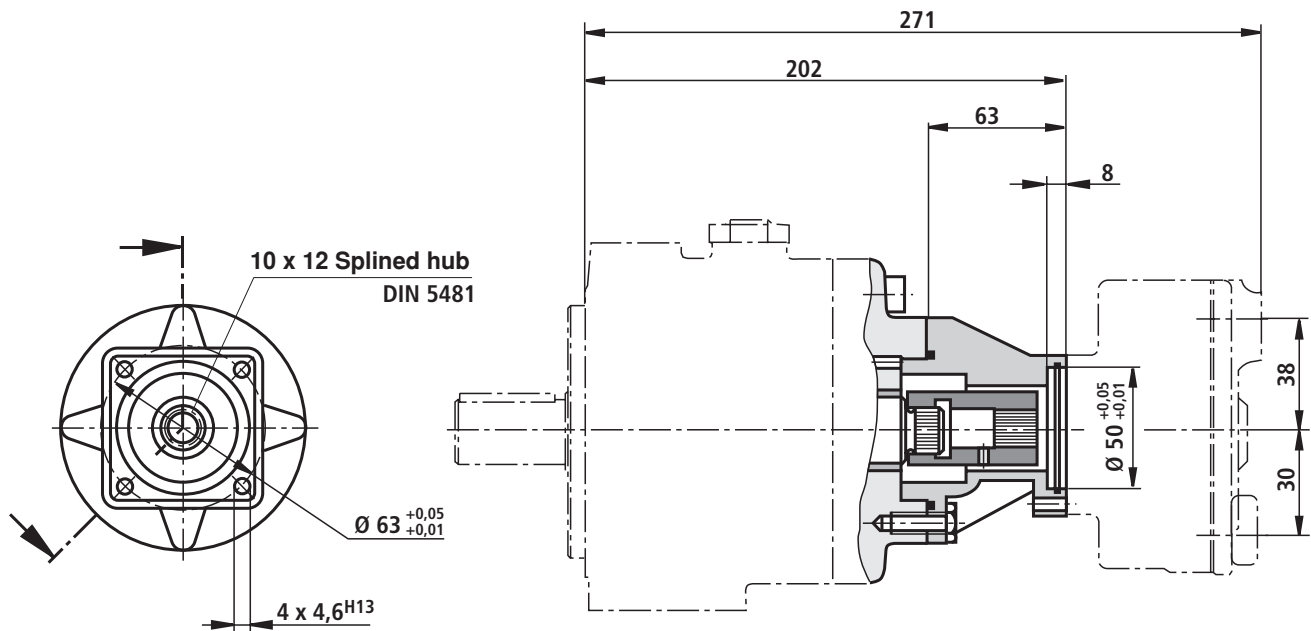

**Pump combination P2V7/20-... + R4-Standard (dimensions in mm)**

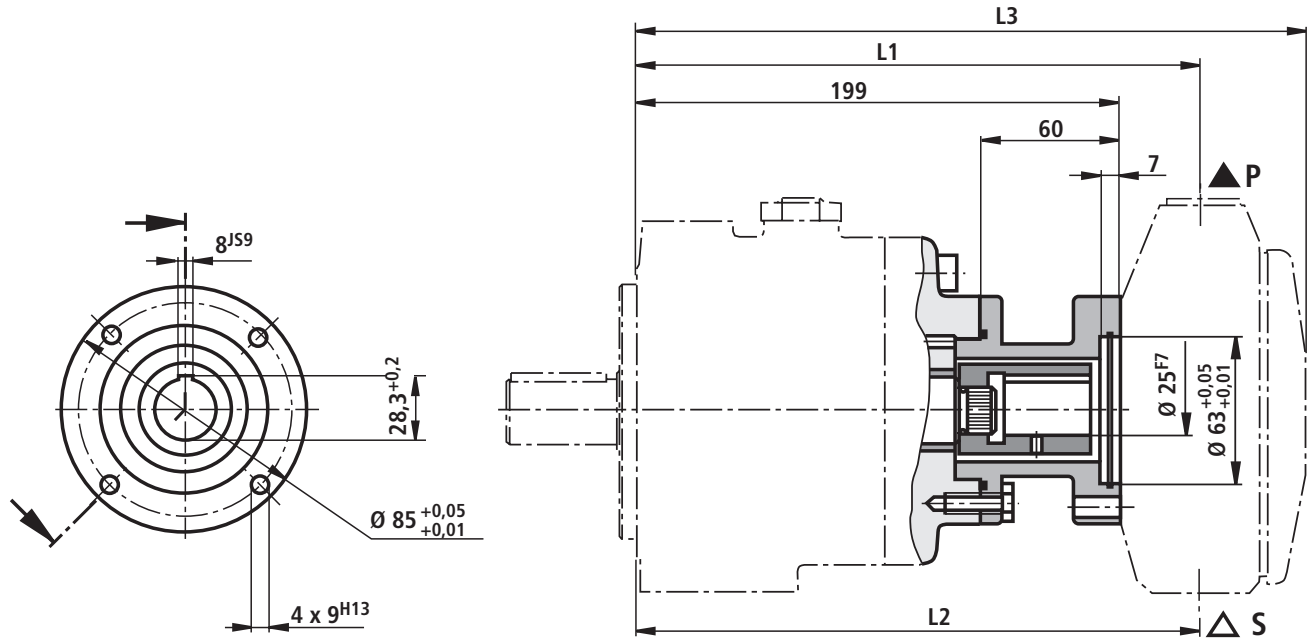

L1		L2		L3	
3/5 pistons	10 pistons	3/5 pistons	10 pistons	3/5 pistons	10 pistons
237	237	237	246	284,5	318

**Engineering guidelines for multiple pumps**

- The general technical data is the same as with the single pumps (see page 4).
- The pump with the higher load (pressure x flow) should be the first pump stage.
- When combining several pumps, the torques produced can reach excessively high values. The sum of the torques must not exceed the permissible values (see table)

**Single pump**

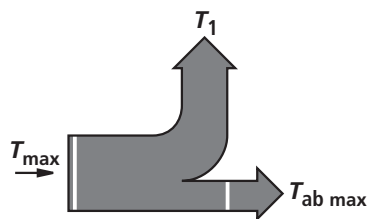

**Combination pump**

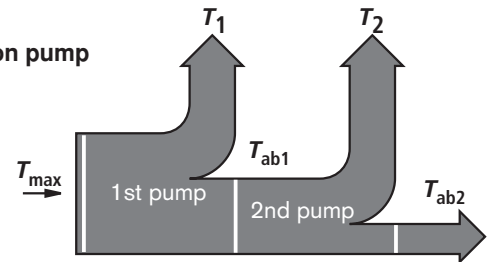

PV7 Build size	Max. permissible	
	Drive torque $T_{max}$	Output torque $T_{from max}$
06	50	30
20	110	70

$$T = \frac{\Delta p \cdot V \cdot 0.0159}{\eta_{hydr.-mech.}} \text{ (Nm)}$$

$$T_{1,2} = \frac{100 \cdot 25 \cdot 0.0159}{0.85} \text{ (Nm)}$$

$$T_{1,2} = 46.8 \text{ Nm} \leq T_{ab max}$$

$$T = T_1 + T_2 = 93.5 \text{ Nm} \leq T_{max}$$

**Calculation example:**

- $V$  = Displacement volume in  $\text{cm}^3$
- $\eta_{hydr.-mech.}$  = Hydraulic mechanical efficiency
- $T$  = Torque in Nm
- $\Delta p$  = Pressure in bar

The combination pumps P2V7/20-25.. + V7/20-25.. can be operated on the basis of the calculated data.

## Installation guidelines

### Fluid reservoir

- Match the service capacity of the reservoir to the operating conditions.
- The permissible fluid temperature must not be exceeded, if required, provide a cooler!

### Lines and connections

- Remove protective plugs from the pump.
- We recommend the use of seamless precision steel pipes to DIN 2391 and removable pipe connections.
- Select the inside diameter of the pipes according to the ports.
- Thoroughly clean pipes and fittings before assembly.

### Piping recommendations (dimensions in mm)

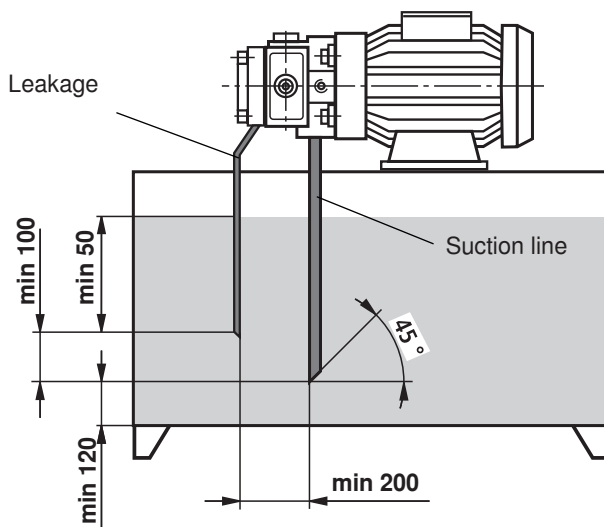

- The leakage line is to be so fitted that the pump cannot drain!
- **Under no circumstances** must leakage and return fluid be directly taken up by the pump!

### Filter

- Whenever possible, use return line or pressure filters.  
(Suction filter only in conjunction with low pressure switch/clogging indicator)

### Pressure fluid

- Please take the specifications stated within catalogue sheet RE 07075 into account.
- We recommend brand name fluids.
- Do not mix hydraulic fluids of different types since this can result in decomposition and deterioration of the lubricating quality.
- The fluid must be replaced at regular intervals according to the operating conditions. In connection with this, the tank must also be cleaned of residues.

### Antrieb:

E-Motor + Pumpenträger + Kupplung + Pumpe

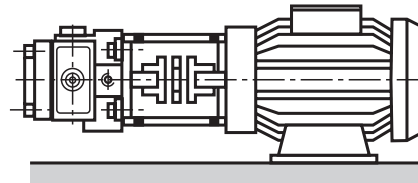

- keine Radial- und Axialkräfte auf die Pumpen-Antriebswelle zulässig!
- Motor und Pumpe müssen exakt fluchten!
- drehelastische Kupplung verwenden

### Installation position

- Horizontal position preferred

#### B3

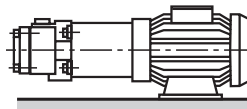

#### B5

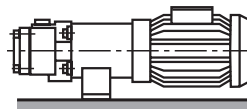

#### V1

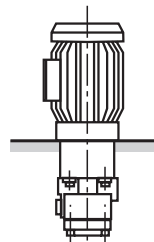



## Engineering guidelines

---

Comprehensive instructions and proposals can be found in the Hydraulic Trainer, volume 3 RE 00281, „Planning and design of hydraulic power systems“.

When using vane pumps we recommend that the following guidelines are partially taken into account.

### Technical data

All the technical data are dependent on manufacturing tolerances and are valid with certain operating conditions.

Please therefore take into account that minor variations are possible and technical data can be affected by differing conditions (e.g. viscosity).

### Characteristic curves

Characteristic curves for flow and absorbed power.

Please take into account when dimensioning the drive motor the maximum possible application data.

### Noise

The noise pressure level values given on pages 5 to 7 are measured according to DIN 45 635 part 26. This means that only the noise emission of the pump is given. Ambient influ-

ences (such as place of installation, piping, etc.) are not taken into consideration. The values only refer to one pump.

**⚠ Attention!** The power unit design and the influences at the unit's final place of installation, in general, result in the fact that the noise pressure levels lie 5 to 10 dB(A) higher than that of the pump alone.

### Leakage fluid

On page 4 the average external leakage of the pump is stated. Please note that these values are only intended for use as engineering guidelines when defining cooler sizes and pipe sizes. When determining the size of the oil reservoir the appropriate value to be used is the zero stroke power (see pages 5 to 7). Changes in cross-section and the use of a leakage oil cooler can result in there being unpermissibly high pressure peaks in the leak-oil line.

## Commissioning guidelines

---

### Bleeding

- All of the PV7...A type vane pumps are self-priming.
- Before commissioning for the first time, the pump has to be bled so that it is protected against damage.
- During the first commissioning, we recommend that the housing is filled via the leakage connection. Take into account the filter rating! This increases operating safety and prevents wear in the case of unfavourable installation conditions.
- If the pump after approx. 20 seconds does not displace oil without any bubbles then the system has to be rechecked. After the operating values have been reached, check the pipe connections for leakage and check the operating temperature.

### Commissioning

- Check to see if the system has been carefully, correctly and cleanly assembled.
- Take into account the motor and pump direction of rotation arrows.
- Start the pump without load and let it displace oil without pressure for a few seconds in order to provide sufficient lubrication.
- On no account let the pump run without oil!

### ⚠ Attention!

- Adjustment, maintenance and servicing of the pump must only be carried out by authorised, trained and instructed personnel!
- Use only original Rexroth spare parts!
- The pump must only be operated within the permitted limits.
- The pump may only be operated in a sound condition!
- When carrying out any work on the pump (e.g. removing and refitting) switch the system to zero pressure and isolate from the mains supply!
- Unauthorised conversions and modifications which affect the safety and function of the pump are not permitted!
- Provide protective measures (e.g. coupling guard)!
- Do not remove any existing protective devices!
- The general valid safety and accident prevention regulations must be adhered to!

## Notes

---

Bosch Rexroth AG  
Hydraulics  
Zum Eisengießer 1  
97816 Lohr am Main, Germany  
Telefon +49 (0) 93 52 / 18-0  
Telefax +49 (0) 93 52 / 18-23 58  
documentation@boschrexroth.de  
www.boschrexroth.de

© This document, as well as the data, specifications and other information set forth in it, are the exclusive property of Bosch Rexroth AG. It may not be reproduced or given to third parties without its consent.

The data specified above only serve to describe the product. No statements concerning a certain condition or suitability for a certain application can be derived from our information. The information given does not release the user from the obligation of own judgment and verification. It must be remembered that our products are subject to a natural process of wear and aging.

## Notes

---

Bosch Rexroth AG  
Hydraulics  
Zum Eisengießer 1  
97816 Lohr am Main, Germany  
Telefon +49 (0) 93 52 / 18-0  
Telefax +49 (0) 93 52 / 18-23 58  
documentation@boschrexroth.de  
www.boschrexroth.de

© This document, as well as the data, specifications and other information set forth in it, are the exclusive property of Bosch Rexroth AG. It may not be reproduced or given to third parties without its consent.

The data specified above only serve to describe the product. No statements concerning a certain condition or suitability for a certain application can be derived from our information. The information given does not release the user from the obligation of own judgment and verification. It must be remembered that our products are subject to a natural process of wear and aging.

## Notes

---

Bosch Rexroth AG  
Hydraulics  
Zum Eisengießer 1  
97816 Lohr am Main, Germany  
Telefon +49 (0) 93 52 / 18-0  
Telefax +49 (0) 93 52 / 18-23 58  
documentation@boschrexroth.de  
www.boschrexroth.de

© This document, as well as the data, specifications and other information set forth in it, are the exclusive property of Bosch Rexroth AG. It may not be reproduced or given to third parties without its consent.

The data specified above only serve to describe the product. No statements concerning a certain condition or suitability for a certain application can be derived from our information. The information given does not release the user from the obligation of own judgment and verification. It must be remembered that our products are subject to a natural process of wear and aging.