

## Compact power modules KE, K and KS series

**RE 18306-02**

Edition: 02.2016

Replaces: 12.2014



---

**Contents**

Ordering Details	2
General Technical Data	6
Compact Power Module Type	9
A.C. Electric Motors	10
D.C. Electric Motors	16
Central Manifold	32
Built-in Valves	61
Gear Pumps	80
Oil Tanks	82
Mounting position	93
Modular Stackable Elements	95
Accessories	127

## Ordering Details for Compact Power Modules with A.C. Motor

01	02	03	04	05	06	07	08	09	10	11	12
---	-	-	-	-	-	-	-	-	-	-	-

<b>Family</b>											
01	Power module type										KE K KS

<b>Power module type of motor</b>											
02	Without motor										0
	With 3ph motor										2
	With 1ph motor										3

<b>A.C. Electric motor</b>											
03	In the Power Module KE-KS type is possible to assemble every code of AC motor shown in the catalogue. In the Power Module K type is not possible to assemble AC Compact Mounting Style motors. (See pag.10-15)										

<b>Junction Elements</b>											
04	The code of the Junction Element is showing in the page after the selected AC motor.										

<b>Central Manifold with Pressure range Relief Valve + Request Setting of the Relief Valve in Bar</b>											
05	Select the required Central manifold with the required pressure range of the Relief valve and put the required setting in bar beetwen bracket.										

<b>Built-in Valves</b>											
06	Insert the codes of the required valves following the number of the cavity in the Central Manifold (see page after the selected Central Manifold).										

<b>Coil Model and Connector</b>											
07	In case of selection of Solenoid Built-in Valve choice the required coil Voltage and the required Connector. (See page 72-73)										

<b>Gears pump</b>											
08	Is possible to select the required pump between Standard Version and Cast iron cover version. (See page 80)										

<b>Oil Tank</b>											
09	Select the required Oil Tank. (See pag.82-92)										

<b>Mounting Position and Mounting Brackets</b>											
10	Select the required working position of the Power Module and the position of the therminal box and Oil Filler cap in case of mounting position V1. If needed select the Mounting Bracket. (See pag.93-94)										

<b>Modular Stackable Elements</b>											
11	If needed select the additional Modular Stackable Elements.										

<b>Accessories</b>											
12	If needed select the additional Accessories.										

**Example of Ordering Details for Compact Power Modules ME with A.C. Motor**

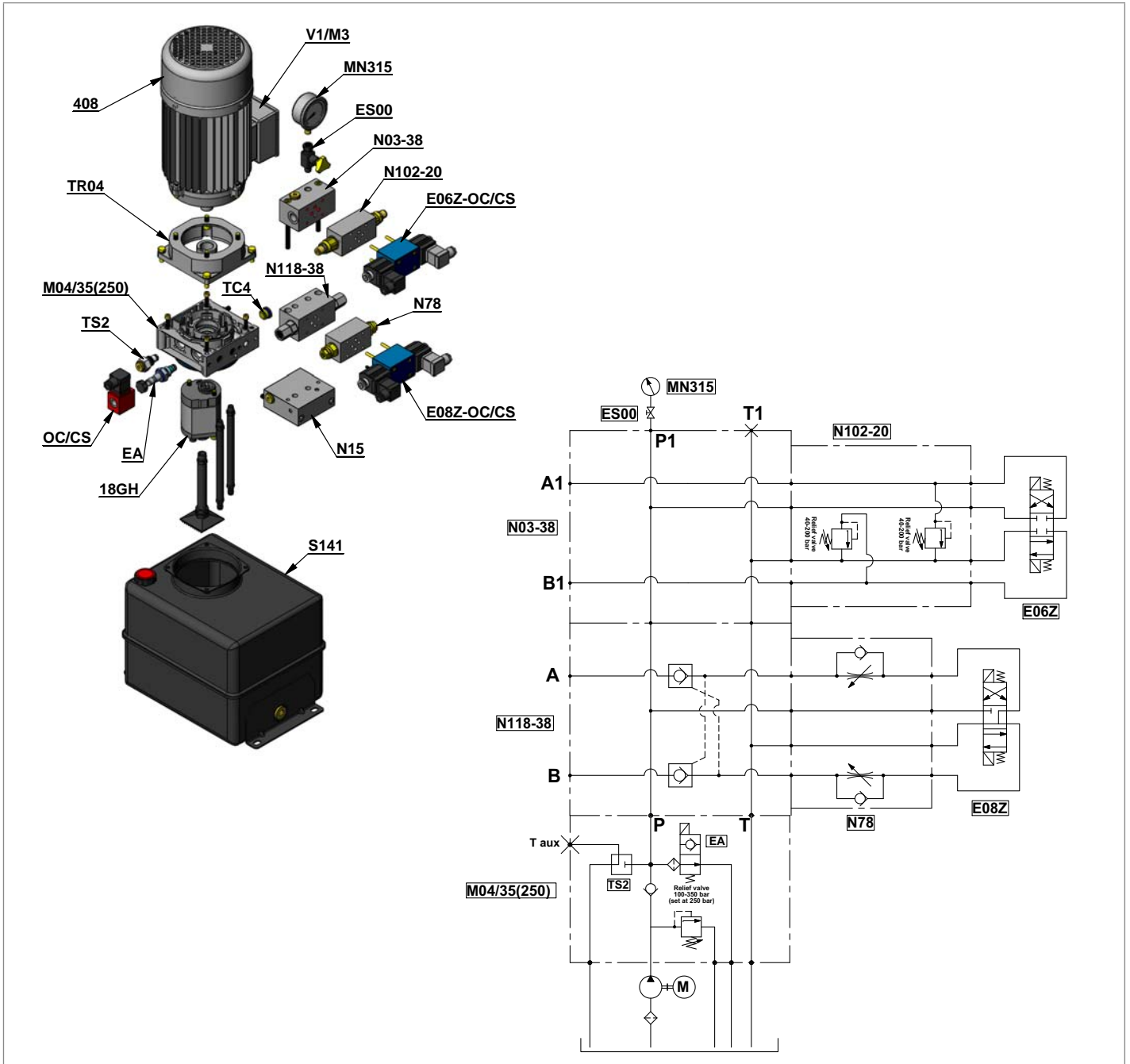

**Ordering Details for Compact Power Modules with AC Motor**

01	02	03	04	05	06	07	08	09	10	11	12
KE	2	- 408	- TR04	- M04/35 (250)	- EA/TC4/ TS2	- OC/CS	- 18GH	- S141	- V1/M3	- N15/N118-38/N78/ E08Z-OC/CS/N03-38/ N102-20/E06Z-OC/CS	- ES00/MN315
Power Module Type	Power Module Type of Motor	AC Electric motor	Junction Element	Central Manifold with Pressure range Relief Valve + Request Setting of the Relief Valve in Bar beetwen bracket	Built-in Valves in cavity n° 03-05-06	Coil Model and Connector	Gears pump	Oil Tank	Mounting Position and Mounting Brackets	Modular Stackable Elements Coil Voltage Connector	Accessories

## Ordering Details for Compact Power Modules ME with D.C. Motor

01	02	03	04	05	06	07	08	09	10	11	12	13	14

<b>Family</b>													
01	Power module type												KE K KS

<b>Power module type of motor</b>													
02	With DC motor												1

<b>D.C. Electric motor</b>													
03	In the Power Module KE-KS type is possible to assemble every code of DC motor shown in the catalogue. In the Power Module K type is not possible to assemble DC motors without front flange. (See pag.16-30)												

<b>Relay</b>													
04	The available relays are shown in the page after the selected DC motor.												

<b>Plastic Protection</b>													
05	The possibility to assemble the plastic protection is shown in the page after the selected DC motor.												

<b>Junction Elements</b>													
06	The code of the Junction Element is showing in the page after the selected DC motor.												

<b>Central Manifold with Pressure range Relief Valve + Request Setting of the Relief Valve in Bar</b>													
07	Select the required Central manifold with the required pressure range of the Relief valve and put the required setting in bar between bracket.												

<b>Built-in Valves</b>													
08	Insert the codes of the required valves following the number of the cavity in the Central Manifold. (see page after the selected Central Manifold)												

<b>Coil Model and Connector</b>													
09	In case of selection of Solenoid Built-in Valve choice the required coil Voltage and the required Connector. (See page 72-73)												

<b>Gears pump</b>													
10	Is possible to select the required pump between Standard Version and Cast iron cover version. (See page 80)												

<b>Oil Tank</b>													
11	Select the required Oil Tank. (See pag.82-92)												

<b>Mounting Position and Mounting Brackets</b>													
12	Select the required working position of the Power Module and the position of Relay and Oil Filler cap in case of mounting position V1. If needed select the Mounting Bracket. (See pag.93-94)												

<b>Modular Stackable Elements</b>													
13	If needed select the additional Modular Stackable Elements												

<b>Accessories</b>													
14	If needed select the additional Accessories												

**Example of Ordering Details for Compact Power Modules ME with D.C. Motor**

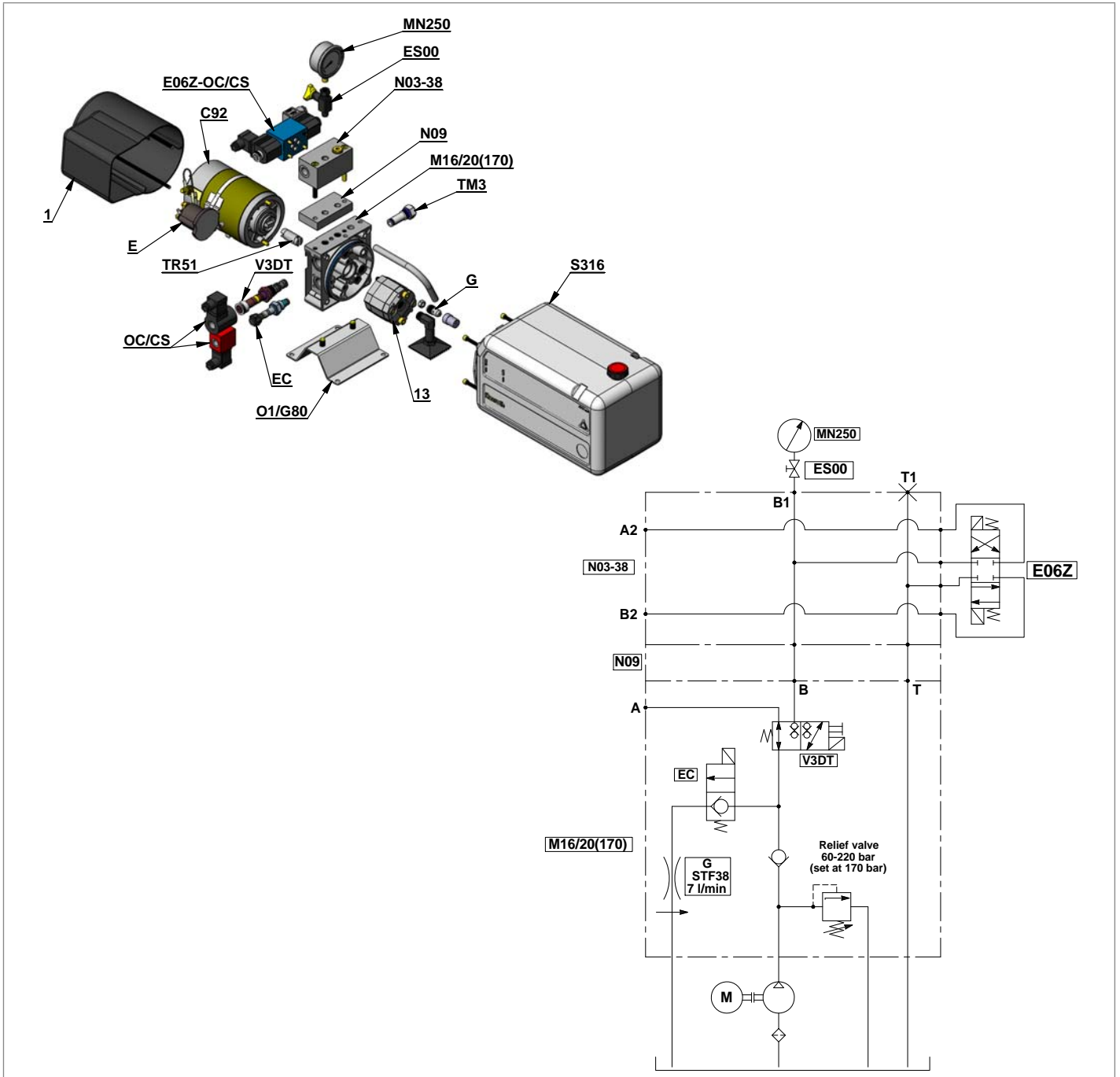

**Ordering Details for Compact Power Modules with AC Motor**

	01	02	03	04	05	06	07	08	09	10	11	12	13	14											
<b>KE</b>	<b>1</b>	-	<b>C92</b>	-	<b>E</b>	-	<b>1</b>	-	<b>TR51</b>	-	<b>M16/20(170)</b>	-	<b>V3DT/TM3/EC/G</b>	-	<b>OC/CS</b>	-	<b>13</b>	-	<b>S316</b>	-	<b>O1/G80</b>	-	<b>N09/N03-38/E06Z-OC/CS</b>	-	<b>ES00/MN250</b>
Power Module Type	Power Module Type of Motor	DC Electric motor	Relay	Plastic Protection	Junction Element	Central Manifold with Pressure range Relief Valve + Request Setting of the Relief Valve in Bar beetwen bracket	Built-in Valves in cavity n° 03-05-06	Coil Model and Connector	Gears pump	Oil Tank	Mounting Position and Mounting Brackets	Modular Stackable Elements	Accessories												

## General Technical Data for Compact Power Module KE-K and KS series

Through the years DCOC has developed a highly evolved modular system resulting in powerful, flexible and cost effective power pack range, identified as “**compact power modules**”. In its easier configuration, a “compact power module” is an assembly of electric motor, central manifold with valves, pump, oil tank and a few connection elements. The central manifold, with its built-in valves, allows to achieve a large variety of hydraulic control circuits. If more complex circuits are needed, modular integrated blocks can be added by flange mounting, or interfacing, to the central manifold to extend its capabilities.

### Typical applications

Passenger lift  
Fork lift  
Car and motorcycle lift  
Lift table  
Dumper  
Tail gate  
Scissor lift  
Gangway and davits for boats  
Material handling  
Foods machinery

### Power module selection

Choose the circuit which meets your application requirements.

Take note of all dimensions resulting from the basic components chosen for your application.

#### Note

dimensions may vary slightly and should be confirmed by DCOC, if the assembly is to be installed in a space with narrow clearance.

The tank capacity and the tank dimensions need to be large enough to assure proper pump suction: there must always be a reserve of oil in the tank when all cylinders are fully extended and avoid overflow when cylinders are fully retracted.

The tank must be evaluated also for best separation of air from oil, and for settling down oil contamination. It should be placed in a space with, at least, natural ventilation and it should permit enough heat dissipation to prevent high fluid temperature.

Select the electric motor by evaluating the power needed and the motor compliance with the heat developed during the expected run time (or “duty cycle”).

### Hydraulic fluid for compact power module

Mineral oil based hydraulic fluids suitable for hydraulic systems can be used; they should have physical lubricating and chemical properties as specified by:

MINERAL OIL BASED HYDRAULIC FLUIDS HL  
(DIN 51524 part 1)

MINERAL OIL BASED HYDRAULIC FLUIDS HL P  
(DIN 51524 part 2)

For use of environmentally friendly fluids please consult DCOC.

### Fluid viscosity, temperature range of the operating fluid, ambient temperature

The fluid viscosity should remain within the range 10 to 300 cSt (centistokes); recommended 15 to 120 cSt.

Permissive cold start viscosity is maximum 2000 cSt.

The fluid temperature should remain within the range -15°C and 80°C (5°F and 176°F).

#### Note

For compact power module with plastic tank the fluid temperature should remain within the range -15°C and 70°C (5°F and 158°F).

Ambient temperature -15°C +40°C (5°F and 104°F).

### Fluid cleanliness requirements and maintenance

We recommend a cleanliness of the operating fluid according to ISO 4406 Class 20/18/15 or cleaner. All components of the hydraulic circuit, including hoses and actuators, must be flushed and cleaned before assembling, because the compact power module has a suction filter only.

The hydraulic fluid should be replaced after the first 50 hours, and then every 1000 hours, or, at least, once a year.

### Power module installation

The mounting position (is basically un-restricted; just avoid installations that could compromise the pump suction, it is recommended to support the power module on vibration dampening blocks when the mounting structure is expected to vibrate.

### Wiring and starting-up

The wiring between battery and electric motor should be selected in order to avoid excessive voltage drop (recommended less than 1 V).

**It is strictly forbidden** to allow the backwards rotation of the pump even at the first starting: to prevent reverse

rotation, the wiring polarities must be correctly connected (except for the reversible pumps).

**Caution:** when energized, the surface temperature of the electric motor could reach temperature levels of 60-80°C (140-176°F): care should be taken to avoid any accidental contact of people with the motor surface.

### A.C. motors

The tolerances on the nominal voltage are:

Single phase motor: 230V +/-5% -

Three phase motor: 230-400V +/-10%.

Protection degree : IP54 (protection against dust and water splash).

Insulation class: F (155°C) (311°F).

All motors are aluminum alloy die cast without painting.

#### Note

Standard Single phase motors have a permanently connected run capacitor. If the motor starts with pressure in the circuit (load in the actuator) we suggest the use of specials dedicated manifolds KE series with integrated Start-Up valve (Manifold code M09 and M19).

### D.C. Motors

DCOC has a wide range of D.C. motors. In the following pages you will find a selection of our standard range.

For further information about our complete range please contact our Sales department.

All the motors shown have clockwise rotation suitable for driving our counter clockwise gear pumps.

For each motor a diagram is shown that enables the customer to select the right pump displacement needed for the required flow and working pressure.

To be sure of selecting the best electric motor for the application, also the duty cycle has to be verified.

Following are the definitions of the type of duty cycles:

S2 = Short time duty cycle: indicate the number of minutes the motor can operate before reaching the maximum allowable temperature. After this time the motor must cool down until the ambient temperature is reached.

S3 = Intermittent duty cycle: indicate the maximum time percentage (%) based on 10 minute period within the motor can run until reaching the maximum allowable temperature. For example an S3 value of 15% = 1,5 minutes running time every 10 minutes period. For 8,5 minutes the motor is switched-off.

The S2 and S3 values are related to the current draw. On the label of motor are indicated the S2 and S3 values referred to the nominal power of the motor.

To check the S2 or S3 value at different conditions is necessary to find the value of current in the motor-pumps

diagram and related it with the represented list.

All the diagrams motor-pumps are obtained at the nominal voltage of 12 or 24 Volt using fluid ISO VG 46 at 20-30°C (68-86°F).

### Central manifolds

All the Central Manifolds shown in the catalogue are made in die cast aluminium alloy except the manifold code 10 for CPM MR series that is made by extruded bar. The validation of the Central Manifolds follows a life-test with 250 bar (625 psi) pulsed pressure repeated for 300.000 cycles.

### Built-in valves

A wide range of cartridge valves and special plugs is available to be assembled in our Central Manifolds. The cartridge valves shown are designed for use in our Compact Power Module and are manufactured using steel with high mechanical strength. Surface treatments protect the exposed parts to the external environment. Standard seals are NBR (BUNA-N) with backup rings in PTFE. The cartridge valves with "leak proof seat design" have an average leakage of 10-15 drops/minute (< 1 cm<sup>3</sup>/minute 0.06 in<sup>3</sup>/min.) at the maximum pressure using fluid ISO VG46 at 40°C (104°F). The validation of the cartridge valves follows a life-test at pulsed maximum pressure (indicated for each valve) repeated for 500.000 cycles.

All the solenoid cartridge valves are fitted with protective O-Rings installed between the pole tube and the coil. These O-Rings protect the internal parts from condensation and contaminants, which could cause malfunction.

All the solenoid cartridge valves except the 2/2 VE1 series are designed for operating in D.C..

Power supply in A.C. requires a connector with bridge rectifier included. All the data in the solenoid cartridge valves data sheet are obtained with stabilized coil operating temperature and voltage at -10% of the nominal value.

### External gear pumps

DCOC offers a wide range of External Gear Pumps to cover different kinds of applications. The standard versions are suitable for the biggest part of applications. For applications requiring higher peaks of pressure (for example Fork Lift and Presses) a version with cast iron covers is available. For applications requiring high numbers of Start&Stop or low noise feature the tapered shaft version for elastic coupling is preferred (available only for central manifold K series with A.C. motors). All the pumps are pressure compensated to guarantee the best efficiency.

### Oil tanks

In this catalogue you will find a wide selection of steel and plastic tanks available as a standard product. If a special tank is required please contact our Sales Department. Steel tanks have Black paint finish and are suitable for operating temperature range -15°C / +80°C (5°F / 176°F). Plastic tanks are obtained in one piece in order to avoid welded parts that are weak points at extreme temperature and vibrations. Plastic tanks are suitable for operating temperature range -15°C / +70°C (5°F / 158°F).

#### Note

even if the plastic tank mounting system is designed to avoid oil leakage the tank must be securely anchored when fitted in mobile equipment and when subject to shocks and heavy vibrations. Please check that the anchorages do not stress or deform the tank.

### Modular stackable elements

Our modular system offers a wide range of standardised elements. They are divided in two main series:  
 Modular Elements “N” series: Modular blocks for different mounting position with mechanical valve or interface for CETOP valves to create parallel or series circuits.  
 Modular Elements “V” series: Modular blocks that incorporate solenoid operated cartridge valves 2,3,4 way. All the Modular Elements are made in extruded aluminum alloy AL 2011 (AlCu5.5Pb0.4Bi0.4 UNI 9002/5). In the catalogue you will find a selection of the main used models.

#### Note

To reduce the complexity of the system and optimize the available space, special Modular Elements can be designed and manufactured following the customers needs. In this case please contact our Sales Department.

### European machine directive 2006/42/CE

According to the Machine Directive 2006/42/CE, a complete power module, as described in paragraph 15 and made available to the European market, enters into the definition of “partly completed machinery”.

Instead, the power module sub-assemblies (motor, pump, reservoir, central manifold,...), when not assembled into a complete power pack, are considered “components” which can be employed in a “machinery” or a “partly completed machinery”. In this case, the DCOC components and sub-assemblies must be fitted in compliance with all the relevant technical data sheet applicable to the product, and shall not be operated, adjusted or disassembled before the complete machinery where they are incorporated has been

declared to be in compliance with the Machine Directive 2006/42/CE.

#### Note

All the components shown in the catalogue ARE NOT suitable for use in potentially explosive atmosphere.

### Technical information

Below you will find the most common equations used in hydraulics:

	Common Units	Symbols	Equations
<b>Flow</b>	l/min	Q	$Q = \frac{D \times n}{1000} \times 0,95$
<b>Operating pressure</b>	bar	P	$P = \frac{F}{0,1 \times A}$
<b>Internal diameter hydraulic cylinder</b>	mm	d	–
<b>Area of hydraulic cylinder</b>	mm <sup>2</sup>	A	$A = \frac{\pi \times d^2}{4}$
<b>Piston force</b>	N	F	–
<b>Drive shaft</b>	rev/min	n	–
<b>Power requirement for motor</b>	kW	N	$N = \frac{P \times Q}{612}$
<b>Pump displacement</b>	cm <sup>3</sup> /rev	D	–
<b>Torque requirement</b>	Nm	M	$M = \frac{D \times P}{62,8 \times 0,87}$



## Compact Power Module Type

### Standard Type KE series

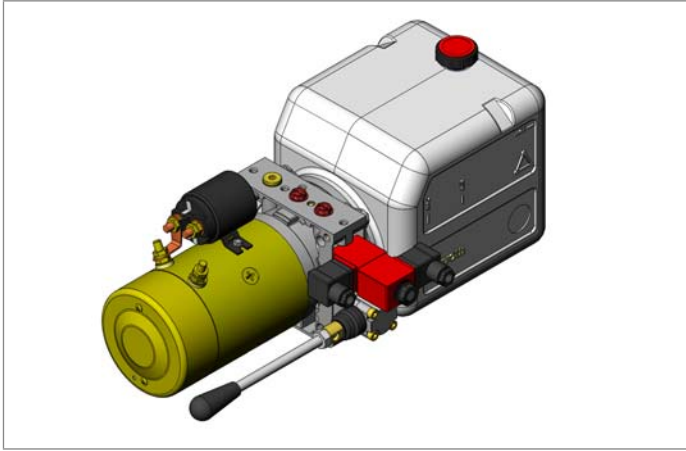

#### Complex circuits, direct flange AC motors.

DC motors up to 3000 W.

AC motors up to 4000 W (5,5 hp).

Pump displacement up to 7,9 cm<sup>3</sup> (0,31 inch<sup>3</sup>).

Pressure up to 300 bar (4350 psi).

Optionals:

Start-up valve inside.

3-ways solenoid operated valve inside.

4-ways solenoid operated valve inside.

AC electric motor with direct coupling for smaller dimensions.

### Optional Type K series

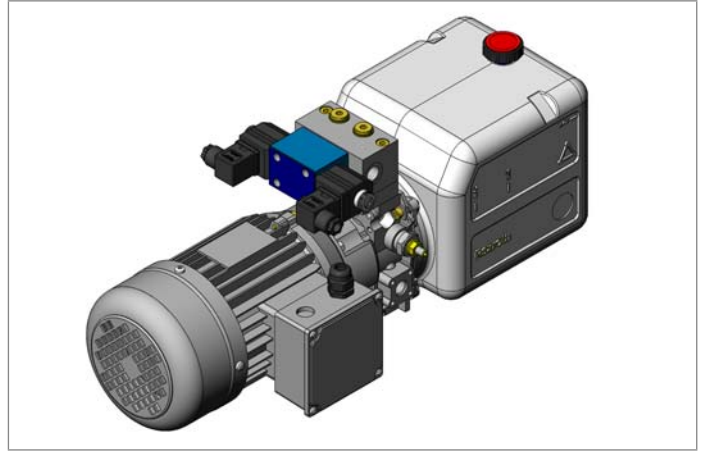

#### Standardized central manifold for simple hydraulics circuits.

DC motors up to 3000 W.

AC motors up to 4000 W (5,5 hp).

Pump displacement up to 7,9 cm<sup>3</sup> (0,31 inch<sup>3</sup>).

Pressure up to 300 bar (4350 psi).

Optionals:

Elastic coupling.

### Optional Type KS series

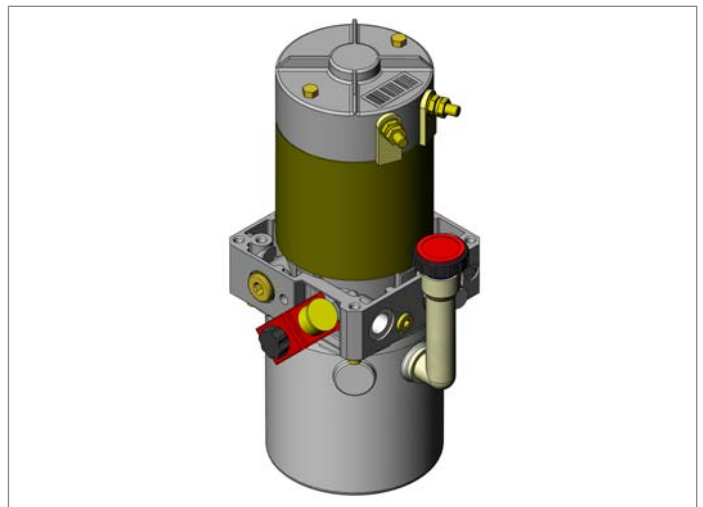

#### Designed for lifting applications.

Ready solution for simple acting circuits with the possibility of unloading valve.

DC motors up to 3000 W.

AC motors up to 4000 W (5,5 hp).

Pump displacement up to 7,9 cm<sup>3</sup> (0,31 inch<sup>3</sup>).

Pressure up to 300 bar (4350 psi).

#### Note

that every power module type can be mounted in horizontal or vertical position.

## A.C. Electric Motors Standard Flange

### Standard A.C. Motors in B14 form.

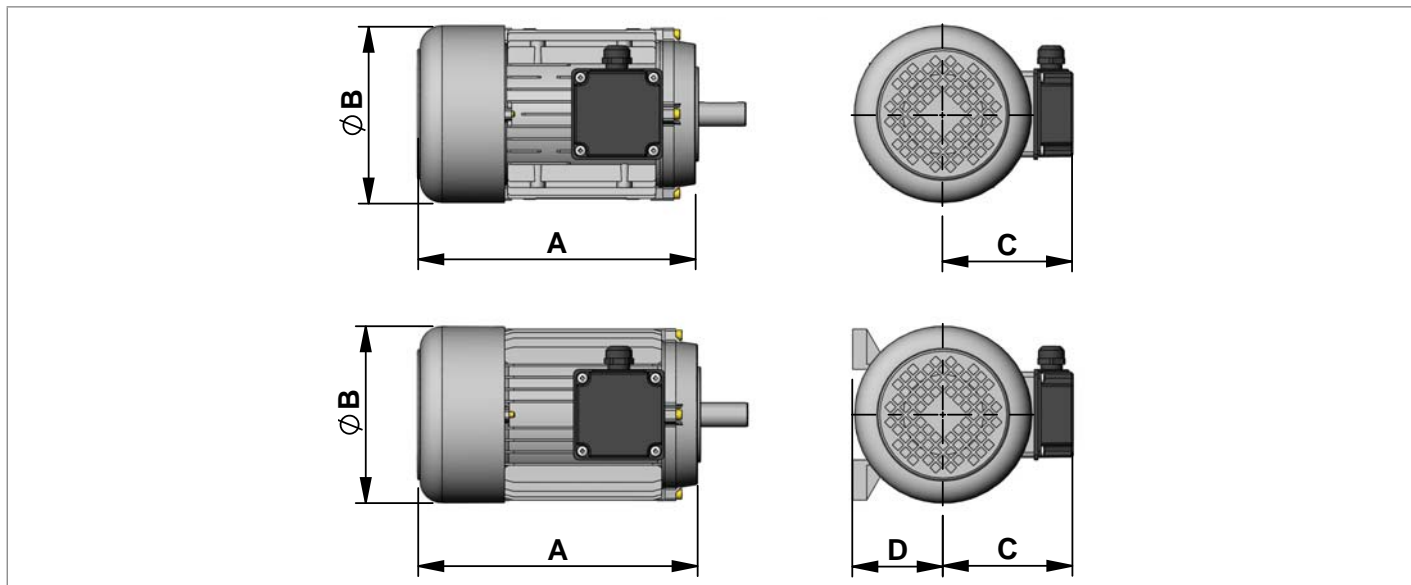

### 2 Poles Three Phase

Current Motors 230/400V 50Hz 278-/480V 60Hz IP54 (2900 rpm at 50Hz)

Code	Type	Material Number	Power (kW)	Power (hp)	Size IEC	Duty Cycle	A mm (inch)	ØB mm (inch)	C mm (inch)	D mm (inch)	Efficiency Classe
204	C162208000	R932000450	0,75	1	80	S3 60%	237 (9,33)	156 (6,14)	123 (4,84)	80 (3,15)	IE1
205	C162209000	R932000451	1,1	1,5	80	S3 60%	237 (9,33)	156 (6,14)	123 (4,84)	80 (3,15)	IE1
206	C162210000	R932000452	1,5	2	90	S3 60%	255 (10,04)	178 (7,00)	128 (5,04)	90 (3,54)	IE1
207	C162211000	R932000453	2,2	3	90	S3 60%	279 (10,99)	178 (7,00)	128 (5,04)	90 (3,54)	IE1
208	C1622S1268DR	R932008028	3	4	90	S2 60MIN.	314 (12,36)	178 (7,00)	132 (5,20)	90 (3,54)	IE1
210	C1622130DR	R932009055	4	5,5	112	S2 60MIN.	333 (13,11)	219 (8,62)	159 (6,26)	112 (4,41)	IE1

### 4 Poles Three Phase

Current Motors 230/400V 50Hz IP54 (1450 rpm at 50Hz)

Code	Type	Material Number	Power (kW)	Power (hp)	Size IEC	Duty Cycle	A mm (inch)	ØB mm (inch)	C mm (inch)	D mm (inch)	Efficiency Classe
402	C1622670DR	R932008027	0,25	0,35	71	S1	218 (8,58)	140 (5,51)	109 (4,29)	71 (2,80)	-
403	C1622680DR	R932006105	0,37	0,5	71	S1	212 (8,35)	140 (5,51)	113 (4,45)	71 (2,80)	-
404	C1622150DR	R932006106	0,55	0,75	80	S1	250 (9,84)	156 (6,14)	125 (4,92)	80 (3,15)	-
405	C1622160DR	R932006107	0,75	1	80	S2 60MIN.	250 (9,84)	156 (6,14)	125 (4,92)	80 (3,15)	IE1
406	C1622170DR	R932006108	1,1	1,5	90	S2 60MIN.	260 (10,24)	178 (7,00)	135 (5,32)	90 (3,54)	IE1
407	C1622180DR	R932006109	1,5	2	90	S2 60MIN.	282 (11,10)	178 (7,00)	135 (5,32)	90 (3,54)	IE1
408	C1622S1034DR	R932006110	2,2	3	90	S2 60MIN.	284 (11,18)	178 (7,00)	135 (5,32)	90 (3,54)	IE1
409	C1622200DR	R932006111	3	4	100	S2 60MIN.	305 (12,00)	195 (7,68)	145 (5,71)	100 (3,94)	IE1
410	C1622210DR	R932006112	4	5,5	112	S2 60MIN.	335 (13,19)	219 (8,62)	160 (6,30)	112 (4,41)	IE1

**Standard A.C. Motors in B14 form.**

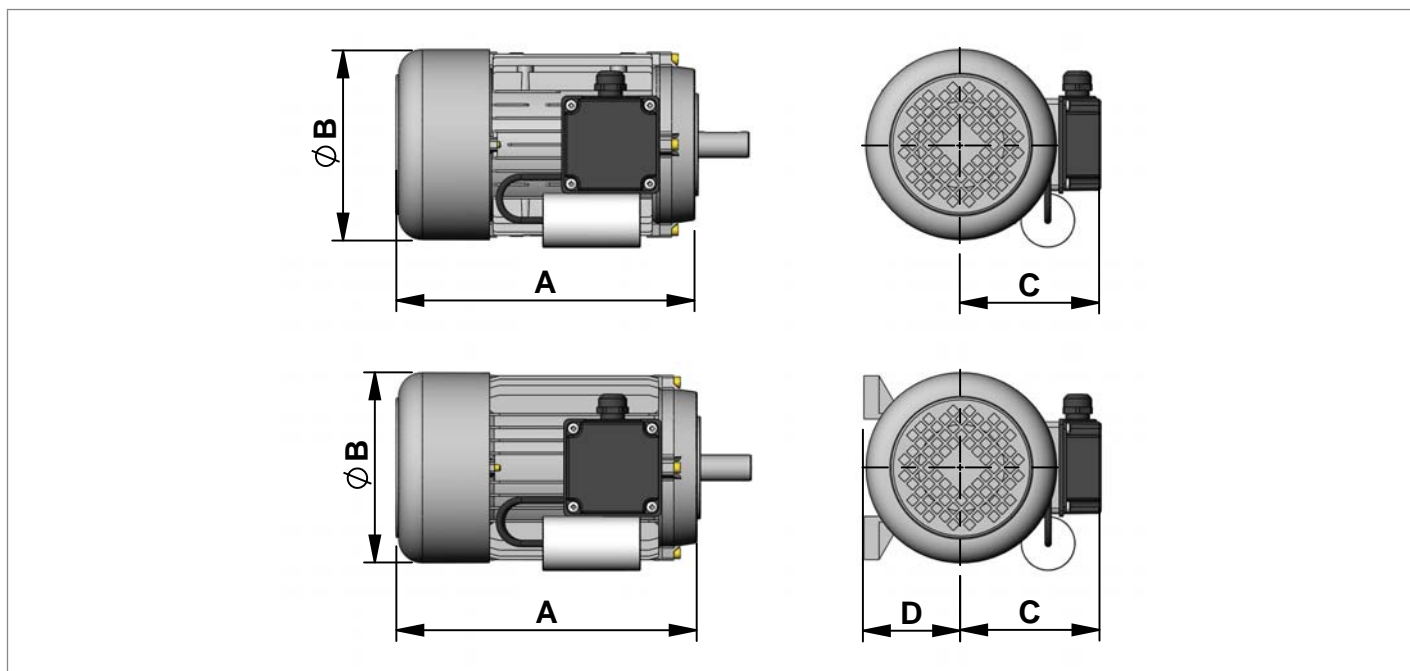

On request motors in B34 form are available. In this cases, please put “B34” after the code of the motor when filling in the description. Example “408MB34”.

**2 Poles Single Phase**

Current Motors 230V 50Hz IP54 (2900 rpm at 50Hz)

Code	Type	Material Number	Power (kW)	Power (hp)	Size IEC	Duty Cycle	A mm (inch)	ØB mm (inch)	C mm (inch)	D mm (inch)
204M	C1622S1264	R932000361	0,75	1	80	S1	237 (9,33)	156 (6,14)	123 (4,84)	80 (3,15)
205M	C1622S1342	R932000400	1,1	1,5	80	S1	237 (9,33)	156 (6,14)	123 (4,84)	80 (3,15)
206M	C1622S1181	R932000333	1,5	2	90	S1	255 (10,04)	178 (7,00)	128 (5,04)	90 (3,54)
207M	C162291000	R932000501	2,2	3	90	S1	279 (10,99)	178 (7,00)	128 (5,04)	90 (3,54)

**4 Poles Single Phase**

Current Motors 230V 50Hz Form B14 Protection IP54 (1450 rpm at 50Hz)

Code	Type	Material Number	Power (kW)	Power (hp)	Size IEC	Duty Cycle	A mm (inch)	ØB mm (inch)	C mm (inch)	D mm (inch)
402M	C162271000	R932000496	0,25	0,35	71	S1	218 (8,58)	140 (5,51)	109 (4,29)	71 (2,80)
403M	C162272000	R932000497	0,37	0,5	71	S1	212 (8,35)	140 (5,51)	113 (4,45)	71 (2,80)
404M	C162239000	R932000471	0,55	0,75	80	S1	250 (9,84)	156 (6,14)	125 (4,92)	80 (3,15)
405M	C162240000	R932000472	0,75	1	80	S1	250 (9,84)	156 (6,14)	125 (4,92)	80 (3,15)
406M	C162241000	R932000473	1,1	1,5	90	S1	260 (10,24)	178 (7,00)	135 (5,32)	90 (3,54)
407M	C162242000	R932000474	1,5	2	90	S1	282 (11,10)	178 (7,00)	135 (5,32)	90 (3,54)
408M	C162244000	R932000475	2,2	3	100	S1	309 (12,16)	195 (7,68)	145 (5,71)	100 (3,94)

**Note**

The electric motors with standard flange shown in this pages are delivered by different certified suppliers. This means the indicated dimensions could change a little, depending on which manufacturer will be assembled. On the CPM the choice of the manufacturer is based on our stock availability.

### Junction Elements for A.C. Electric Motor Standard Flange

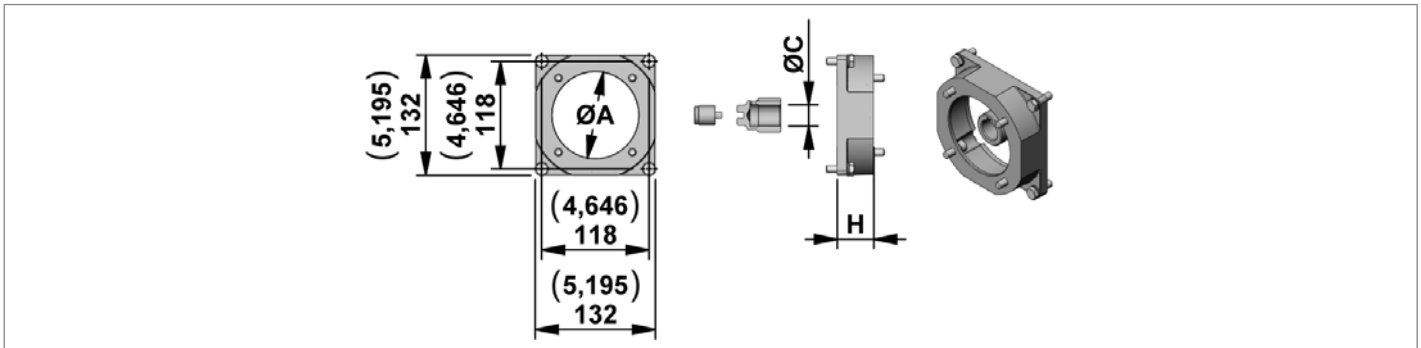

#### Junction Elements for manifolds KE and KS series (STD COUPLINGS)

Code	Motor Codes	Size IEC	A mm (inch)	C mm (inch)	H mm (inch)	Type	Material Number
TR02	402-402M 403-403M	71	70 (18,50)	14 (0,55)	20,5 (0,81)	K01KE970TR002	R932001894
TR03	204-204M-404-404M 205-205M-405-405M	80	80 (3,15)	19 (0,75)	29 (1,14)	K01KE970TR003	R932001895
TR04	206-206M-406-406M 207-207M-407-407M 208-408	90	95 (3,74)	24 (0,95)	40 (1,57)	K01KE970TR004	R932001896
TR05	409-408M 210-410	100 112	110 (4,33)	28 (1,10)	57 (2,24)	K01KE970TR005	R932001897

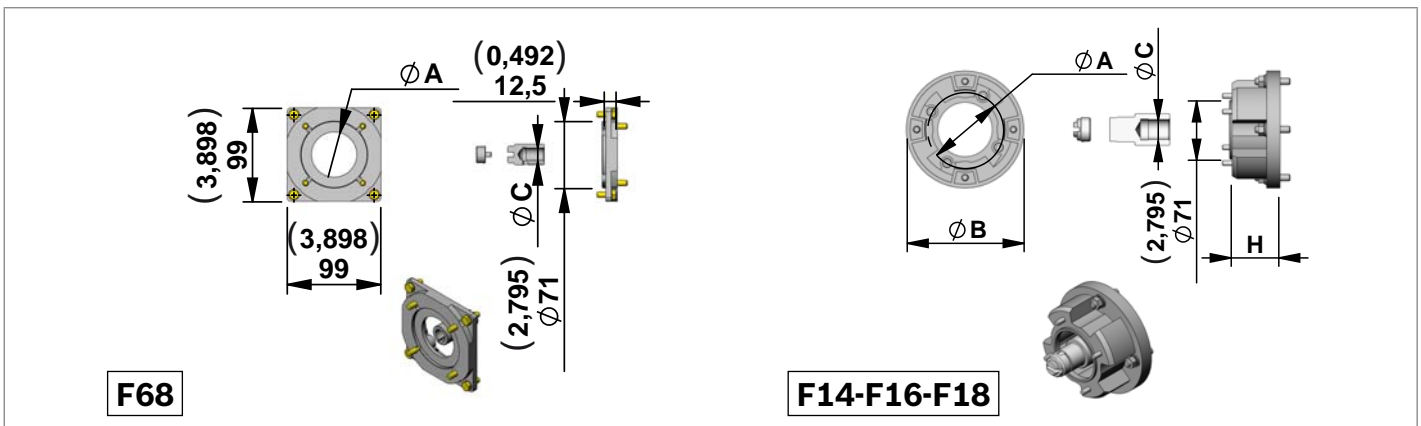

#### Junction Elements for manifolds K series (STD COUPLINGS)

Code	Motor Codes	Size IEC	A mm (inch)	B mm (inch)	C mm (inch)	H mm (inch)	Type	Material Number
F68	402-402M 403-403M	71	70 (18,50)	-	14 (0,55)	-	K01K3970TR056	R932001917
F14	204-204M-404-404M 205-205M-405-405M	80	80 (3,15)	120 (4,72)	19 (0,75)	45 (1,77)	K01K3970TR022	R932001909
F16	206-206M-406-406M 207-207M-407-407M 208-408	90	95 (3,74)	140 (5,51)	24 (0,95)	57 (2,24)	K01K3970TR021	R932001908
F18	409-408M 210-410	100 112	110 (4,33)	160 (6,30)	28 (1,10)	67 (2,64)	K01K3970TR025	R932001911

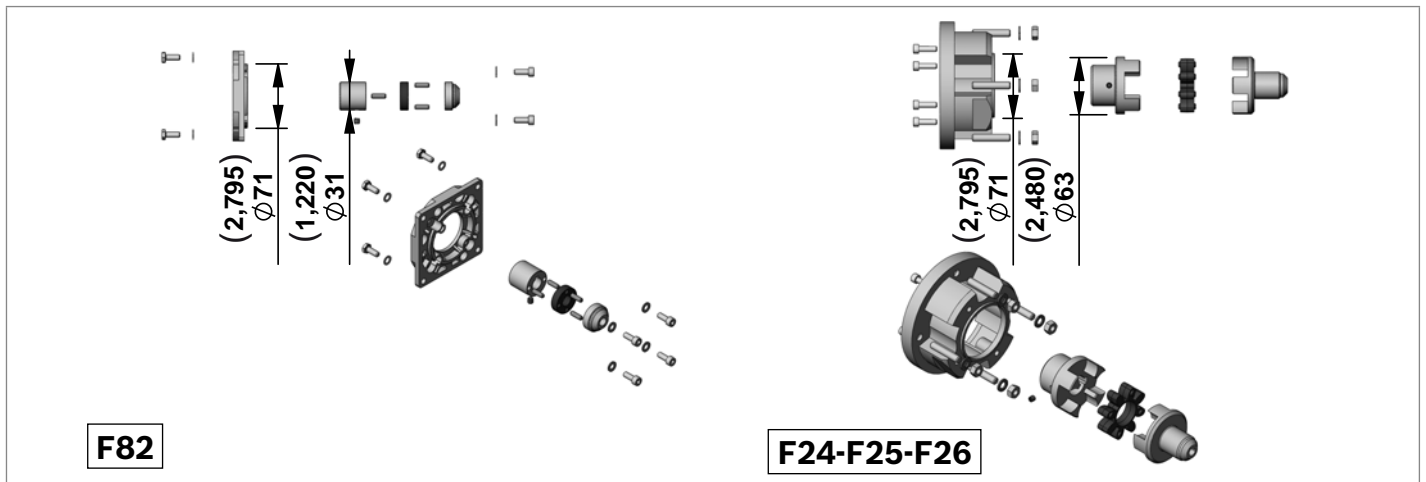

**Junction Elements for manifolds K series (ELASTIC COUPLINGS)**

Code	Motor Codes	Size IEC	Type	Material Number
<b>F82</b>	402-402M 403-403M	71	K01K3970TR083	R932001926
<b>F24</b>	204-204M-404-404M 205-205M-405-405M	80	K01K3970TR026	R932001912
<b>F25</b>	206-206M-406-406M 207-207M-407-407M 208-408	90	K01K3970TR027	R932001913
<b>F26</b>	409-408M 210-410	100 112	K01K3970TR028	R932001914

**Note**

The flanges shown in this page have the same dimensions as per the flanges used for standard couplings.  
 The elastic couplings are suggested for applications requiring low noise and applications with high frequency of START/STOP operations.

### A.C. Electric Motor Compact Mounting Style for Power Module Type KE and KS

These motors are designed to reduce the overall dimensions and the cost of the junction elements.

They can be assembled only in the manifold KE and KS series.

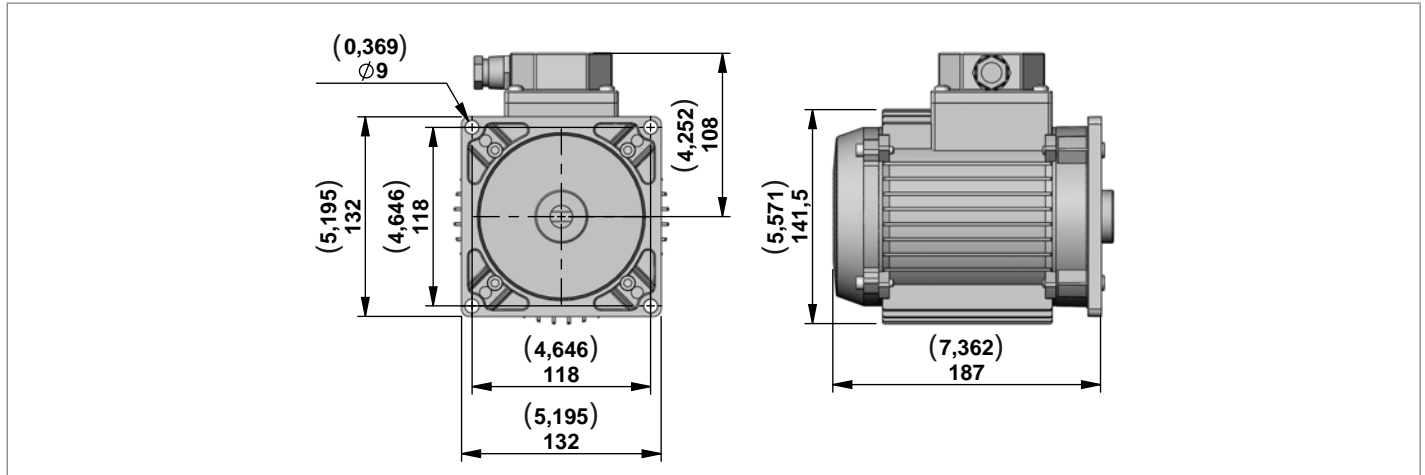

#### Three Phase Current Motors 230/400V 50Hz IP54 Size IEC 71

Code	Type	Material Number	Power (kW)	Power (hp)	Poles	Rpm at 50Hz	Duty Cycle	Thermal Switch
<b>724</b>	C1622S1085C	R932000302	0,75	1	2	2900	S3 30%	no
<b>724T</b>	C1622S1368C	R932006634	0,75	1	2	2900	S3 30%	yes
<b>725</b>	C1622S1083C	R932000301	1,1	1,5	2	2900	S3 30%	no
<b>725T</b>	C1622S1374	R932000423	1,1	1,5	2	2900	S3 30%	yes

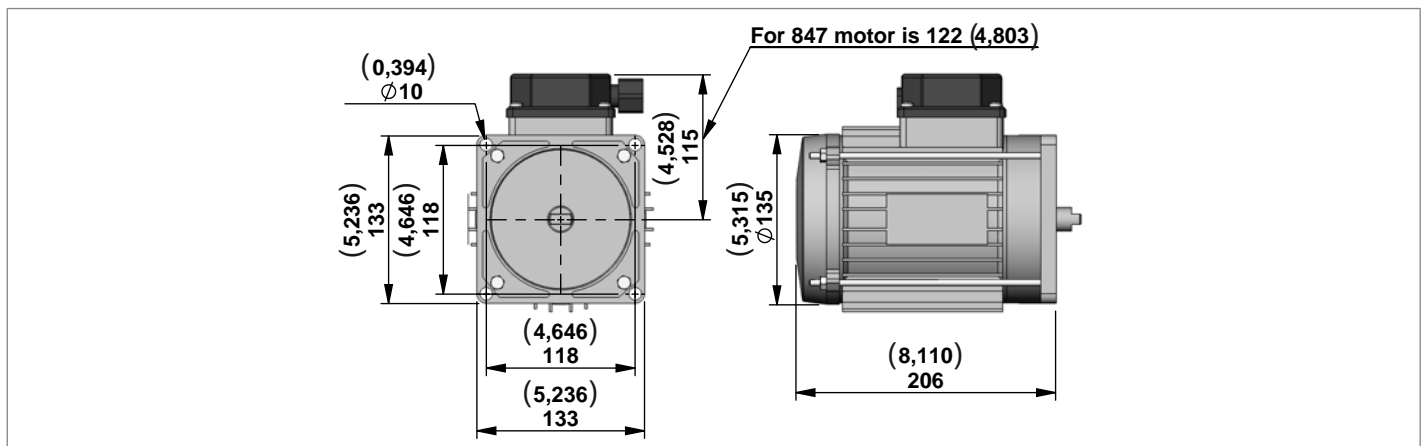

#### Three Phase Current Motors 230/400V 50Hz IP54 Size IEC 80

Code	Type	Material Number	Power (kW)	Power (hp)	Poles	Rpm at 50Hz	Duty Cycle	Thermal Switch
<b>826T</b>	C1622S1410C	R932011320	1,5	2,0	2	2800	S3 20%	yes
<b>827T</b>	C1622S1409C	R932011321	2,2	3,0	2	2800	S3 15%	yes
<b>828T</b>	C1622S1417C	R932011319	3,6	4,8	2	2800	S3 7%	yes
<b>847</b>	C1622S1288C	R930053403	1,5	2,0	4	1450	S3 20%	no

Junction Elements for A.C. Electric Motor Compact Mounting Style for Power Module Type KE and KS

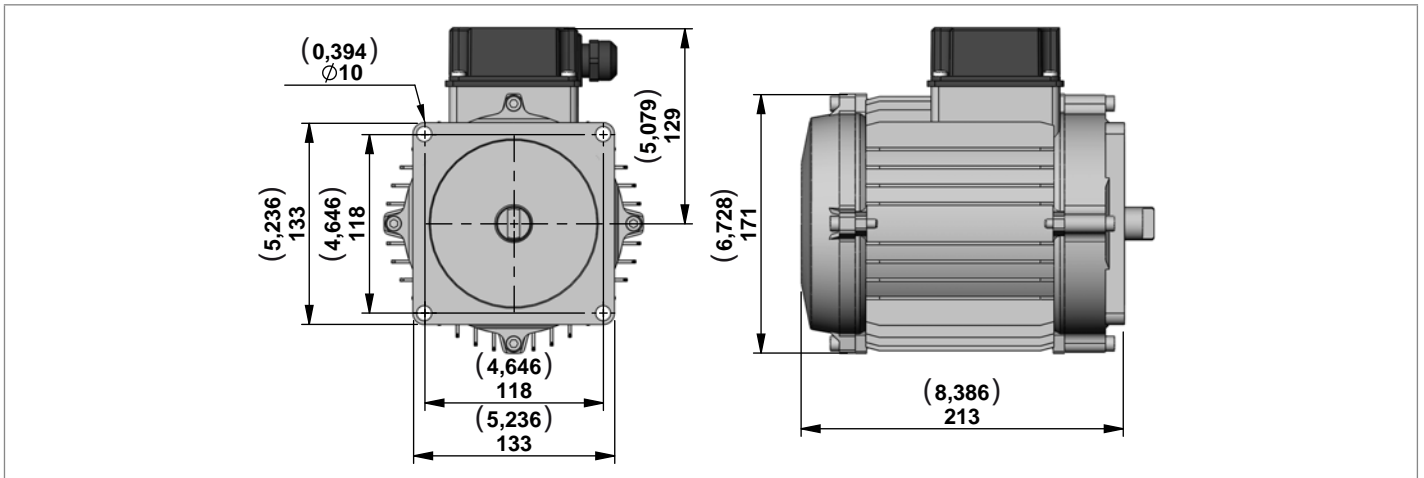

**Three Phase Current Motors 230/400V 50Hz IP54 Size IEC 90**

Code	Type	Material Number	Power (kW)	Power (hp)	Poles	Rpm at 50Hz	Duty Cycle	Thermal Switch
948T	C1622S1380	R932000429	2,2	3	4	1450	S3 30%	yes
949T	C1622S1166	R932000323	2,6	3,5	4	1450	S3 30%	yes
950T	C1622S1360	R932000412	3	4	4	1450	S3 10%	yes

**Note**

The motors shown in these tables are a selection of our range.  
 In case of needs of different technical characteristics PLEASE CONTACT OUR SALES DEPARTEMENT.  
 The electric motors with standard flange shown in this pages are delivered by different certified suppliers.  
 This means the indicated dimensions could change a little, depending on which manufacturer will be assembled.  
 On the CPM the choice of the manufacturer is based on our stock availability.

**Junction Elements for A.C. Electric Motor Compact Mounting Style for Power Module Type KE and KS**

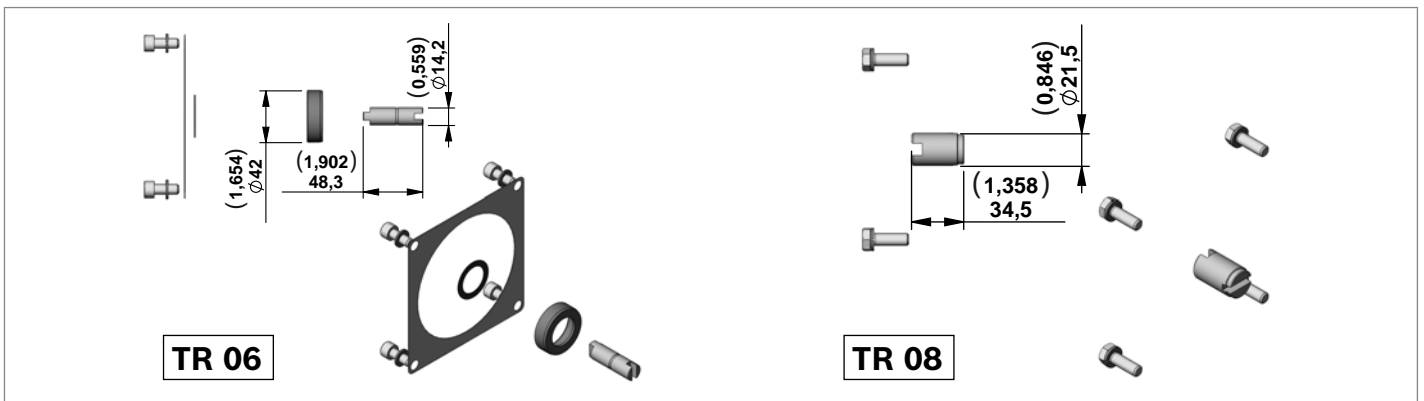

**Junction Elements for manifolds KE and KS series**

Code	Motor Codes	Size IEC	Type	Material Number
TR06	724-724T-725-725T-745	71	K01KE970TR006	R932001899
TR08	826-826T-827-827T-828-828T-847-948-948T-949-949T-950T	80	K01KE970TR008	R932001900

### D.C. Electric Motors Standard Performance

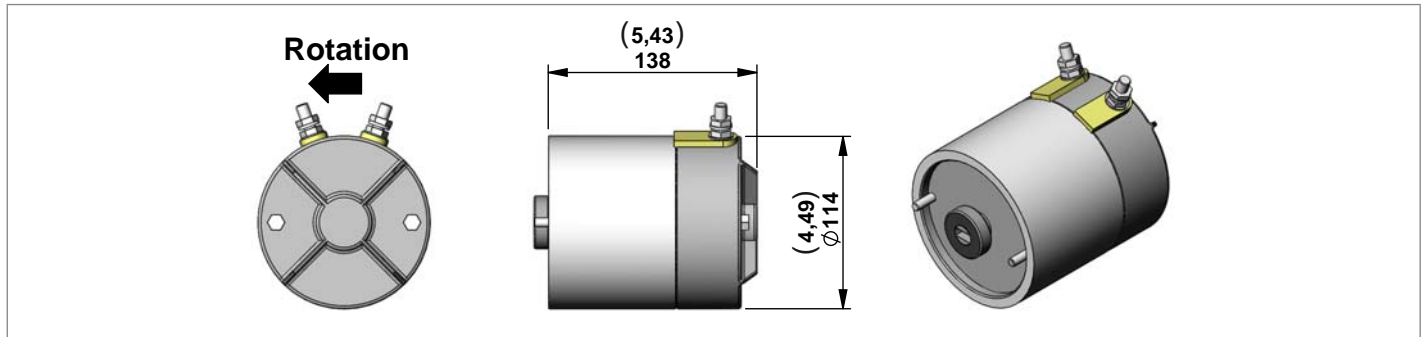

Code	Voltage (V)	Power (W)	Duty Cycle S3% S2 min.	Thermal Switch	UL Certified	Protection index	Type	Material Number
<b>C172</b>	24	1300	15% 6,5 min	NO	YES	IP 54	C1620S1072	R932009389

#### Electric Motor C172 (24V – 1300W) Diagrams

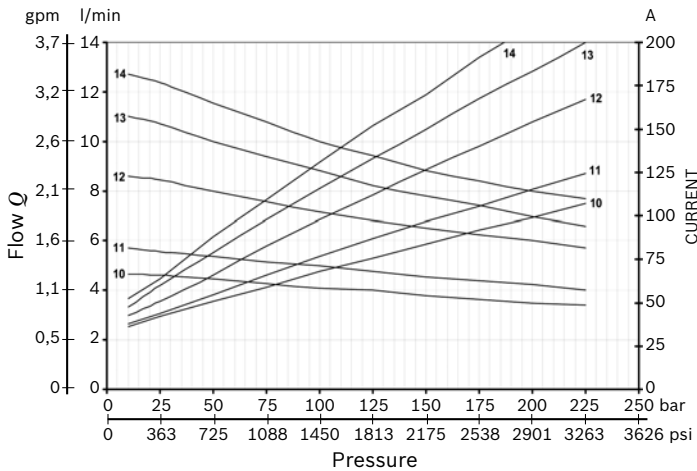

#### S2 - S3 performance

Amps	S2 (min.)	S3(%) (10 min.)
<b>75</b>	6	17%
<b>100</b>	4	11%
<b>125</b>	2,4	7,5%
<b>150</b>	1,5	5%
<b>175</b>	1	3,5%

#### Note

The values of the curves may change slightly depending on the brand / model of pump that is mounted.



### Relay

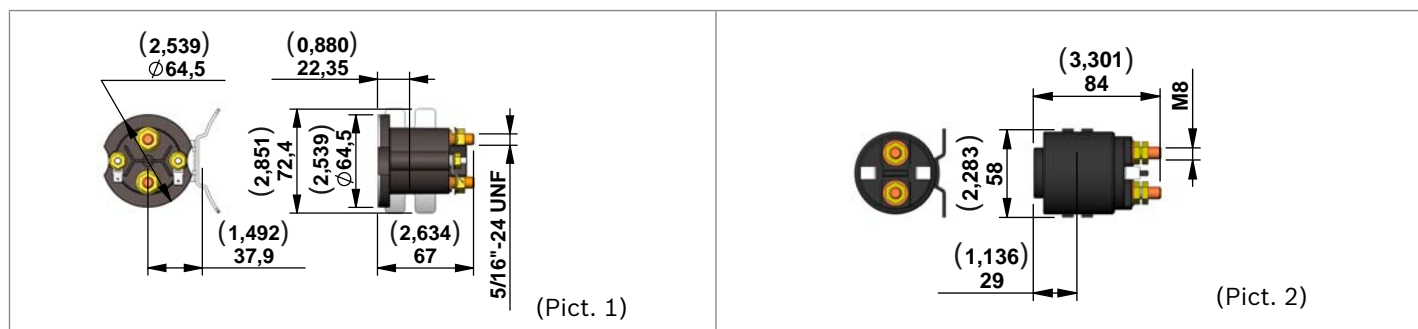

Starting Relay **Standard Performance** (Pict. 1)

Code	Voltage (V)	Nominal Current (A)	Short time Current (A)	Protection INDEX	UL Certified	Type	Material Number
<b>A</b>	Without Relay						
<b>H</b>	24	150	350	IP66	NO	C165535000	R932000693
<b>L</b>	24	150	350	IP66	YES	C165540000	R932008749

Starting Relay **High Performance** (silver plate contact) (Pict. 2)

Code	Voltage (V)	Nominal Current (A)	Short time Current (A)	Protection INDEX	UL Certified	Type	Material Number
<b>A</b>	Without Relay						
<b>E</b>	24	150	350	IP54	NO	C165525000	R932000691

### Kit Motor + Relay



Motor + Relay	Type	Material Number
<b>C172+relay 24V STANDARD performance</b>	K396824172PSF	R930051612
<b>C172+relay 24V STANDARD performance UL certified</b>	K396824172PSFUL	R930051614
<b>C172+relay 24V HIGH performance</b>	K396824172EF	R930051617

### Junction Elements for D.C. Electric STD motor flange

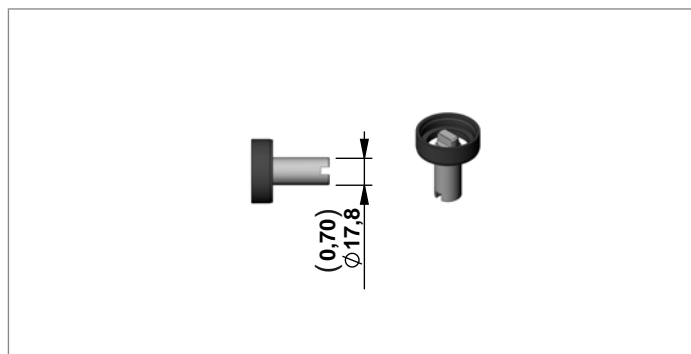

### Junction Elements for manifolds **KE** and **KS** series

Code	Type	Material Number
<b>TR65</b>	K01KE970TR065	R932001905

**Note**  
Suitable for KE and KS only.

### D.C. Electric Motors Standard Performance

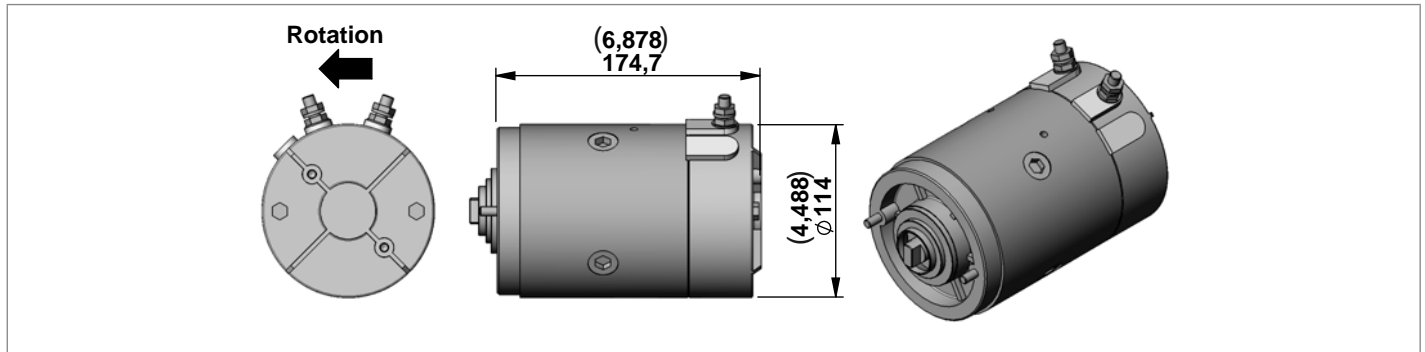

Code	Voltage (V)	Power (W)	Duty Cycle S3% S2 min.	Thermal Switch	UL Certified	Protection index	Type	Material Number
<b>C190</b>	12	1600	5% 2 min	no	yes	IP 54	C1620S1090	R930056392
<b>C191</b>	12	1600	5% 2 min	yes	yes	IP 54	C1620S1091	R930056391
<b>C192</b>	24	2200	5% 2 min	no	yes	IP 54	C1620S1092	R930056390
<b>C193</b>	24	2200	5% 2 min	yes	yes	IP 54	C1620S1093	R930056389

**Electric Motor C190-191 (12V – 1600W) Diagrams**

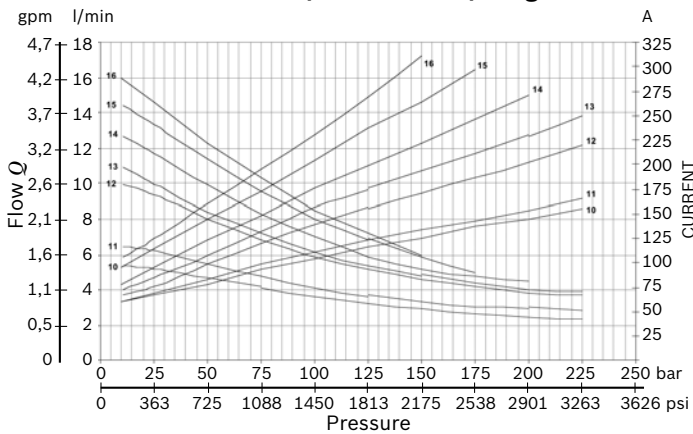

**Electric Motor C192 - C193 (24V – 2200W) Diagrams**

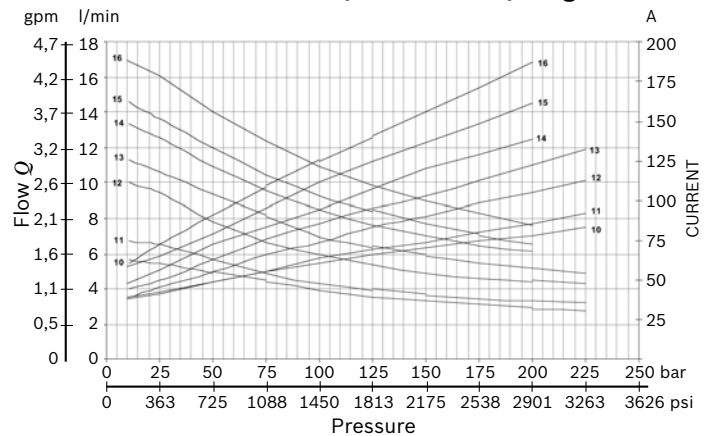

**S2 - S3 performance**

Amps	S2 (min.)	S3(%) (10 min.)
<b>150</b>	5,5	12%
<b>200</b>	3,5	8%
<b>250</b>	2	6%
<b>300</b>	1,5	4%
<b>350</b>	1	3%

**S2 - S3 performance**

Amps	S2 (min.)	S3(%) (10 min.)
<b>75</b>	5	12%
<b>100</b>	3	7%
<b>125</b>	1,8	5%
<b>150</b>	1	4%
<b>175</b>	0,7	2,5%

**Note**

The values of the curves may change slightly depending on the brand / model of pump that is mounted.

### Relay

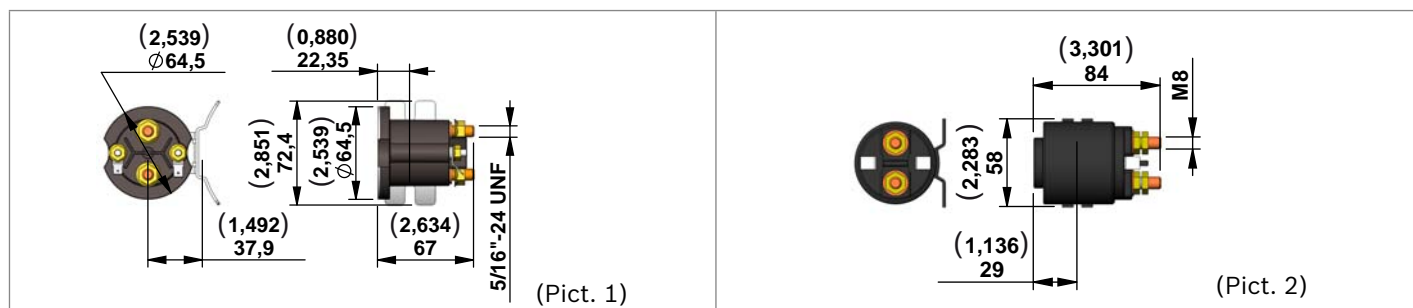

Starting Relay **Standard Performance** (Pict. 1)

Code	Voltage (V)	Nominal Current (A)	Short time Current (A)	Protection INDEX	UL Certified	Type	Material Number
A	Without Relay						
G	24	150	350	IP66	NO	C165534000	R932000692
H	24	150	350	IP66	NO	C165535000	R932000693
L	24	150	350	IP66	YES	C165540000	R932008749

Starting Relay **High Performance** (silver plate contact) (Pict. 2)

Code	Voltage (V)	Nominal Current (A)	Short time Current (A)	Protection INDEX	UL Certified	Type	Material Number
A	Without Relay						
C	24	150	350	IP54	NO	C165524000	R932000690
E	24	150	350	IP54	NO	C165525000	R932000691

### Kit Motor + Relay



Motor + Relay	Type	Material Number
<b>C190+relay 12V STANDARD performance</b>	K396812190PSCUF	R930034093
<b>C190+relay 12V HIGH performance</b>	K396812190C	R930034094
<b>C191+relay 12V STANDARD performance</b>	K396812191PSCUF	R930034095
<b>C191+relay 12V HIGH performance</b>	K396812191C	R930034097
<b>C192+relay 24V STANDARD performance</b>	K396824192PSCUF	R930035261
<b>C192+relay 24V STANDARD performance UL certified</b>	K396824192PSUL	R930034098
<b>C192+relay 24V HIGH performance</b>	K396824192E	R930034101
<b>C193+relay 24V STANDARD performance</b>	K396824193PSCUF	R930034102
<b>C193+relay 24V STANDARD performance UL certified</b>	K396824193PSUL	R930035112
<b>C193+relay 24V HIGH performance</b>	K396824193E	R930035252

### Plastic Protection

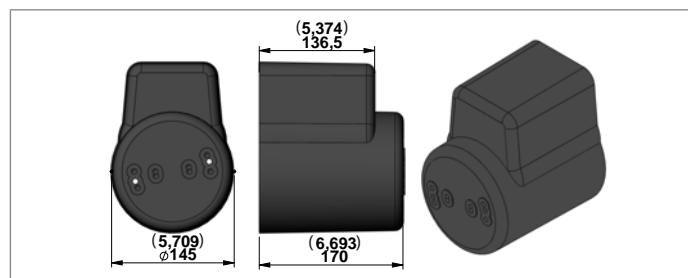

Code	Type	Material Number
0	Without Protection -	-
1	With Protection	K229701000 R932002246

Kit for assembly plastic protection

Type	Material Number
K01K211565000	R930059147

### Junction Elements for D.C. Electric Motor

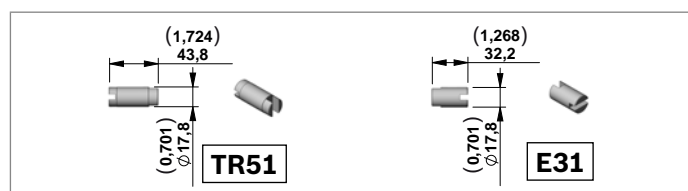

Junction Elements for manifolds

Code	Series	Type	Material Number
TR51	KE - KS	K01KE970TR051	R932001901
E31	K	K01K3970TR008	R932001907

### D.C. Electric Motors High Performance

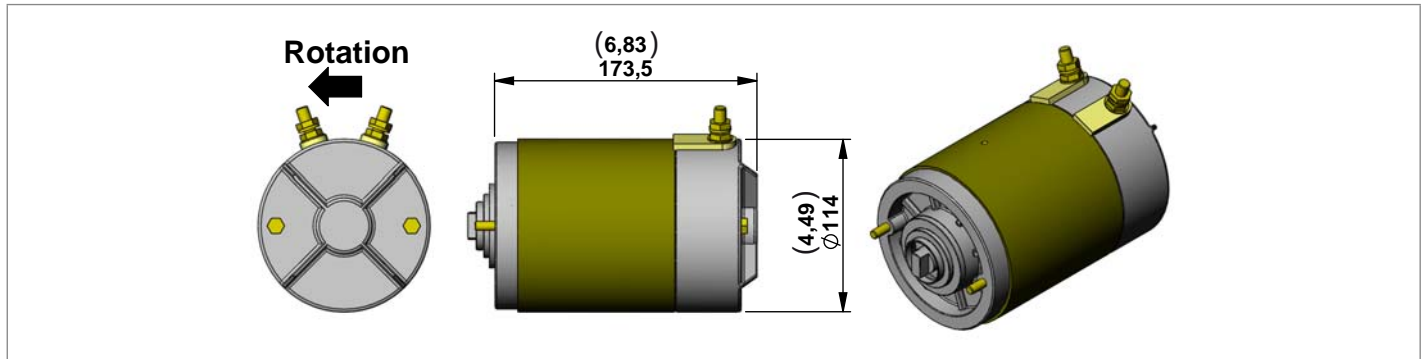

Code	Voltage (V)	Power (W)	Duty Cycle S3% S2 min.	Thermal Switch	UL Certified	Protection index	Type	Material Number
<b>C91</b>	12	1600	7,5% 3 min	NO	NO	IP 54	C162090000	R932000272
<b>C102</b>	12	1600	7,5% 3 min	YES	NO	IP 54	C1620S1002	R932000201
<b>C92</b>	24	2200	4,5% 1,2 min	NO	NO	IP 54	C162091000	R932000273
<b>C103</b>	24	2200	4,5% 1,2 min	YES	NO	IP 54	C1620S1003	R932000202

**Electric Motor C91-C102 (12V – 1600W) Diagrams**

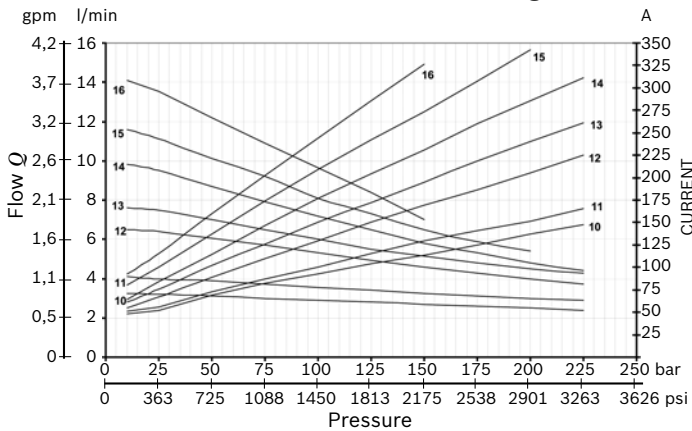

**Electric Motor C92-C103 (24V – 2200W) Diagrams**

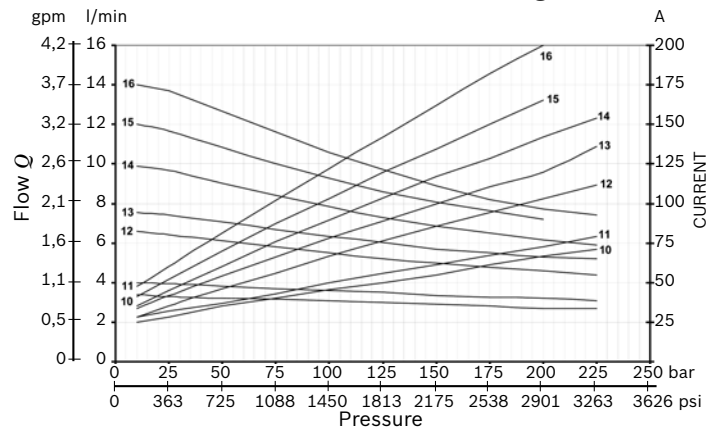

**S2 - S3 performance**

Amps	S2 (min.)	S3(%) (10 min.)
<b>150</b>	5,5	12%
<b>200</b>	3,5	8%
<b>250</b>	2	6%
<b>300</b>	1,5	4%
<b>350</b>	1	3%

**S2 - S3 performance**

Amps	S2 (min.)	S3(%) (10 min.)
<b>75</b>	5	12%
<b>100</b>	3	7%
<b>125</b>	1,8	5%
<b>150</b>	1	4%
<b>175</b>	0,7	2,5%

**Note**

The values of the curves may change slightly depending on the brand / model of pump that is mounted.

### Relay

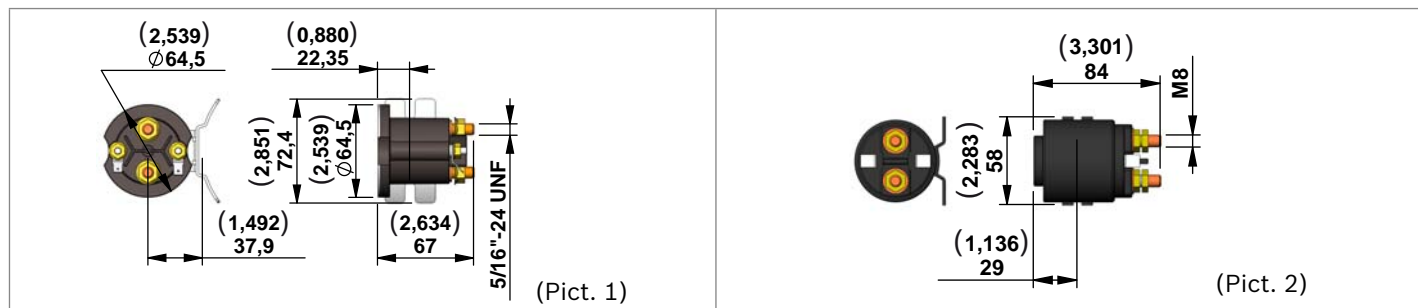

Starting Relay **Standard Performance** (Pict. 1)

Code	Voltage (V)	Nominal Current (A)	Short time Current (A)	Protection INDEX	UL Certified	Type	Material Number
A	Without Relay						
G	24	150	350	IP66	NO	C165534000	R932000692
H	24	150	350	IP66	NO	C165535000	R932000693

Starting Relay **High Performance** (silver plate contact) (Pict. 2)

Code	Voltage (V)	Nominal Current (A)	Short time Current (A)	Protection INDEX	UL Certified	Type	Material Number
A	Without Relay						
C	24	150	350	IP54	NO	C165524000	R932000690
E	24	150	350	IP54	NO	C165525000	R932000691

### Kit Motor + Relay



Motor + Relay	Type	Material Number
<b>C91+relay 12V STANDARD performance</b>	K39681291PSCUF	R932007960
<b>C91+relay 12V HIGH performance</b>	K39681291CF	R932002749
<b>C102+relay 12V STANDARD performance</b>	K396812102PSCUF	R932007969
<b>C102+relay 12V HIGH performance</b>	K396812102CF	R932002715
<b>C92+relay 24V STANDARD performance</b>	K39682492PSCUF	R932007961
<b>C92+relay 24V HIGH performance</b>	K39682492EF	R932002818
<b>C103+relay 24V STANDARD performance</b>	K396824103PSCUF	R932007968
<b>C103+relay 24V HIGH performance</b>	K396824103EF	R932002771

### Plastic Protection

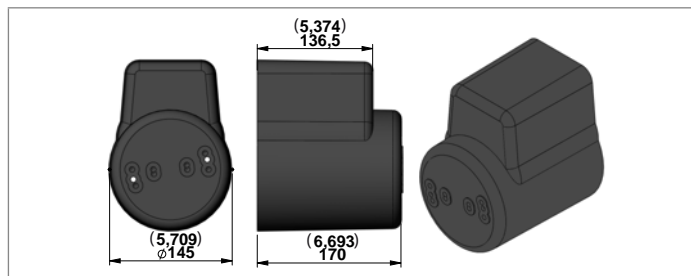

Code	Type	Material Number
0	Without Protection -	-
1	With Protection	K229701000 R932002246

Kit for assembly plastic protection

Type	Material Number
K01K211518000	R932009439

### Junction Elements for D.C. Electric Motor

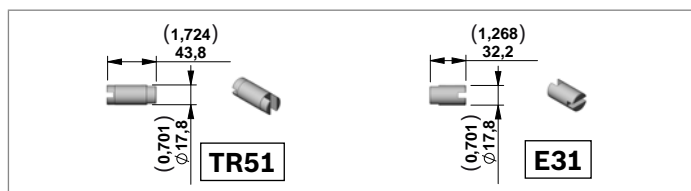

Junction Elements for manifolds

Code	Series	Type	Material Number
TR51	KE - KS	K01KE970TR051	R932001901
E31	K	K01K3970TR008	R932001907

### D.C. Electric Motors High Performance

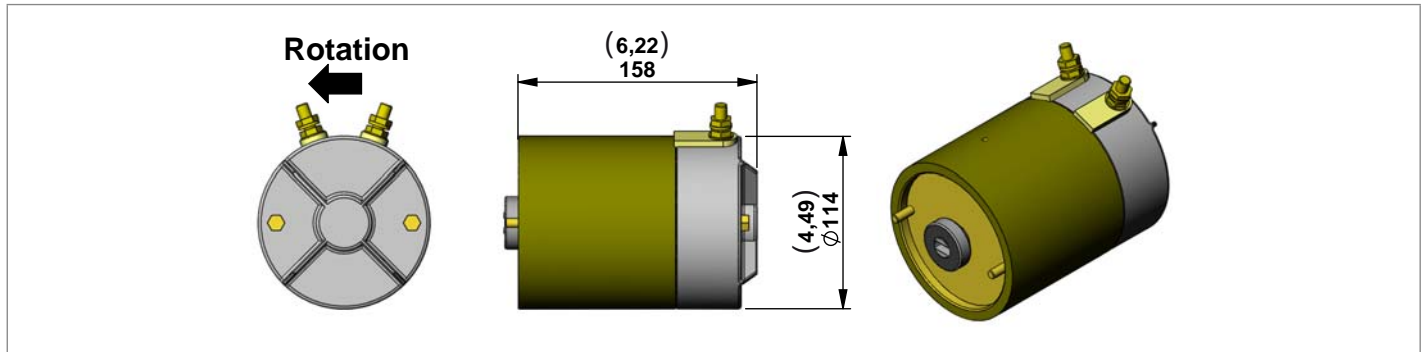

Code	Voltage (V)	Power (W)	Duty Cycle S3% S2 min.	Thermal Switch	UL Certified	Protection index	Type	Material Number
<b>C154</b>	24	2200	4,5% 1,2 min	NO	YES	IP 54	C1620S1A54	R932011151
<b>C164</b>	24	2200	4,5% 1,2 min	YES	NO	IP 54	C1620S1064	R932008439

#### Electric Motor C154-C164 (24V - 2200W) Diagrams

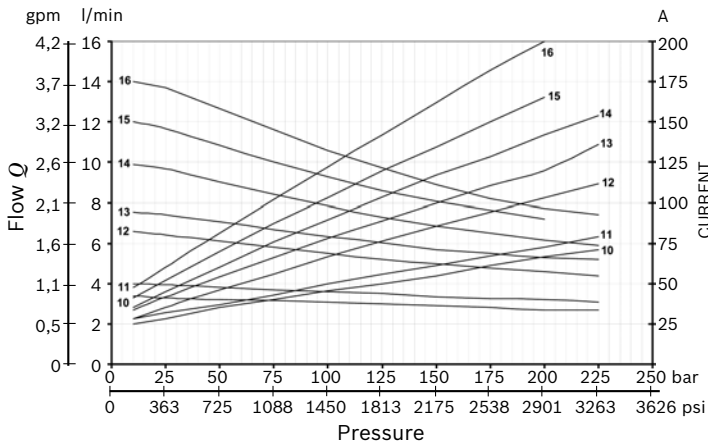

#### S2 - S3 performance

Amps	S2 (min.)	S3(%) (10 min.)
<b>75</b>	5	12%
<b>100</b>	3	7%
<b>125</b>	1,8	5%
<b>150</b>	1	4%
<b>175</b>	0,7	2,5%

#### Note

The values of the curves may change slightly depending on the brand / model of pump that is mounted.

### Relay

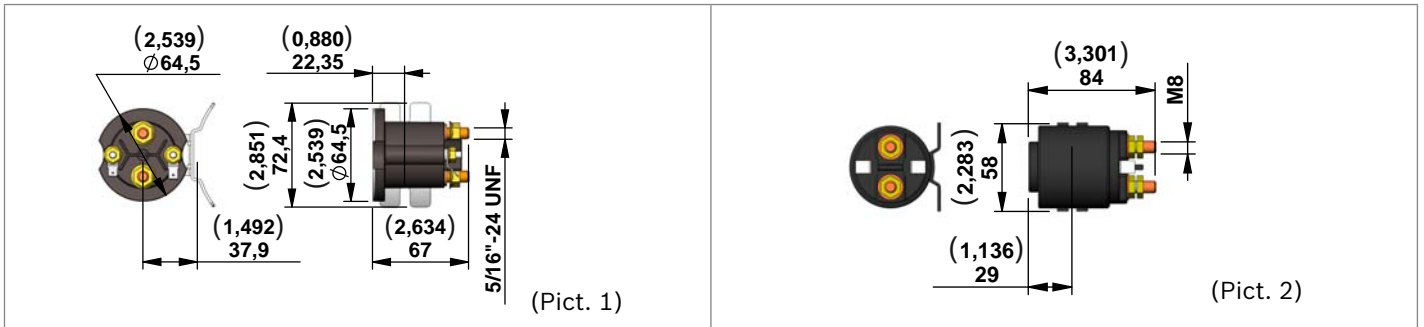

Starting Relay **Standard Performance** (Pict. 1)

Code	Voltage (V)	Nominal Current (A)	Short time Current (A)	Protection INDEX	UL Certified	Type	Material Number
<b>A</b>	Without Relay						
<b>H</b>	24	150	350	IP66	NO	C165535000	R932000693
<b>L</b>	24	150	350	IP66	YES	C165540000	R932008749

Starting Relay **High Performance** (silver plate contact) (Pict. 2)

Code	Voltage (V)	Nominal Current (A)	Short time Current (A)	Protection INDEX	UL Certified	Type	Material Number
<b>A</b>	Without Relay						
<b>E</b>	24	150	350	IP54	NO	C165525000	R932000691

### Kit Motor + Relay



Motor + Relay	Type	Material Number
<b>C154+relay 24V STANDARD performance</b>	K396824154PSF	R930051625
<b>C154+relay 24V STANDARD performance UL certified</b>	K396824154PSFUL	R930051626
<b>C154+relay 24V HIGH performance</b>	K396824154EF	R930051627
<b>C164+relay 24V STANDARD performance</b>	K396824164PSF	R930051628
<b>C164+relay 24V HIGH performance</b>	K396824164EF	R930051986

### Junction Elements for D.C. Electric STD motor flange

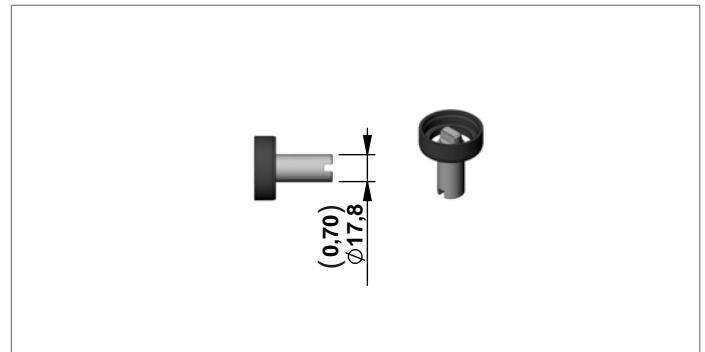

### Junction Elements for manifolds **KE** and **KS series**

Code	Type	Material Number
<b>TR65</b>	K01KE970TR065	R932001905

**Note**

Suitable for KE and KS only.

### D.C. Electric Motors High Performance Fan Cooled

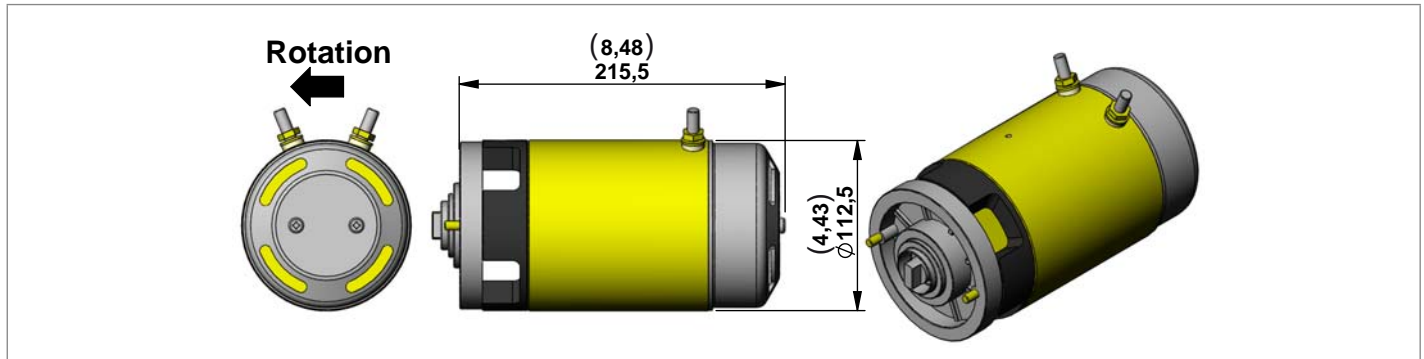

Code	Voltage (V)	Power (W)	Duty Cycle S3% S2 min.	Thermal Switch	UL Certified	Protection index	Type	Material Number
<b>C78</b>	12	1500	14% 4 min	NO	NO	IP 23	C162077000	R932000266
<b>C79</b>	24	2000	10% 4,5 min	NO	NO	IP 23	C162078000	R932000267

#### Electric Motor C78 (12V – 1500W) Diagrams

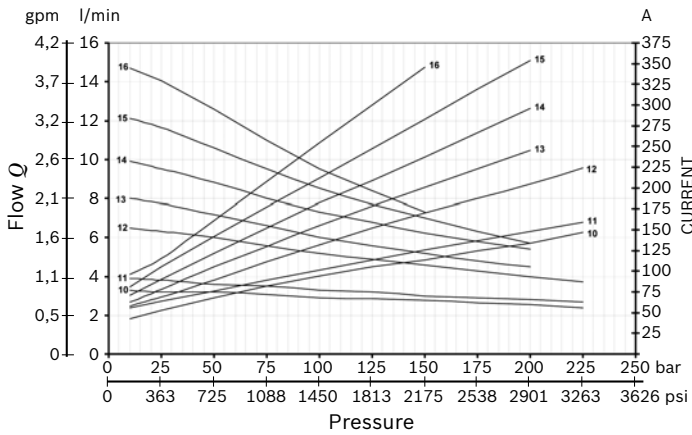

#### Electric Motor C79 (24V – 2000W) Diagrams

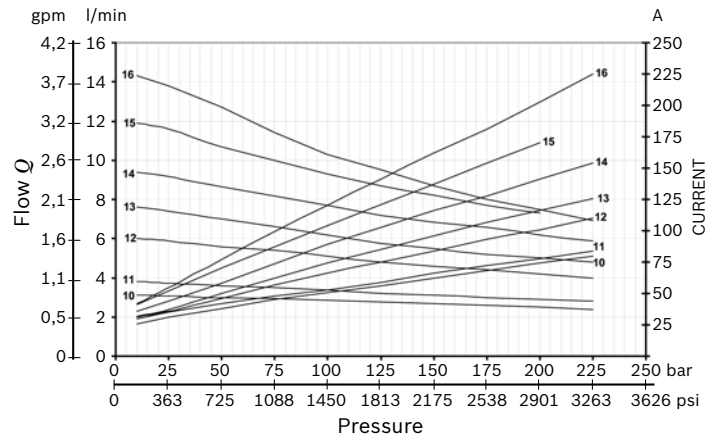

#### S2 - S3 performance

Amps	S2 (min.)	S3(%) (10 min.)
<b>150</b>	10	30%
<b>200</b>	4	15%
<b>250</b>	2	7%
<b>300</b>	1	4%

#### S2 - S3 performance

Amps	S2 (min.)	S3(%) (10 min.)
<b>75</b>	14	40%
<b>100</b>	5	15%
<b>125</b>	3,5	10%
<b>150</b>	2	6%
<b>175</b>	1	5%

#### Note

The values of the curves may change slightly depending on the brand / model of pump that is mounted.



### Relay

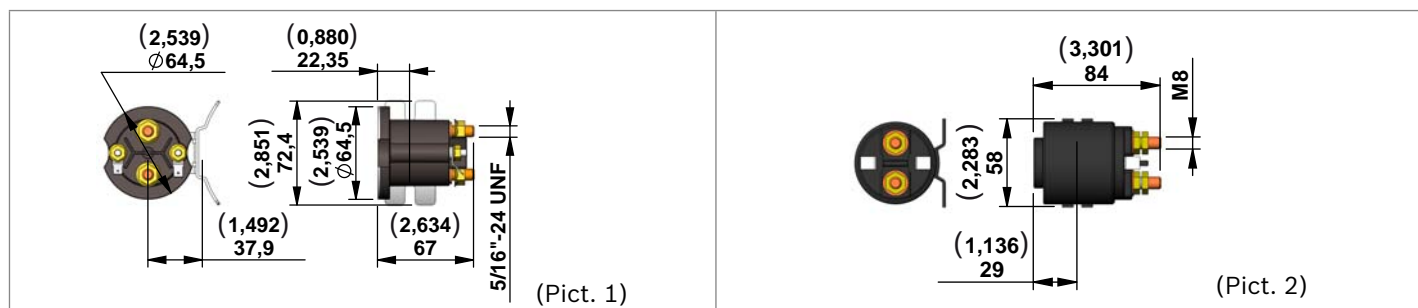

Starting Relay **Standard Performance** (Pict. 1)

Code	Voltage (V)	Nominal Current (A)	Short time Current (A)	Protection INDEX	UL Certified	Type	Material Number
<b>A</b>	Without Relay						
<b>G</b>	12	150	350	IP66	NO	C165534000	R932000692
<b>H</b>	24	150	350	IP66	NO	C165535000	R932000693

Starting Relay **High Performance** (silver plate contact) (Pict. 2)

Code	Voltage (V)	Nominal Current (A)	Short time Current (A)	Protection INDEX	UL Certified	Type	Material Number
<b>A</b>	Without Relay						
<b>C</b>	12	150	350	IP54	NO	C165524000	R932000690
<b>E</b>	24	150	350	IP54	NO	C165525000	R932000691

### Kit Motor + Relay



Motor + Relay	Type	Material Number
<b>C78+relay 12V STANDARD performance</b>	K39681278PSF	R930051640
<b>C78+relay 12V HIGH performance</b>	K39681278CF	R932002743
<b>C79+relay 24V STANDARD performance</b>	K39682479PSF	R932002811
<b>C79+relay 24V HIGH performance</b>	K39682479EF	R932002810

### Junction Elements for D.C. Electric Motor

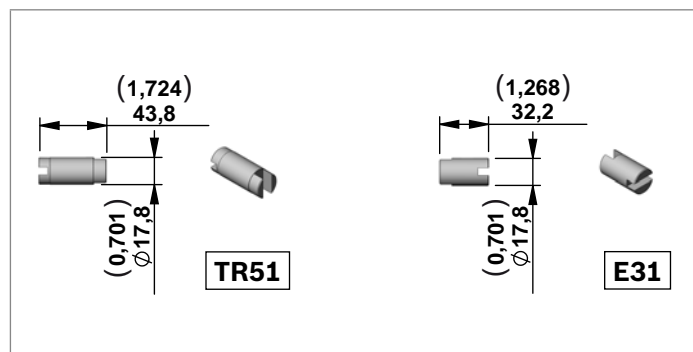

Junction Elements for manifolds

Code	Series	Type	Material Number
<b>TR51</b>	<b>KE - KS</b>	K01KE970TR051	R932001901
<b>E31</b>	<b>K</b>	K01K3970TR008	R932001907

### D.C. Electric Motors High Performance

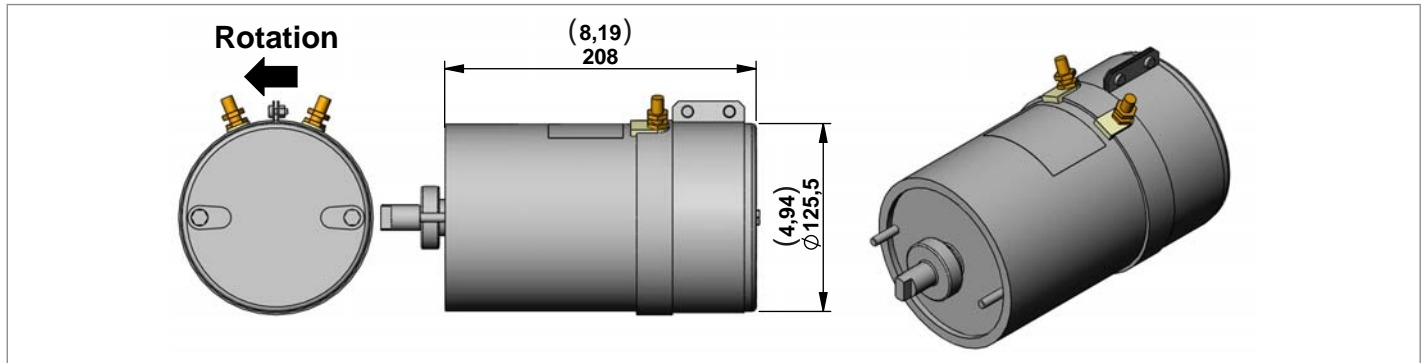

Code	Voltage (V)	Power (W)	Duty Cycle S3% S2 min.	Thermal Switch	UL Certified	Protection index	Type	Material Number
<b>C163</b>	24	3000	9% 5 min.	NO	YES	IP 43	C1620S1063	R932009387

#### Electric Motor C163 (24V – 3000W) Diagrams

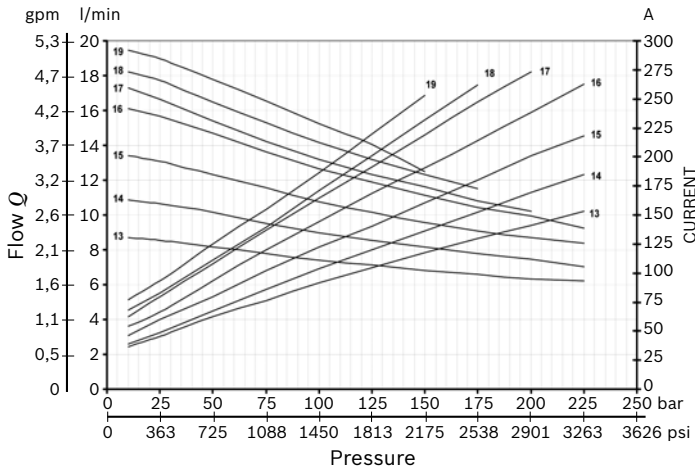

#### S2 - S3 performance

Amps	S2 (min.)	S3(%) (10 min.)
<b>125</b>	11	20%
<b>150</b>	7	13%
<b>175</b>	5	10%
<b>200</b>	3,5	8%
<b>250</b>	2,2	5%

#### Note

The values of the curves may change slightly depending on the brand / model of pump that is mounted.

### Relay

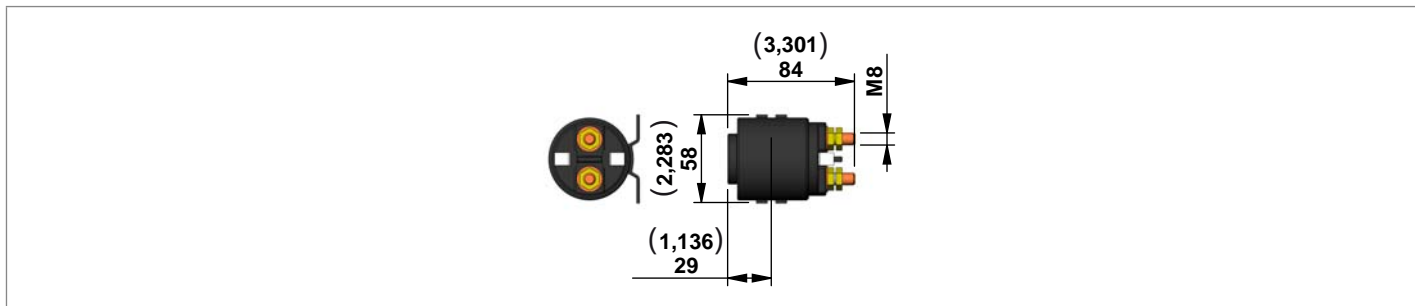

Starting Relay **High Performance** (silver plate contact)

Code	Voltage (V)	Nominal Current (A)	Short time Current (A)	Protection INDEX	UL Certified	Type	Material Number
A	Without Relay						
E	24	150	350	IP54	NO	C165525000	R932000691

### Kit Motor + Relay



Motor + Relay	Type	Material Number
<b>C163+relay 24V HIGH performance</b>	K396824163E	R930042326

### Junction Elements for D.C. Electric Motor Standard Flange

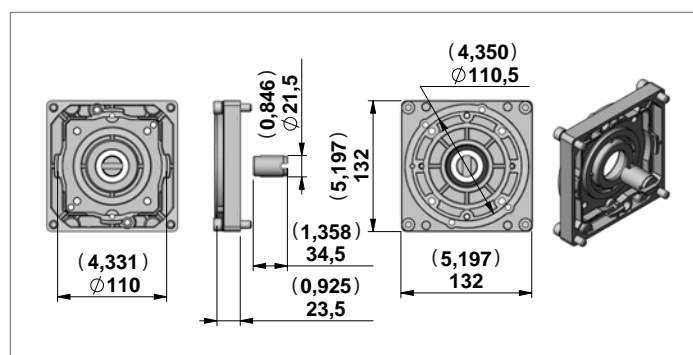

Junction Elements for manifolds **KE** and **KS** series

Code	Series	Type	Material Number
<b>TR54</b>	<b>KE - KS</b>	K01KE970TR054	R932001904

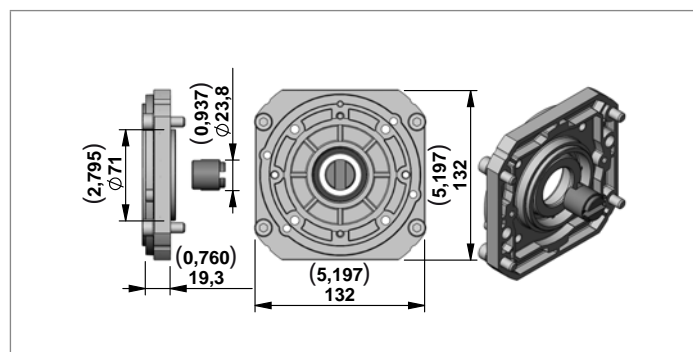

Junction Elements for manifolds **K** series

Code	Series	Type	Material Number
<b>E62</b>	<b>K</b>	K01K3970TR107	R932001936

### D.C. Electric Motors Low Noise High Performance

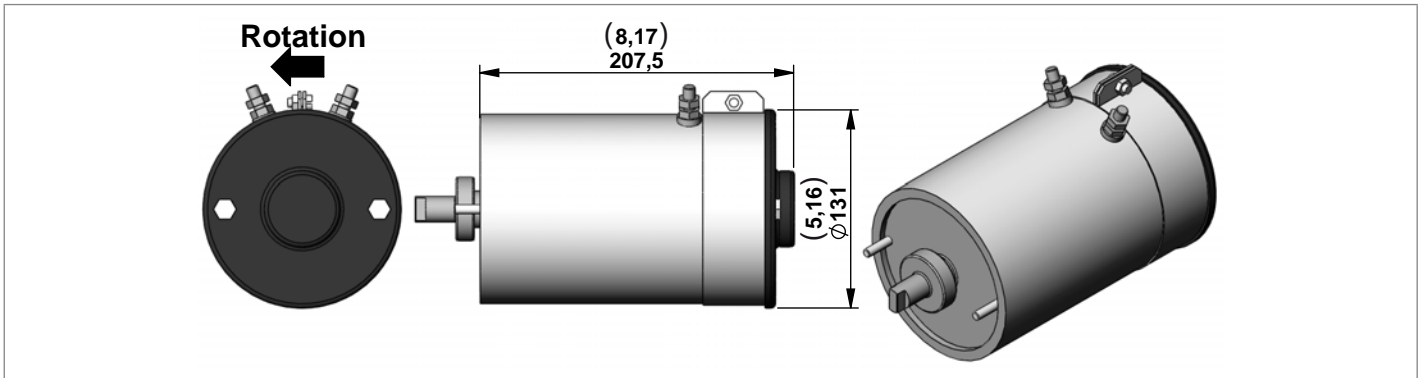

Code	Voltage (V)	Power (W)	Duty Cycle S3% S2 min.	Thermal Switch	UL Certified	Protection index	Type	Material Number
<b>C151</b>	24	3000	8% 4 min	NO	NO	IP 44	C1620S1047	R932000240
<b>C140</b>	24	3000	8% 4 min	YES	NO	IP 44	C1620S1040	R932000235

#### Electric Motor C151-C140 (24V – 3000W) Diagrams

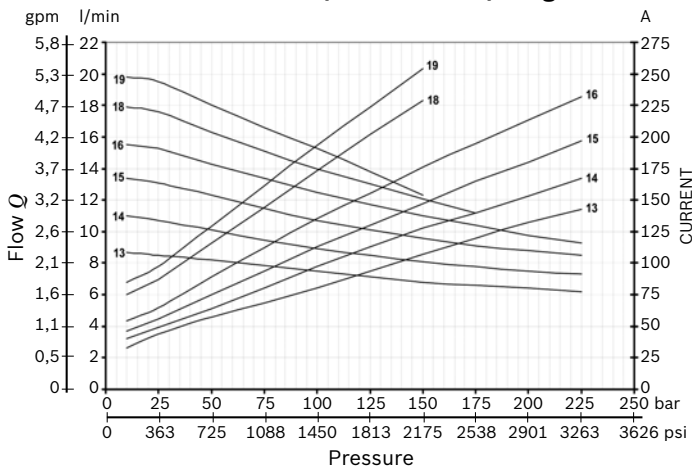

#### S2 - S3 performance

Amps	S2 (min.)	S3(%) (10 min.)
<b>75</b>	18	25%
<b>100</b>	12	17%
<b>125</b>	8,5	13%
<b>150</b>	6	10%
<b>175</b>	5	8%
<b>200</b>	4	7%

#### Note

The values of the curves may change slightly depending on the brand / model of pump that is mounted.

**Relay**

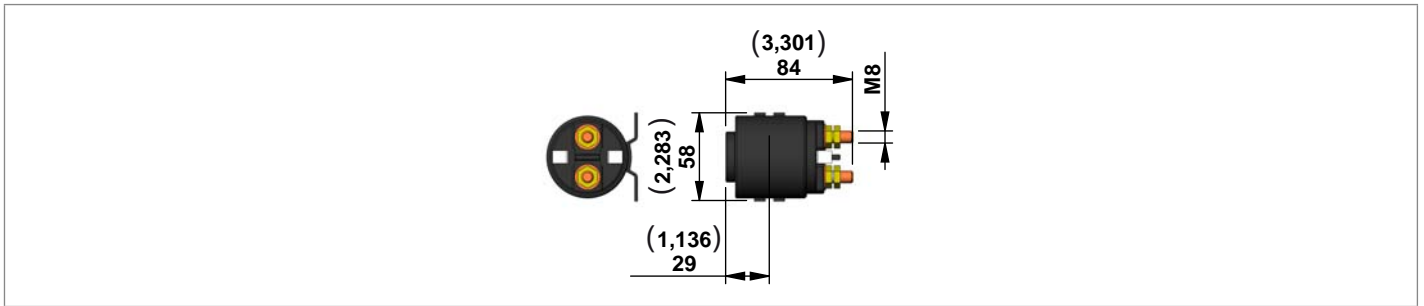

Starting Relay **High Performance** (silver plate contact)

Code	Voltage (V)	Nominal Current (A)	Short time Current (A)	Protection INDEX	UL Certified	Type	Material Number
A	Without Relay						
E	24	150	350	IP54	NO	C165525000	R932000691

**Kit Motor + Relay**

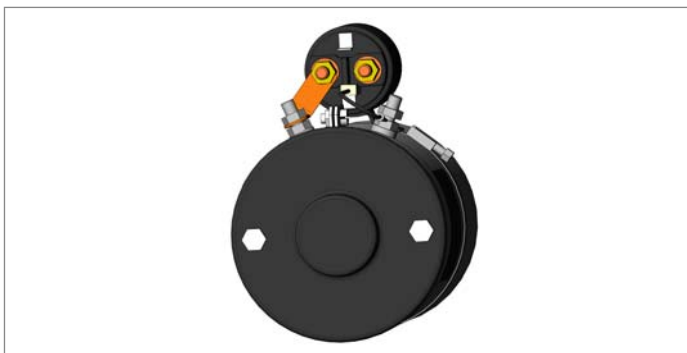

Motor + Relay	Type	Material Number
<b>C151+relay 24V HIGH performance</b>	K396824151E	R932002800
<b>C140+relay 24V HIGH performance</b>	K396824140E	R932002788

**Junction Elements for D.C. Electric Motor Standard Flange**

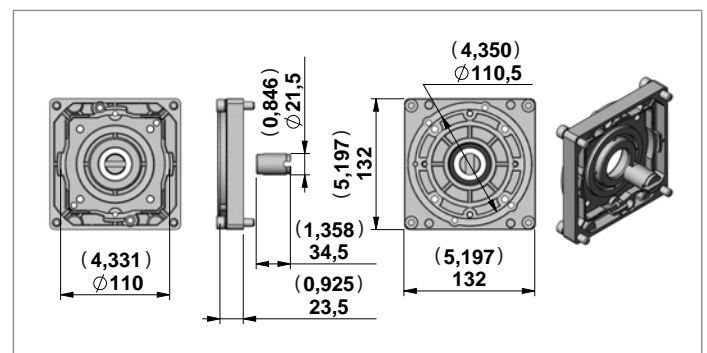

Junction Elements for manifolds **KE** and **KS** series

Code	Series	Type	Material Number
<b>TR54</b>	<b>KE - KS</b>	K01KE970TR054	R932001904

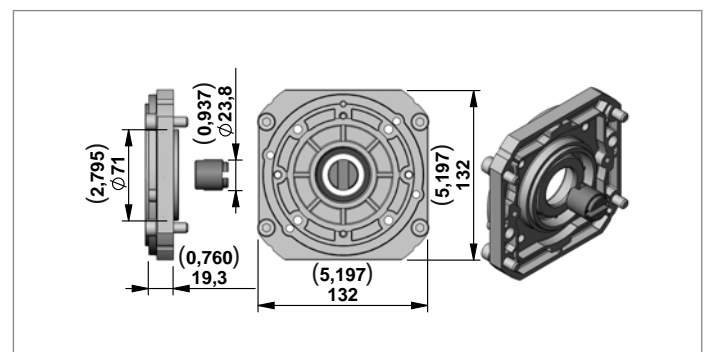

Junction Elements for manifolds **K** series

Code	Series	Type	Material Number
<b>E62</b>	<b>K</b>	K01K3970TR107	R932001936

### D.C. Electric Motors High Performance Fan Cooled

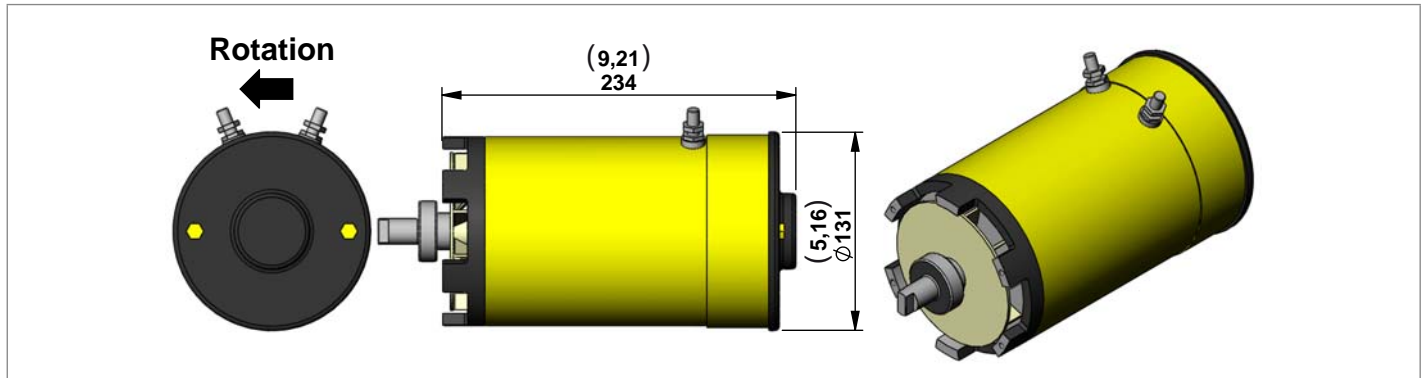

Code	Voltage (V)	Power (W)	Duty Cycle S3% S2 min.	Thermal Switch	UL Certified	Protection index	Type	Material Number
<b>C111</b>	24	3000	20% 6 min	NO	NO	IP 12	C1620S1011	R932000208

#### Electric Motor C111 (24V – 3000W) Diagrams

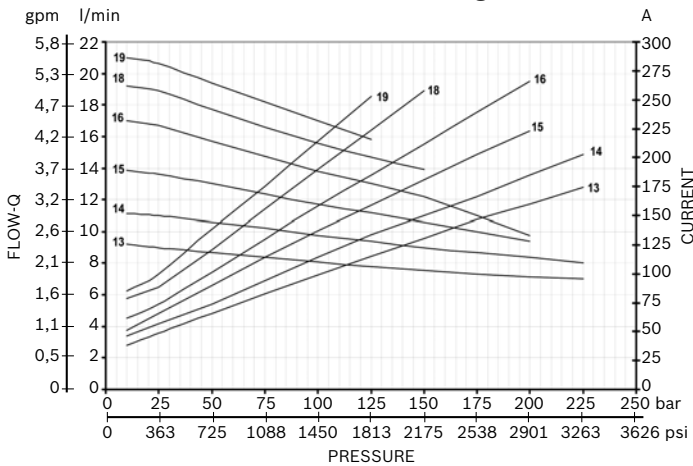

#### S2 - S3 performance

Amps	S2 (min.)	S3(%) (10 min.)
<b>125</b>	20	55%
<b>150</b>	10	32%
<b>175</b>	7,5	25%
<b>200</b>	4,5	15%
<b>250</b>	3	10%

#### Note

The values of the curves may change slightly depending on the brand / model of pump that is mounted.

### Relay

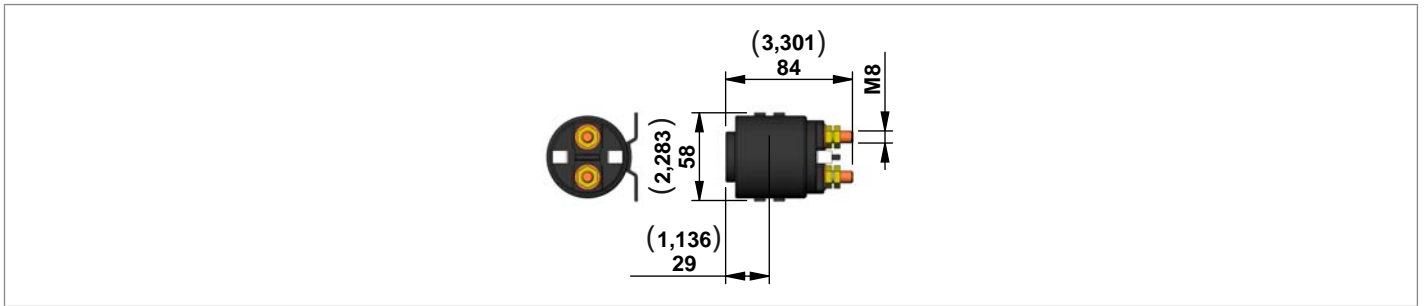

Starting Relay **High Performance** (silver plate contact)

Code	Voltage (V)	Nominal Current (A)	Short time Current (A)	Protection INDEX	UL Certified	Type	Material Number
A	Without Relay						
E	24	150	350	IP54	NO	C165525000	R932000691

### Kit Motor + Relay

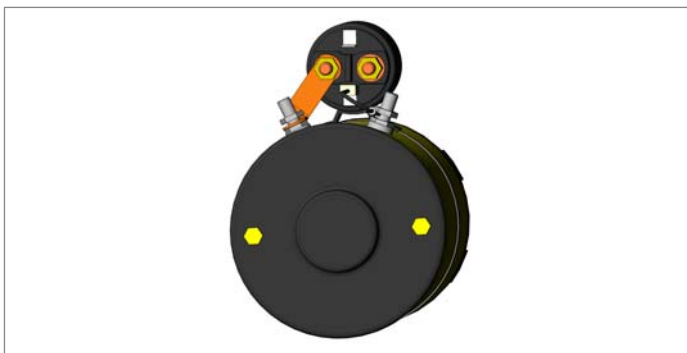

Motor + Relay	Type	Material Number
<b>C111+relay 24V HIGH performance</b>	K396824111E	R932002777

### Junction Elements for D.C. Electric Motor Standard Flange

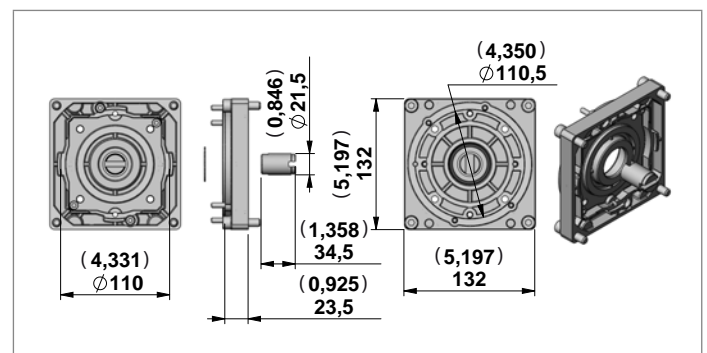

Junction Elements for manifolds **KE** and **KS** series

Code	Series	Type	Material Number
<b>TR53</b>	<b>KE - KS</b>	K01KE970TR053	R932001903

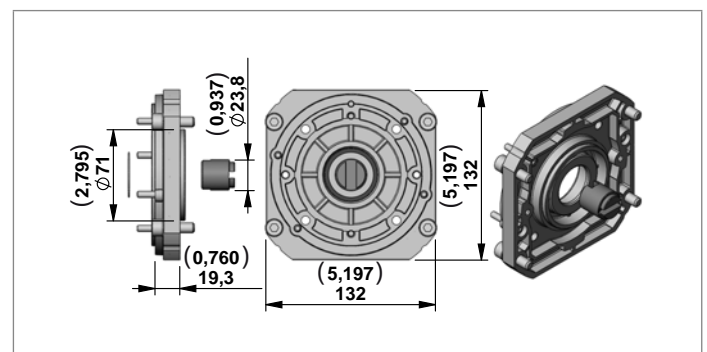

Junction Elements for manifolds **K** series

Code	Series	Type	Material Number
<b>E63</b>	<b>K</b>	K01K3970TR085	R932001927

## Central Manifold KE

### M02

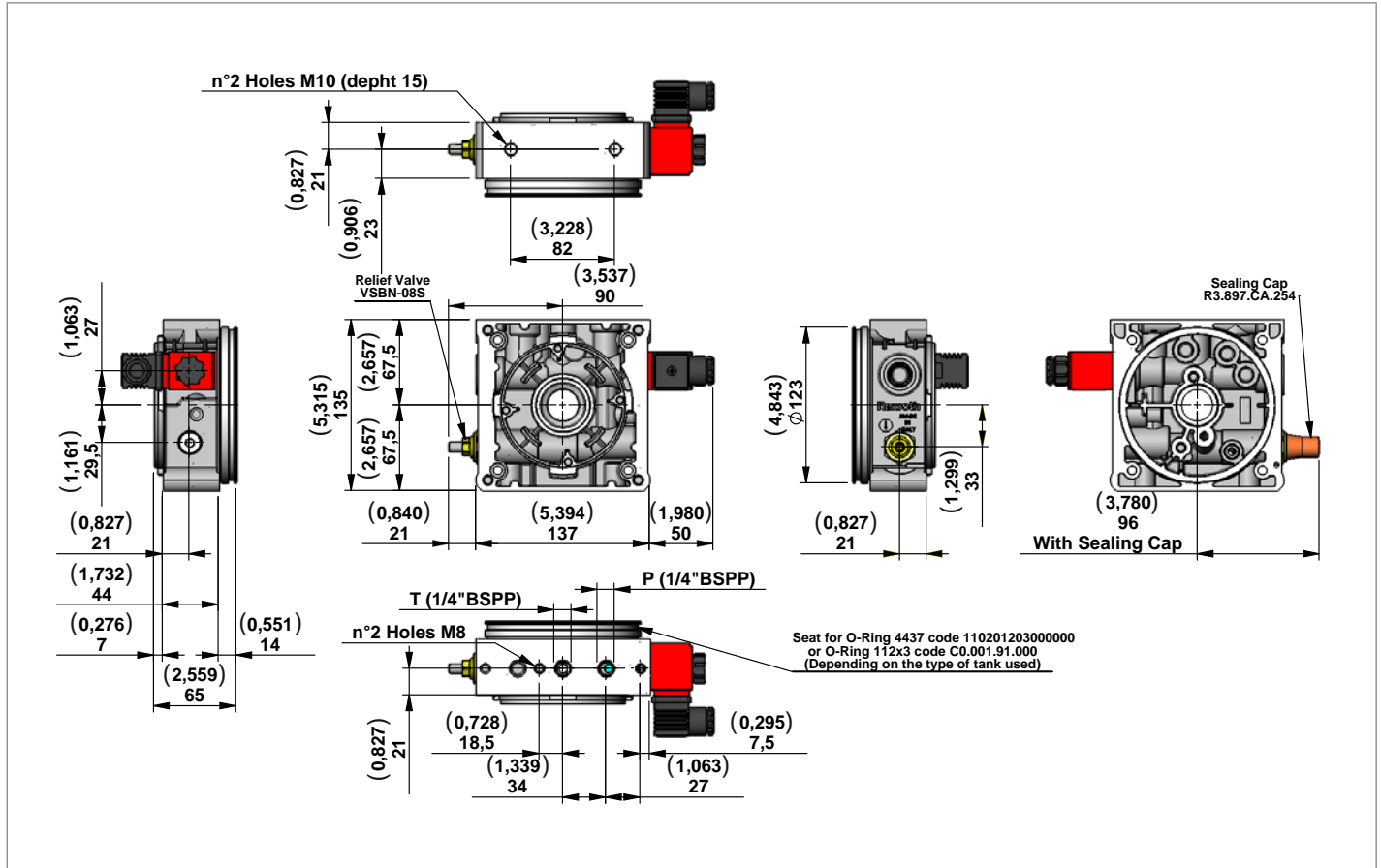

Manifold Code with Relief Valve Pressure Range	Pressure Range bar (psi)	Type	Material Number
<b>M02/05</b>	10-55 (145-798)	202A000	R930052187
<b>M02/10</b>	35-100 (508-1450)	202B000	R930052188
<b>M02/20</b>	90-250 (1305-3626)	202C000	R930052190
<b>M02/35</b>	175-345 (2538-5004)	202D000	R930052191

### View Manifold Tank side

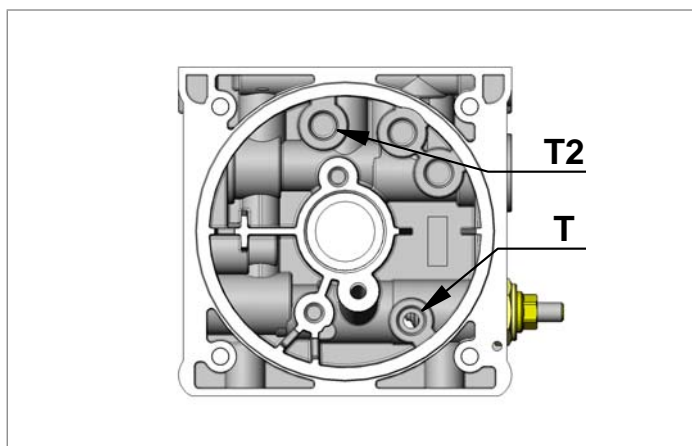

### Manifold Hydraulic Diagram

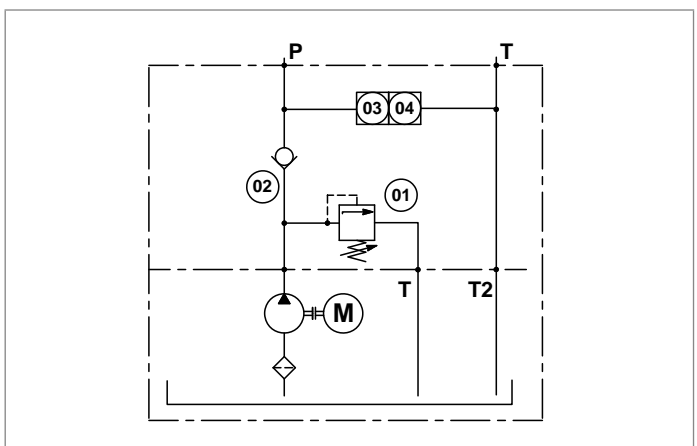



**M02 with valves**

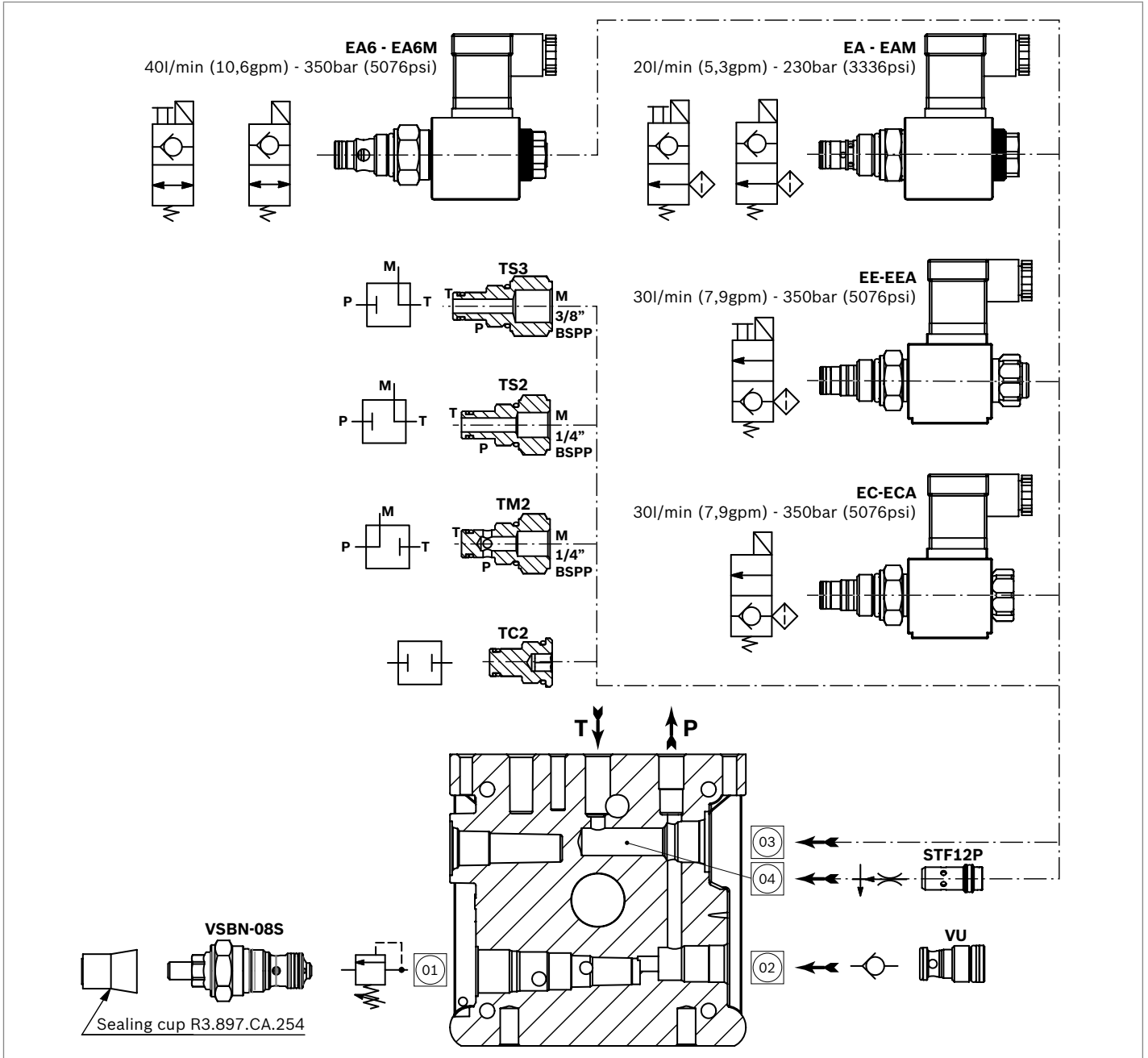

**Main Realizable Diagrams**

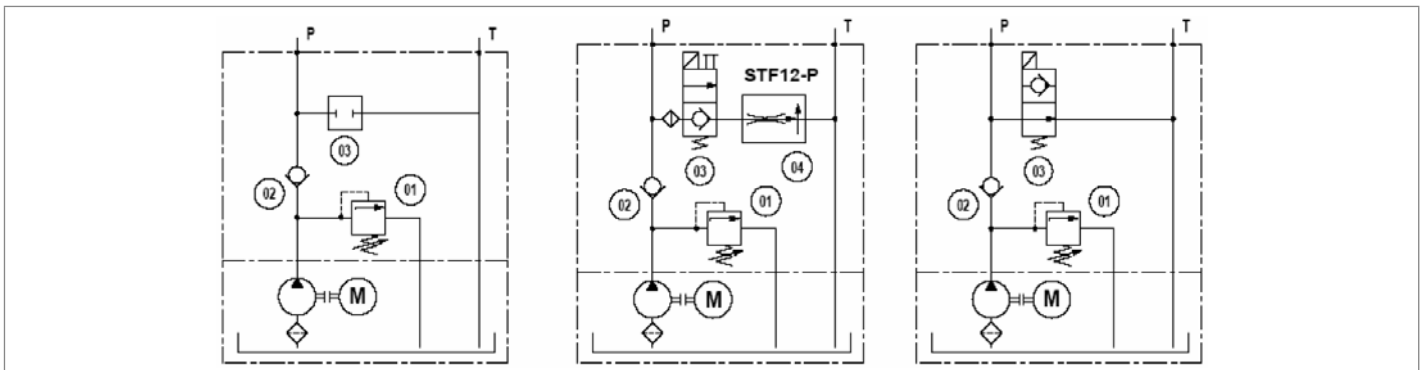

## Central Manifold KE

### M03

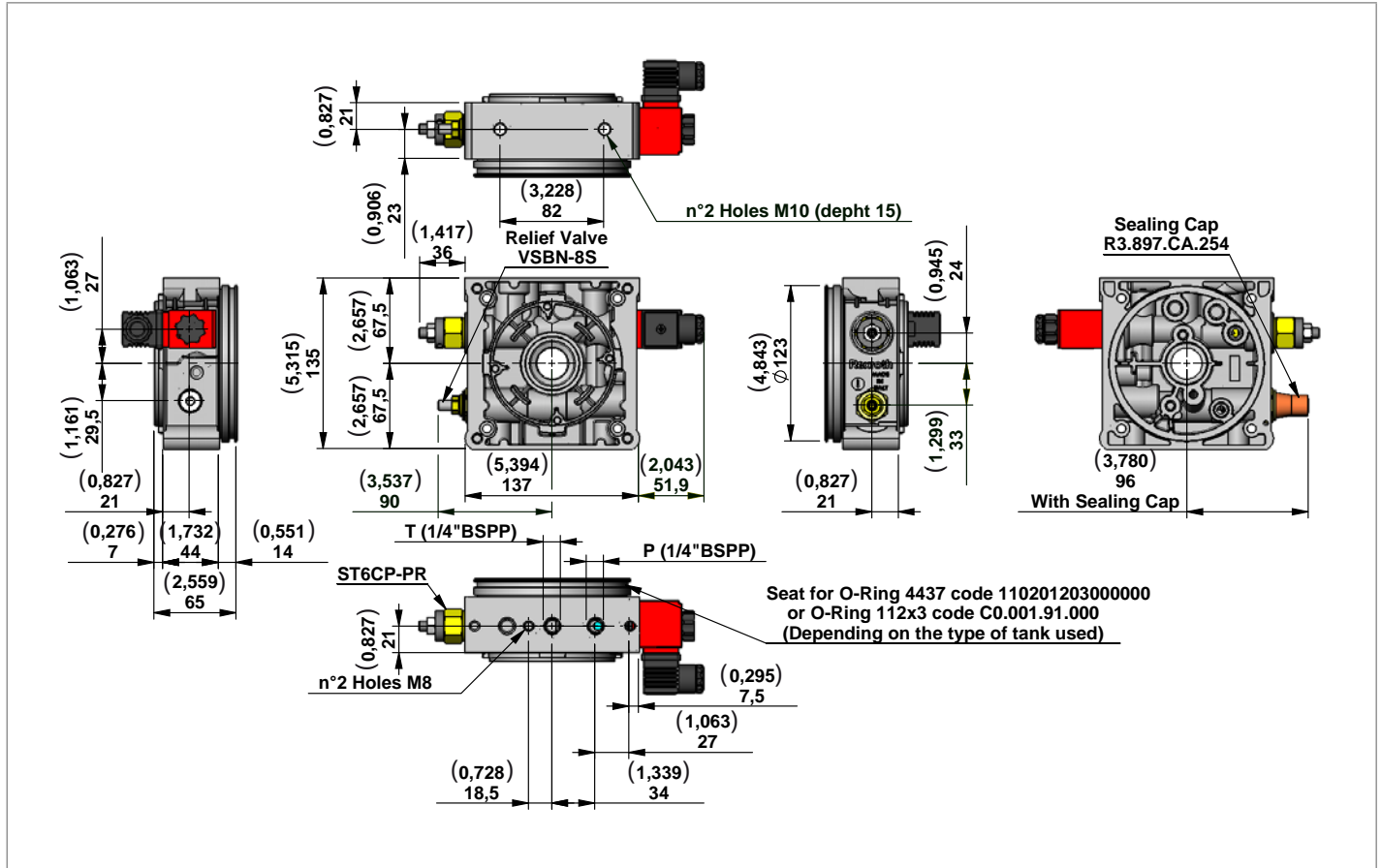

Manifold Code with Relief Valve Pressure Range	Pressure Range bar (psi)	Type	Material Number
M03/05	10-55 (145-798)	203A000	R930052192
M03/10	35-100 (508-1450)	203B000	R930052286
M03/20	90-250 (1305-3626)	203C000	R930052193
M03/35	175-345 (2538-5004)	203D000	R930052194

### View Manifold Tank side

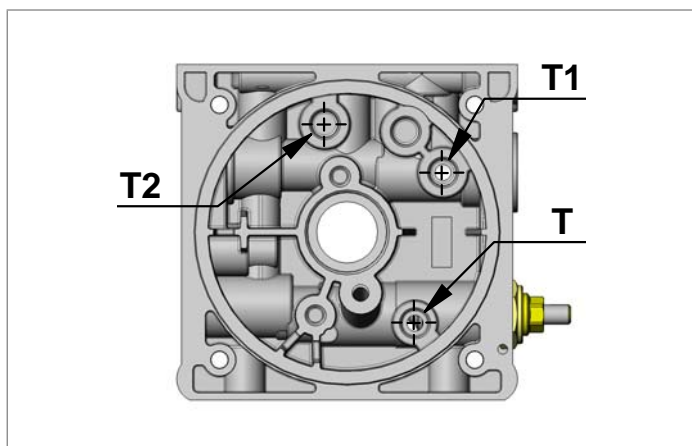

### Manifold Hydraulic Diagram

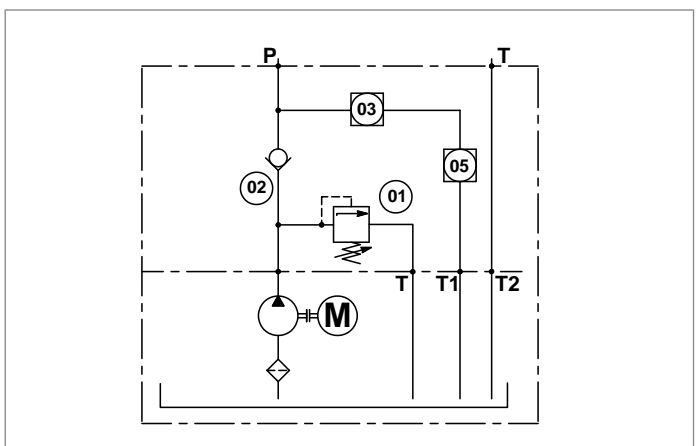

**M03 with valves**

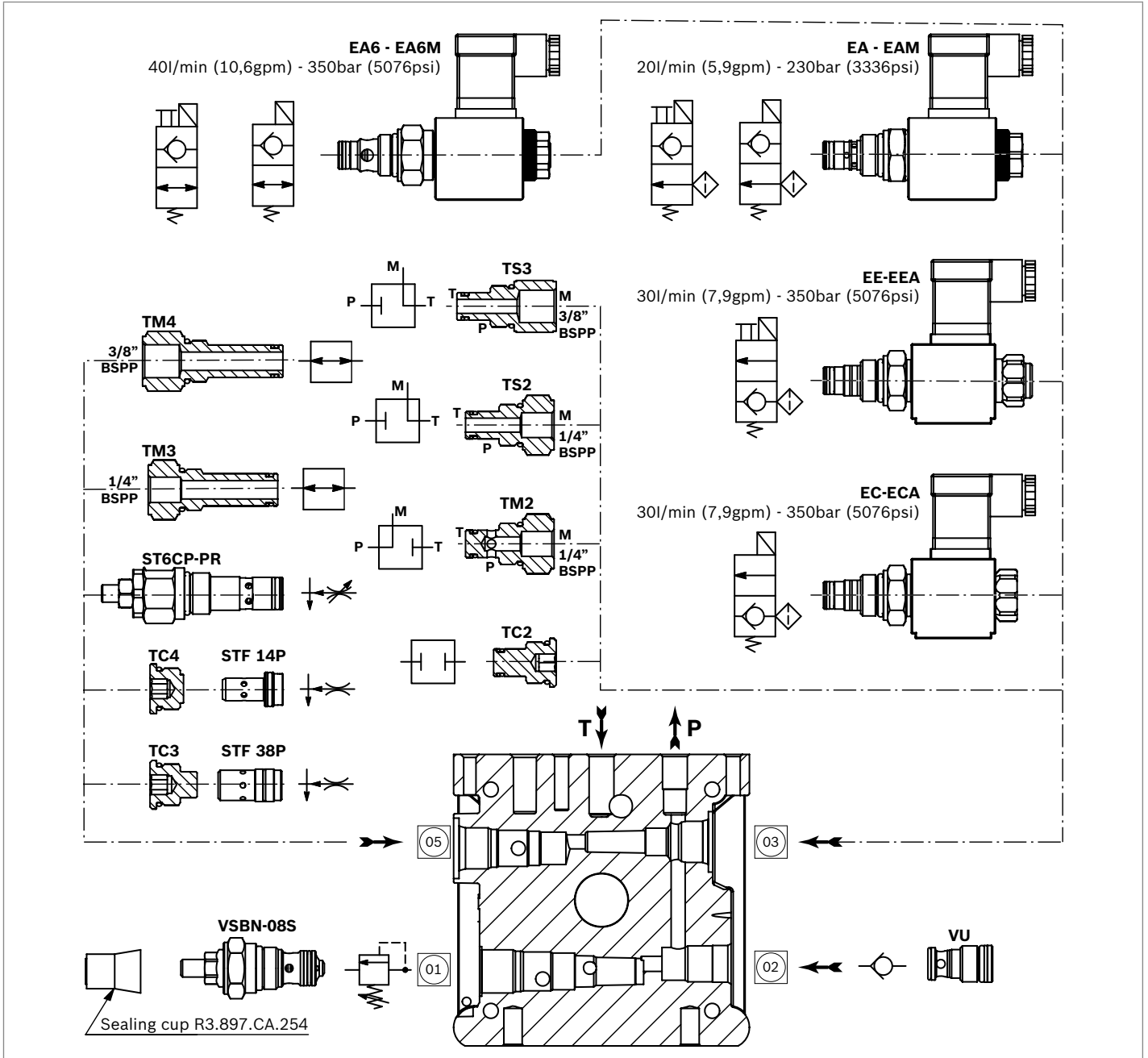

**Main Realizable Diagrams**

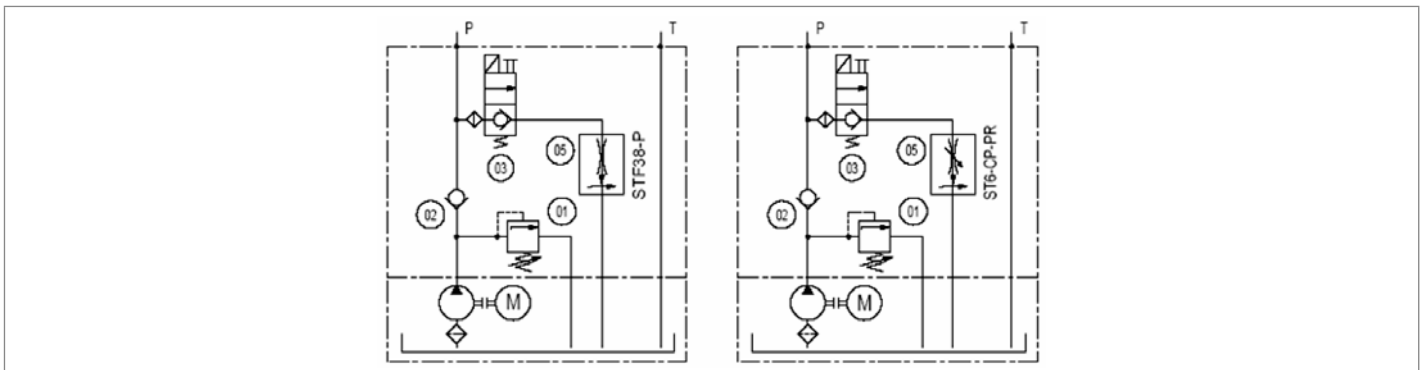

## Central Manifold KE

### M09

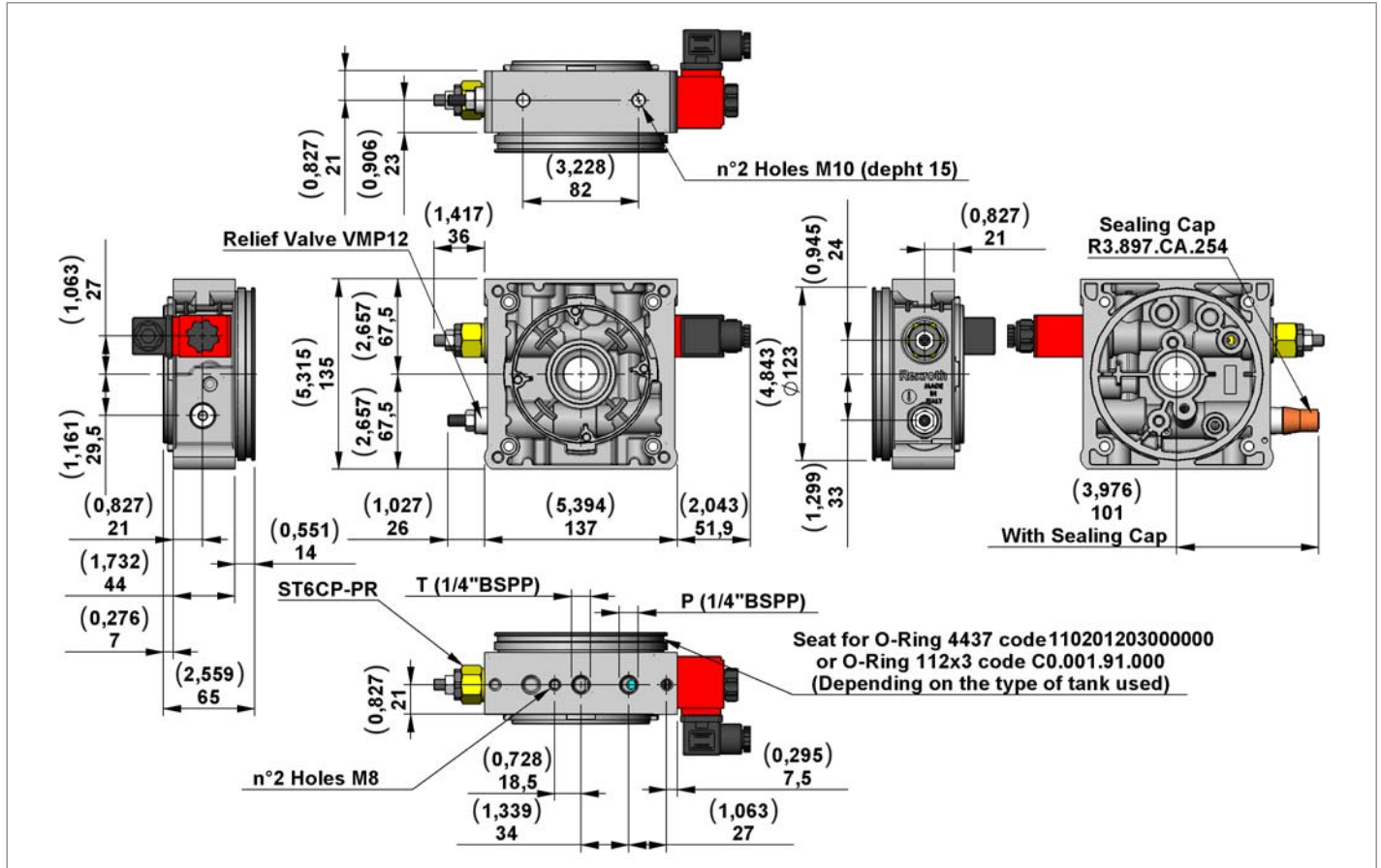

Manifold Code with Relief Valve Pressure Range	Pressure Range bar (psi)	Closing Flow l/min (gpm)	Pump displacement at 1450 rpm cc/rev	Flow at 1450 rpm l/min (gpm)	Pump displacement at 2850 rpm cc/rev	Flow at 2850 rpm l/min (gpm)	Type	Material Number
<b>M09/13</b>	80-300 (1160-4351)	1,1 (0,29)	1,1 (11)	1,6 (0,42)	-	-	209I00013	R932010272
<b>M09/16</b>	80-300 (1160-4351)	1,7 (0,45)	1,6 (12)	2,3 (0,61)	-	-	209I00016	R932008838
<b>M09/17</b>	80-300 (1160-4351)	2 (0,53)	2 (13)	2,9 (0,77)	1,1 (11)	3,2 (0,85)	209I00017	R932008839
<b>M09/18</b>	80-300 (1160-4351)	2,3 (0,61)	2,5 (14)	3,6 (0,95)	-	-	209I00018	R932008840
<b>M09/22</b>	80-300 (1160-4351)	3,5 (0,92)	3,15 (15)	4,6 (1,22)	1,6 (12)	4,6 (1,22)	209I00022	R930052412
<b>M09/25</b>	80-300 (1160-4351)	4,2 (1,11)	4 (16)	5,8 (1,53)	2 (13)	5,7 (1,51)	209I00025	R932010299

### View Manifold Tank side

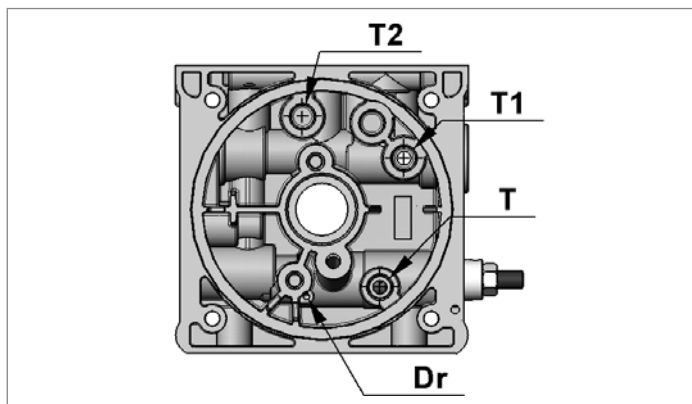

### Manifold Hydraulic Diagram

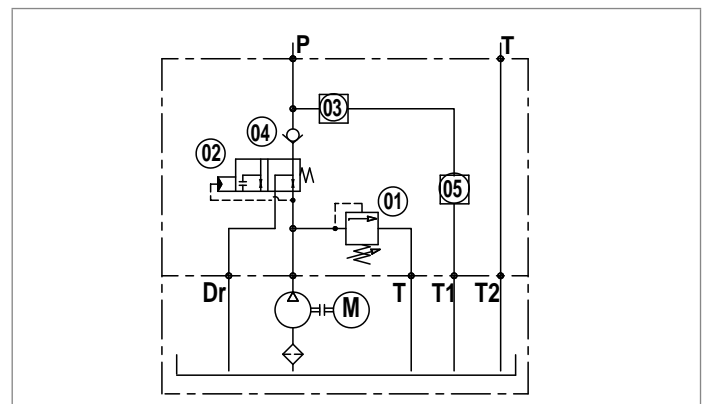

**M09 with valves**

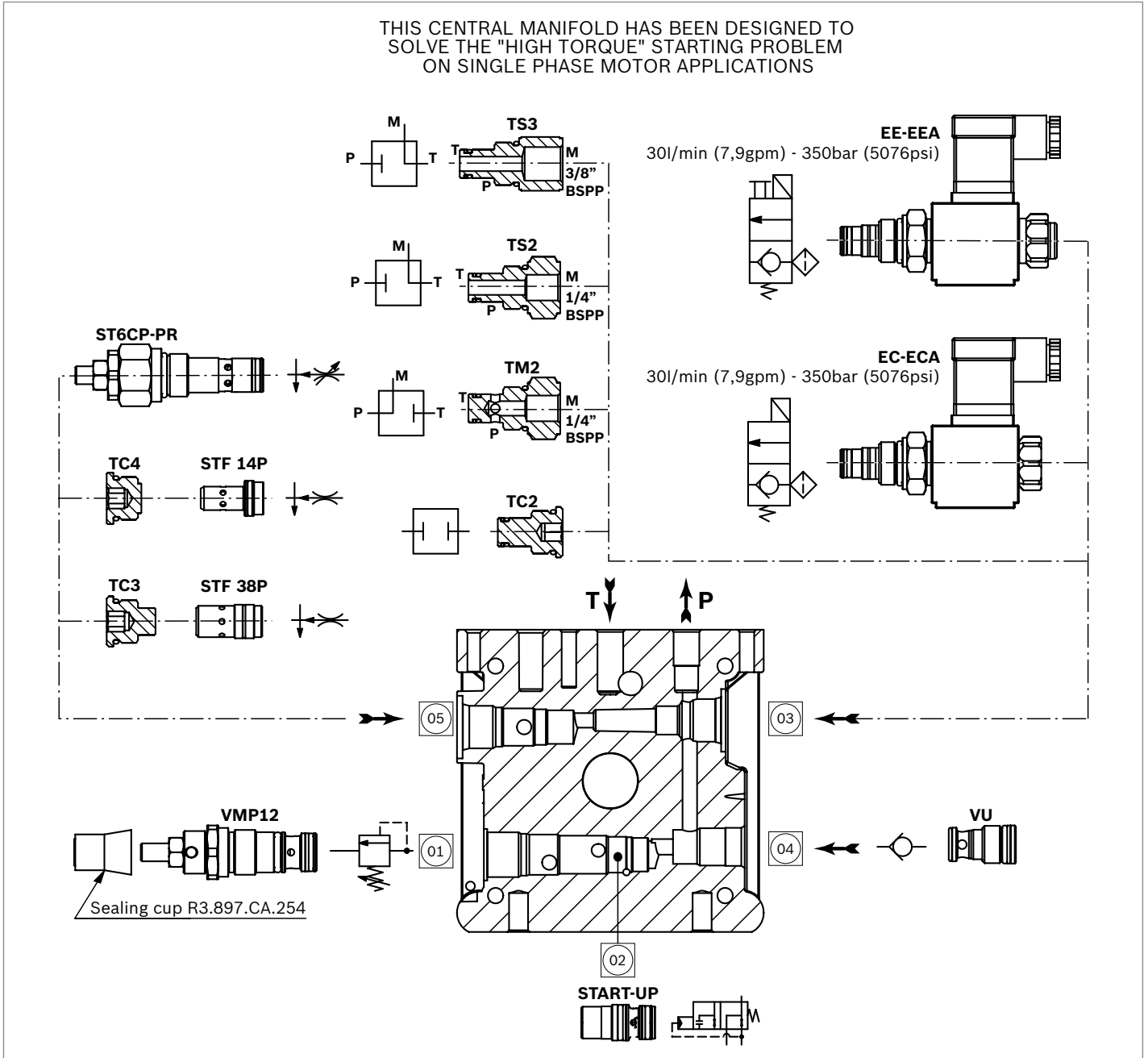

**Main Realizable Diagrams**

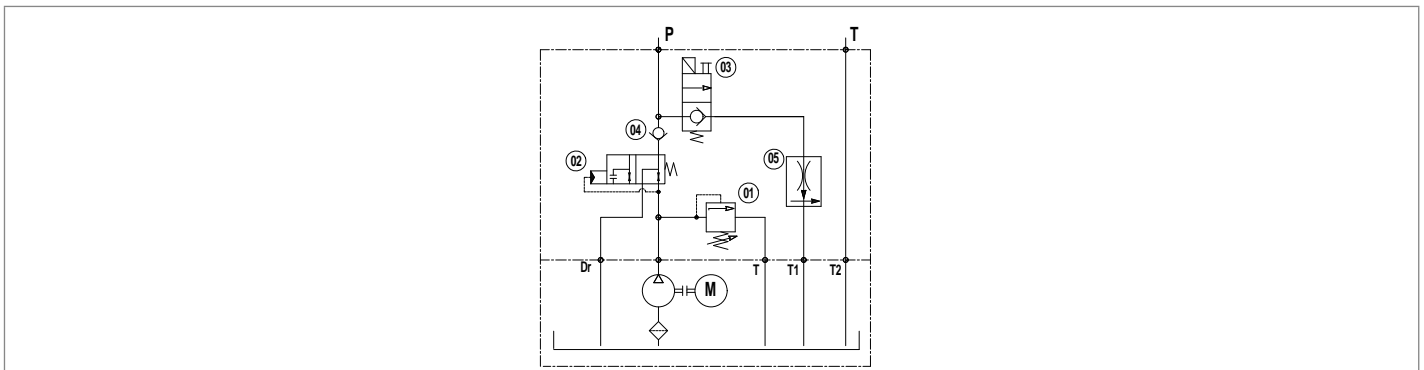

## Central Manifold KE

### M04

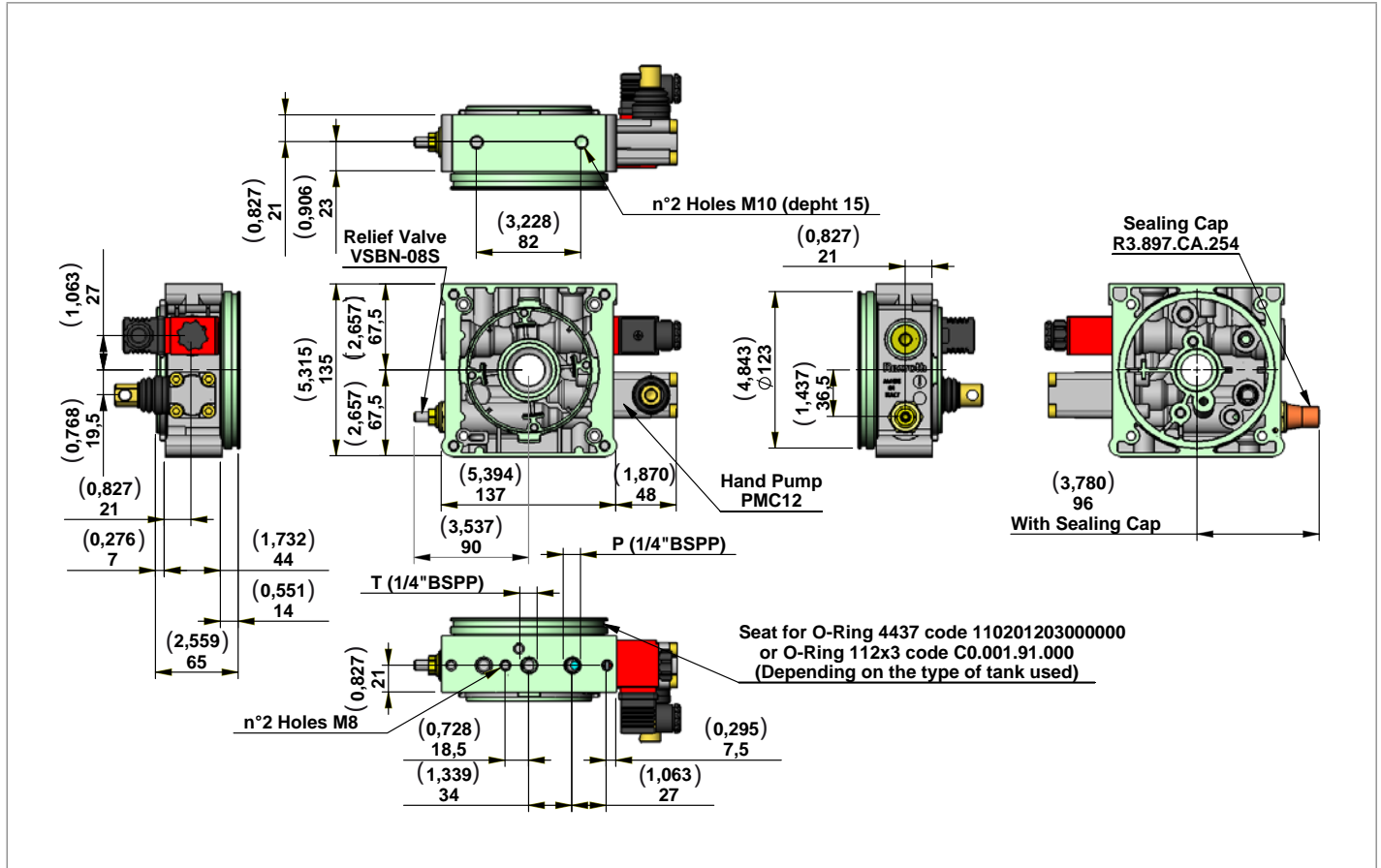

Manifold Code with Relief Valve Pressure Range	Pressure Range bar (psi)	Type	Material Number
M04/05	10-55 (145-798)	204A000	R930052195
M04/10	35-100 (508-1450)	204B000	R930052196
M04/20	90-250 (1305-3626)	204C000	R930052197
M04/35	175-345 (2538-5004)	204D000	R930052198

### View Manifold Tank side

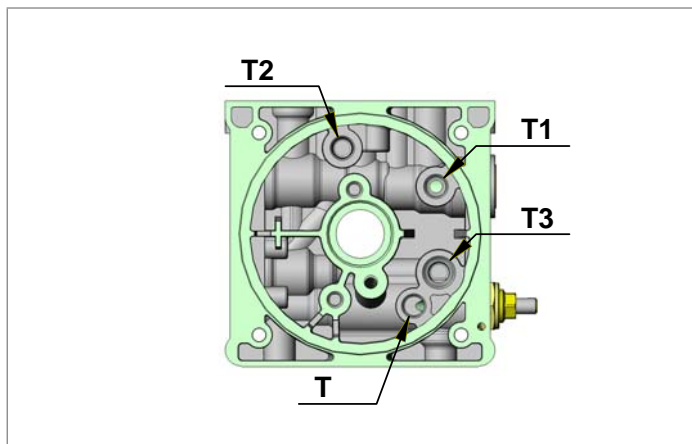

### Manifold Hydraulic Diagram

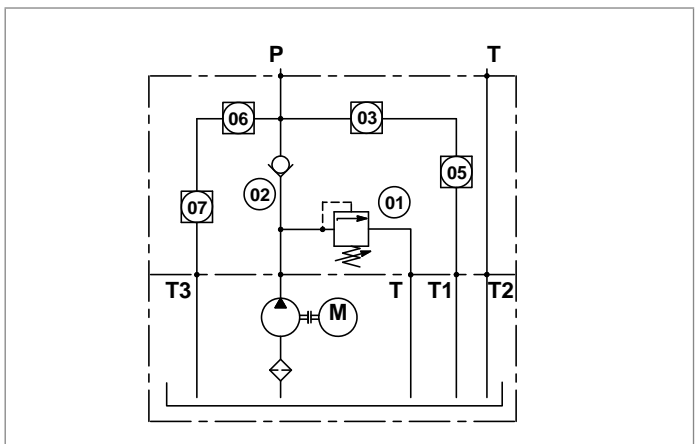

**M04 with valves**

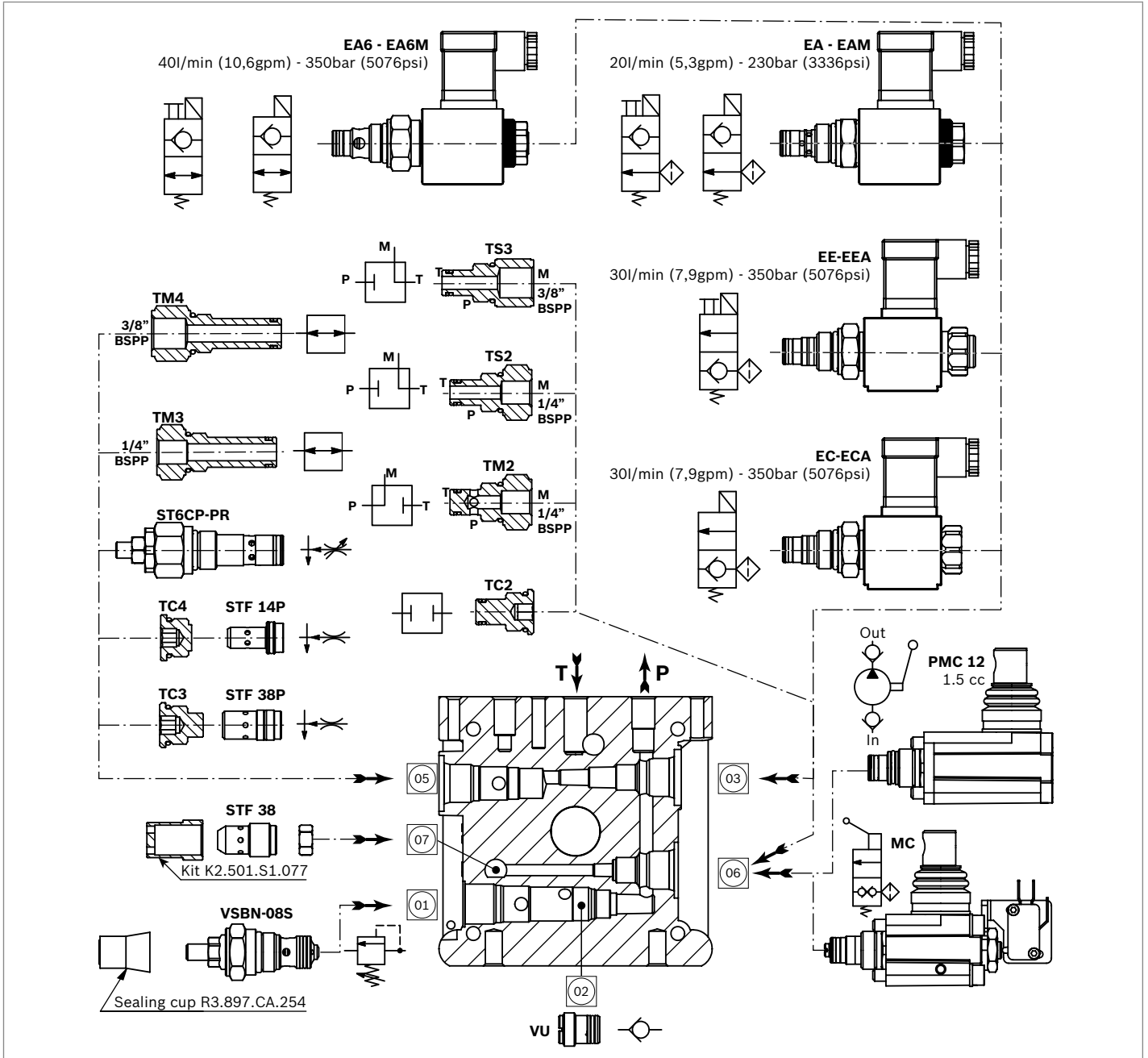

**Main Realizable Diagrams**

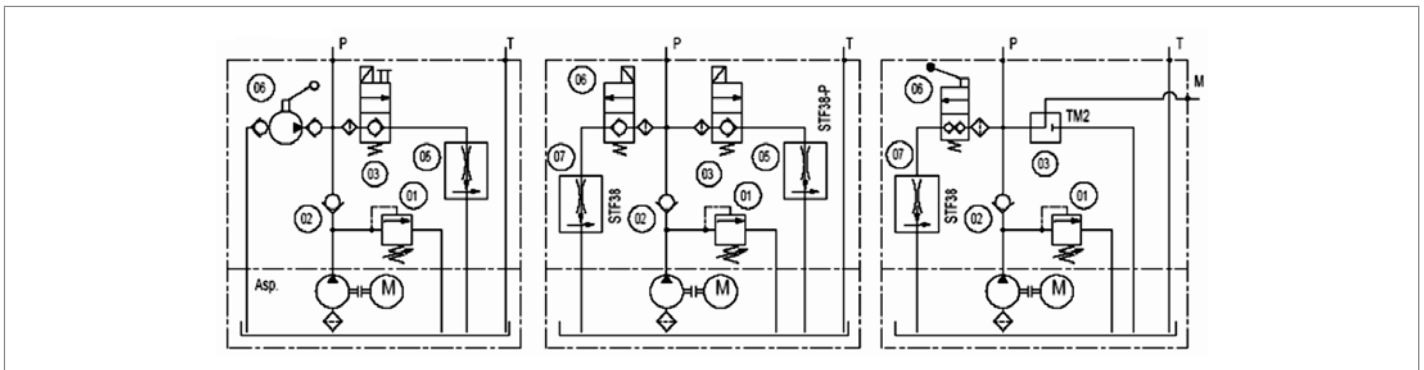

## Central Manifold KE

### M05

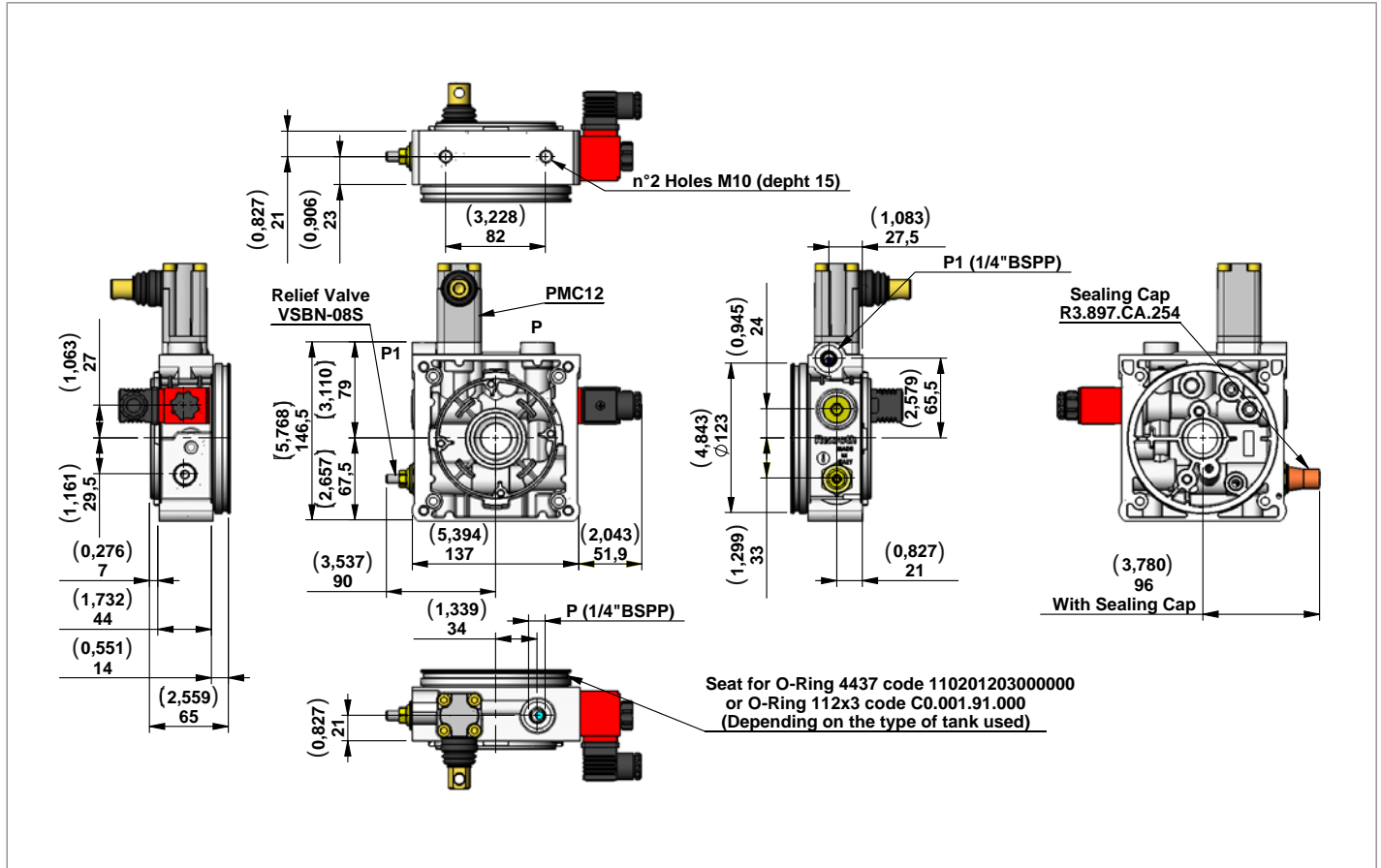

Manifold Code with Relief Valve Pressure Range	Pressure Range bar (psi)	Type	Material Number
M05/05	10-55 (145-798)	205A000	R930052199
M05/10	35-100 (508-1450)	205B000	R930052200
M05/20	90-250 (1305-3626)	205C000	R930052201
M05/35	175-345 (2538-5004)	205D000	R930052202

### View Manifold Tank side

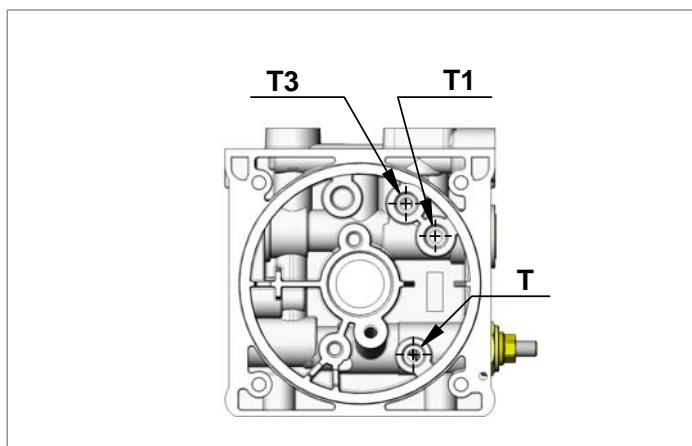

### Manifold Hydraulic Diagram

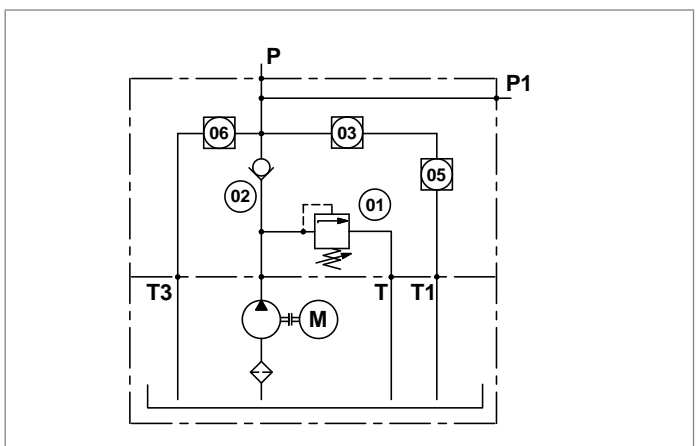



**M05 with valves**

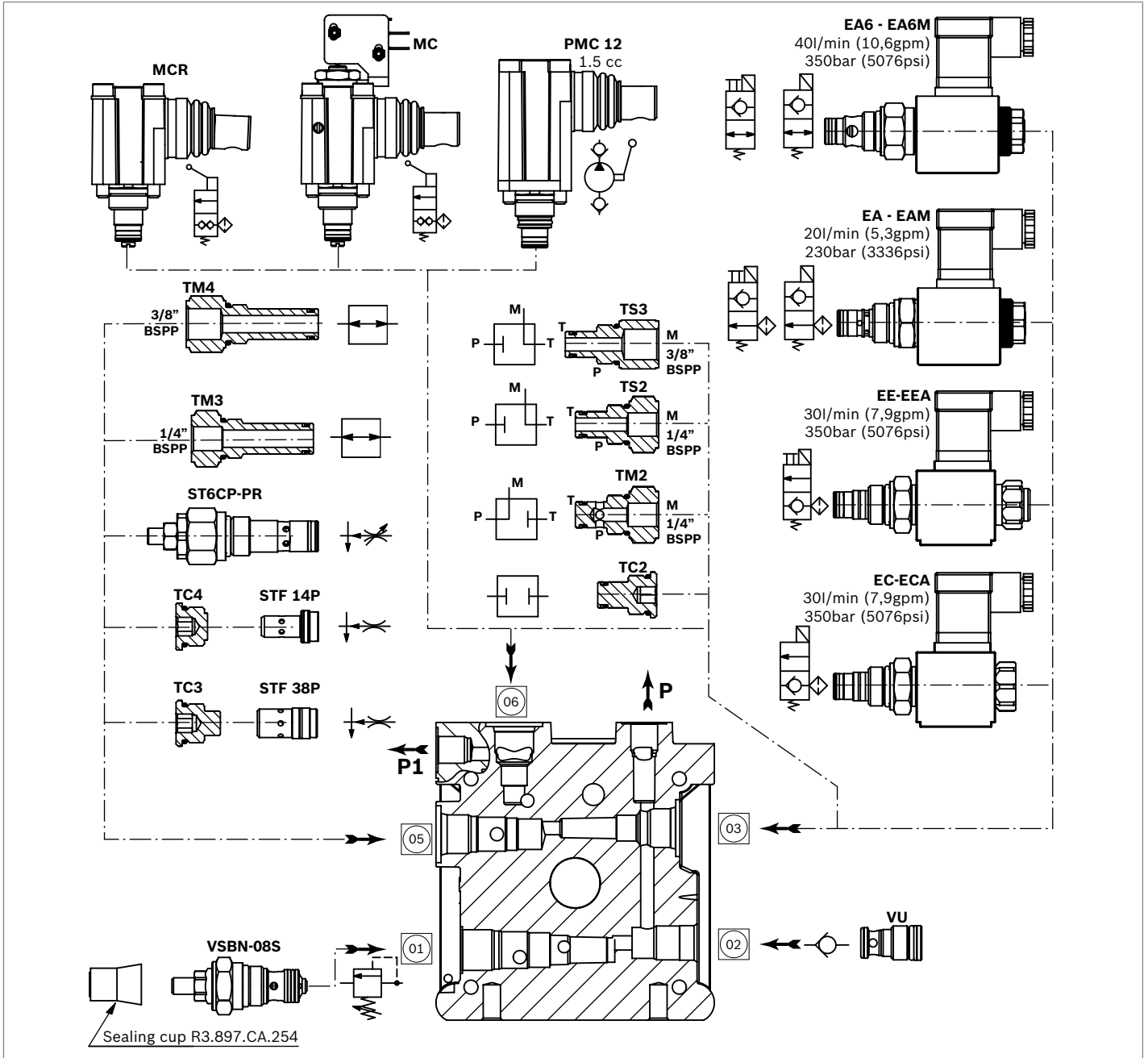

**Main Realizable Diagrams**

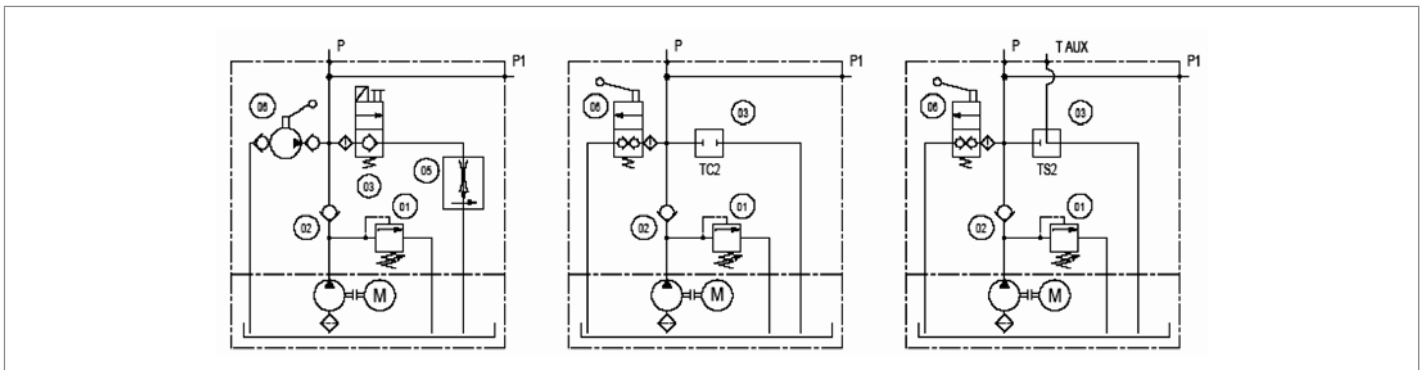

## Central Manifold KE

### M15

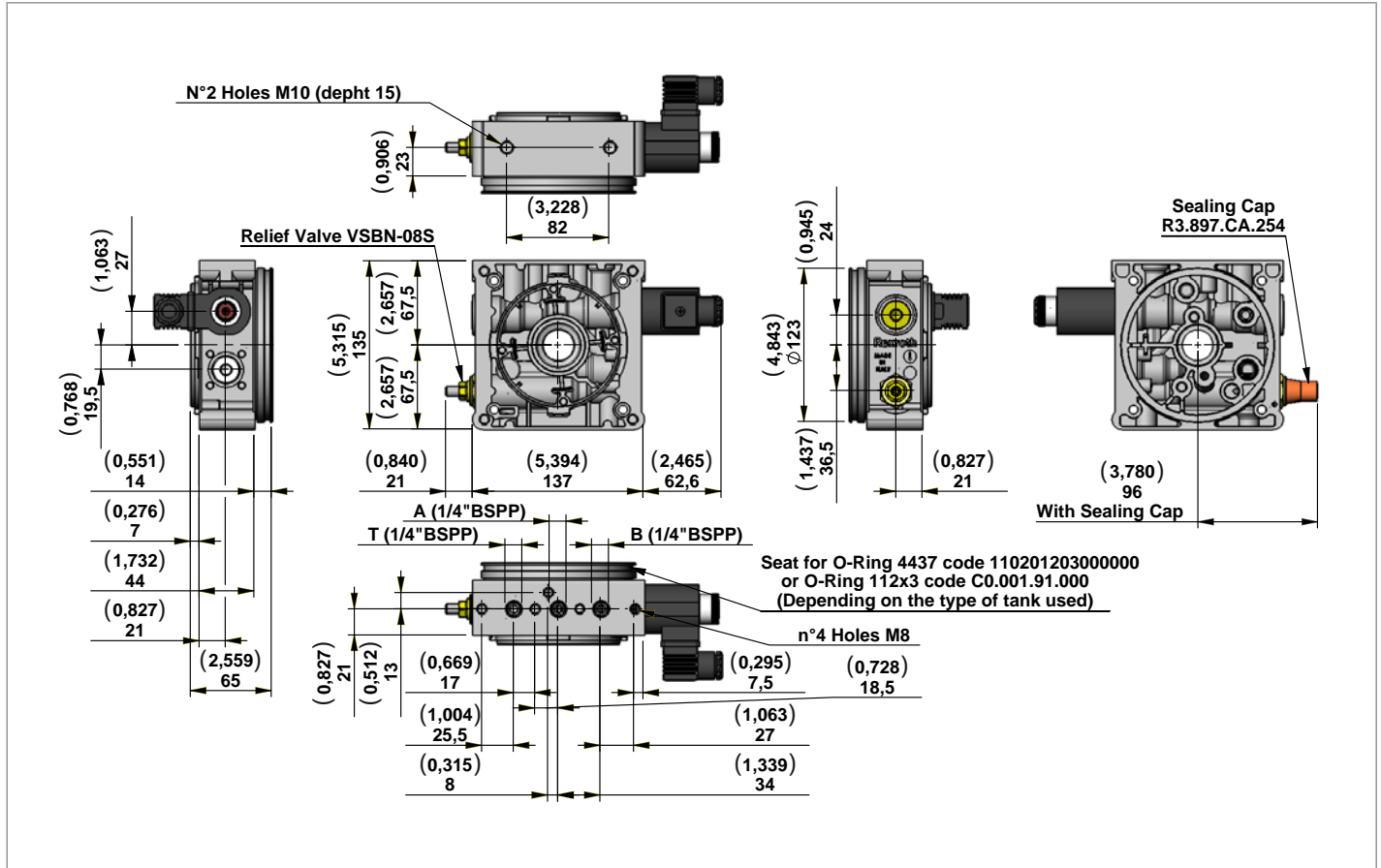

Manifold Code with Relief Valve Pressure Range	Pressure Range bar (psi)	Type	Material Number
<b>M15/05</b>	10-55 (145-798)	215A000	R930052205
<b>M15/10</b>	35-100 (508-1450)	215B000	R930052206
<b>M15/20</b>	90-250 (1305-3626)	215C000	R930052207
<b>M15/35</b>	175-345 (2538-5004)	215D000	R930052208

### View Manifold Tank side

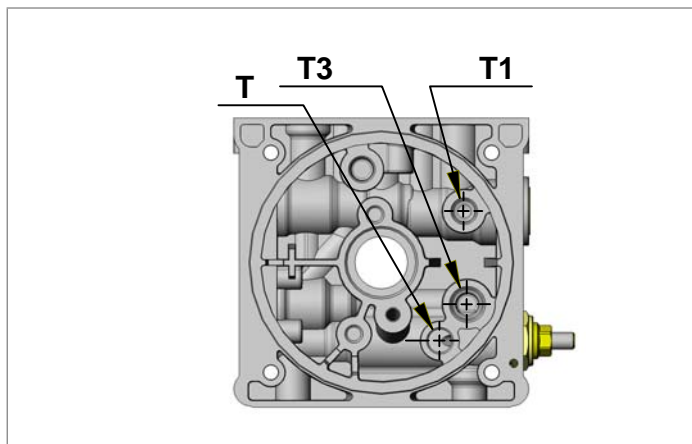

### Manifold Hydraulic Diagram

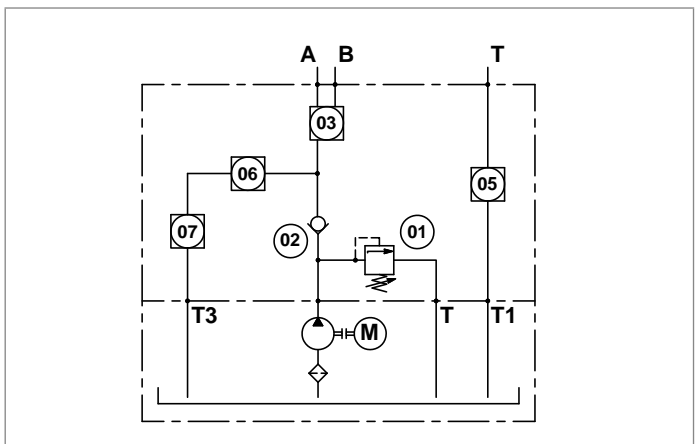

**M15 with valves**

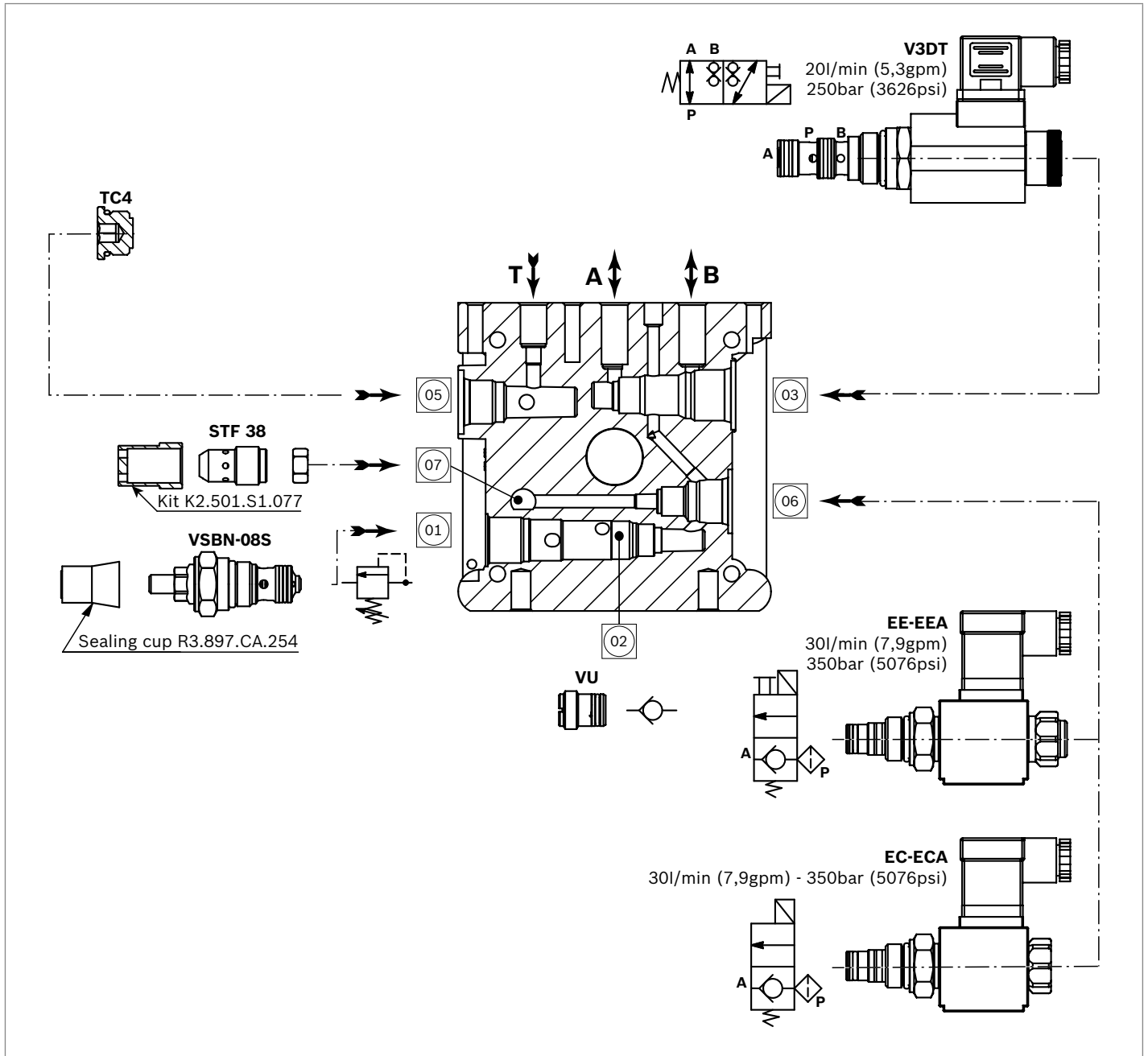

**Main Realizable Diagrams**

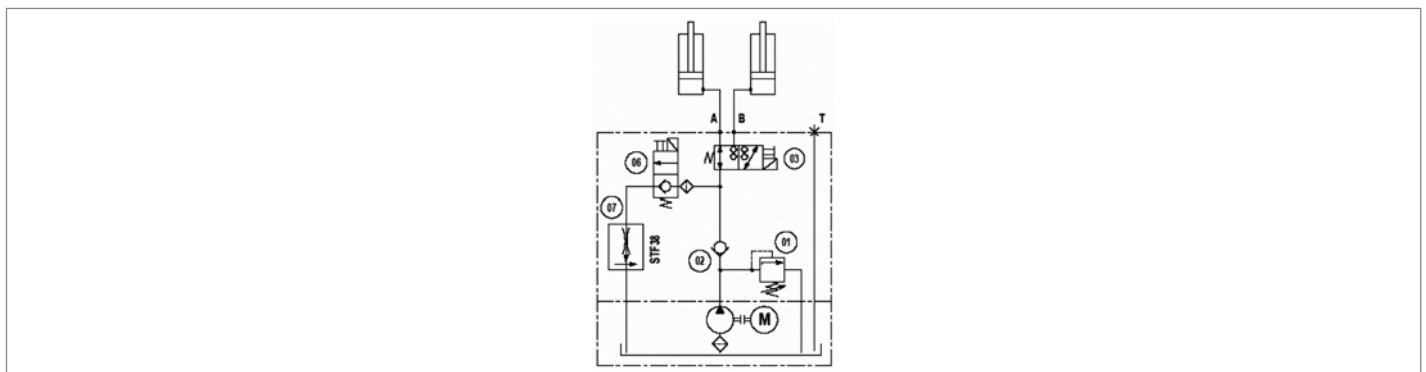

## Central Manifold KE

### M16

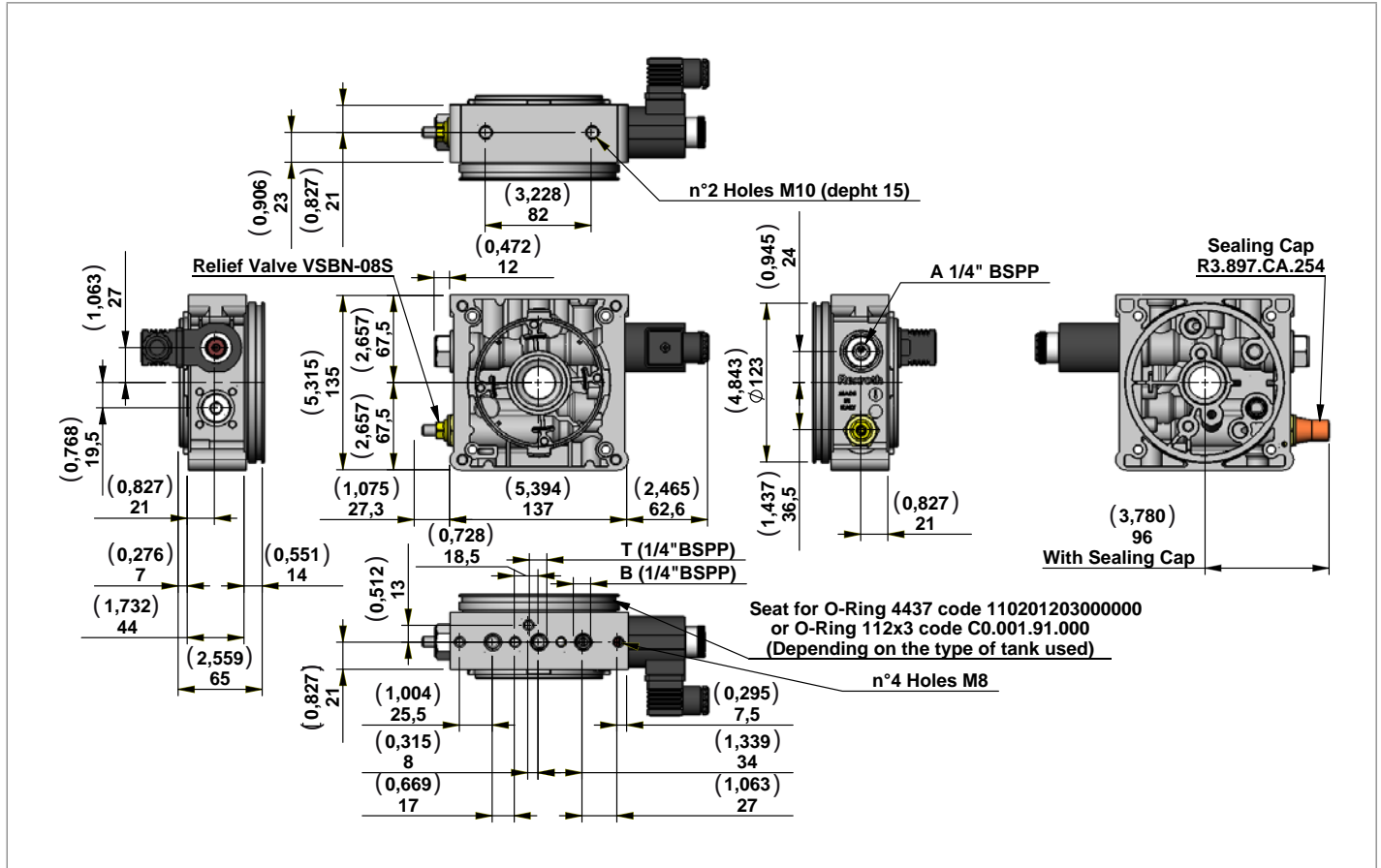

Manifold Code with Relief Valve Pressure Range	Pressure Range bar (psi)	Type	Material Number
<b>M16/05</b>	10-55 (145-798)	216A000	R930052212
<b>M16/10</b>	35-100 (508-1450)	216B000	R930052213
<b>M16/20</b>	90-250 (1305-3626)	216C000	R930052214
<b>M16/35</b>	175-345 (2538-5004)	216D000	R930052215

### View Manifold Tank side

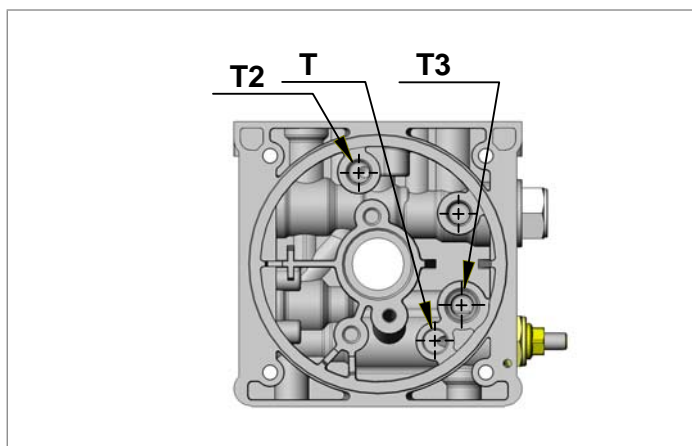

### Manifold Hydraulic Diagram

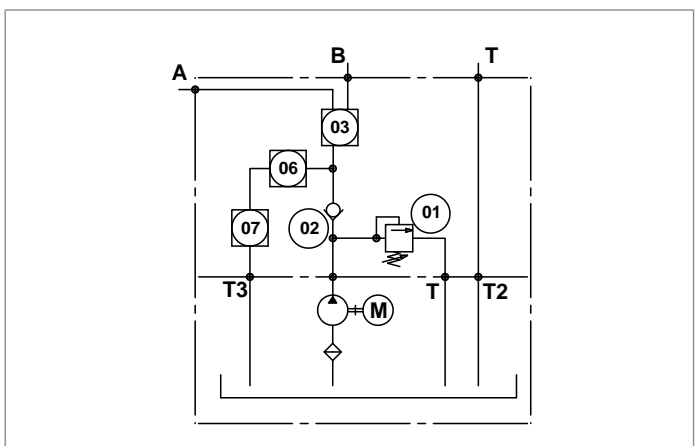

**M16 with valves**

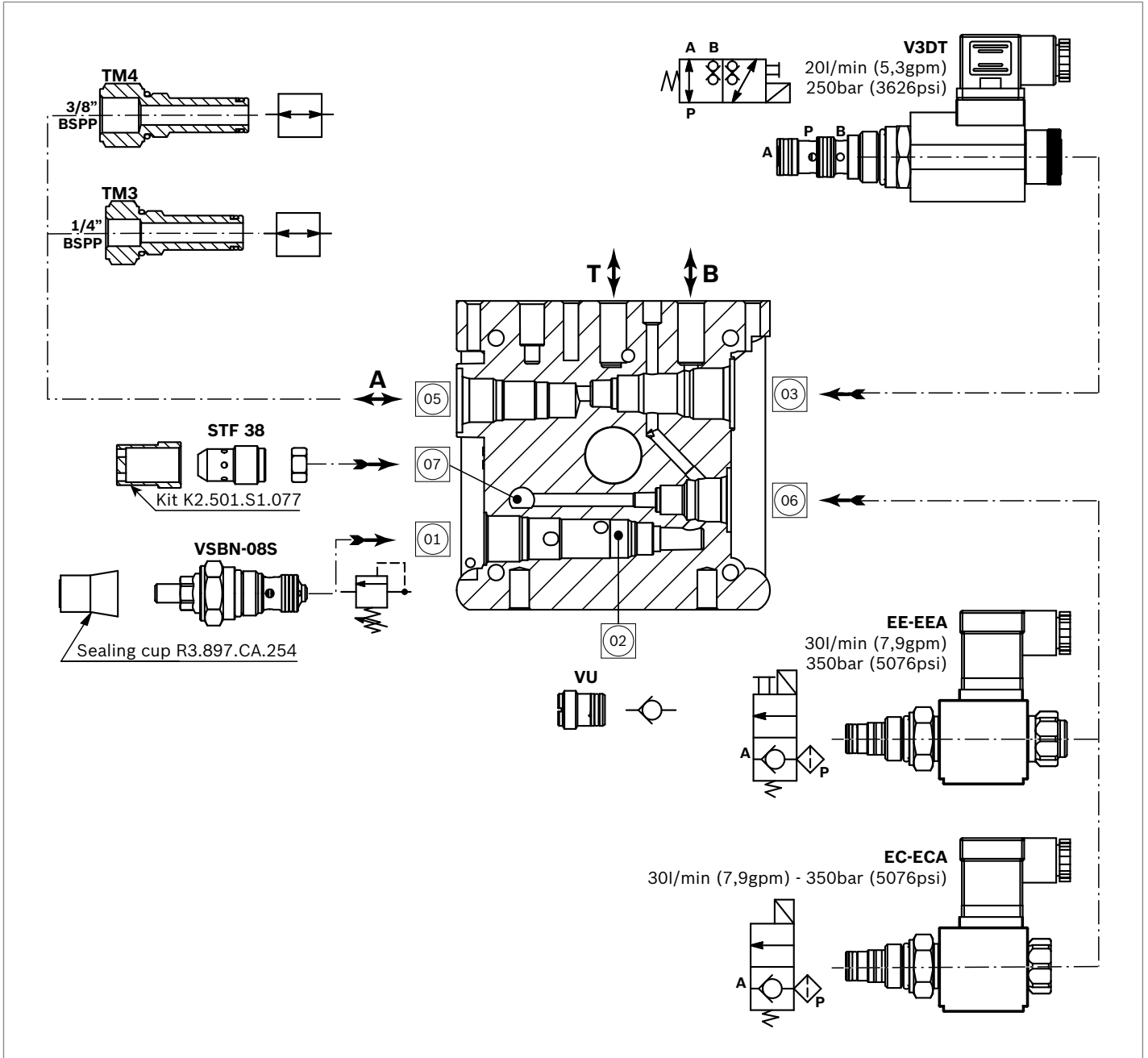

**Main Realizable Diagrams**

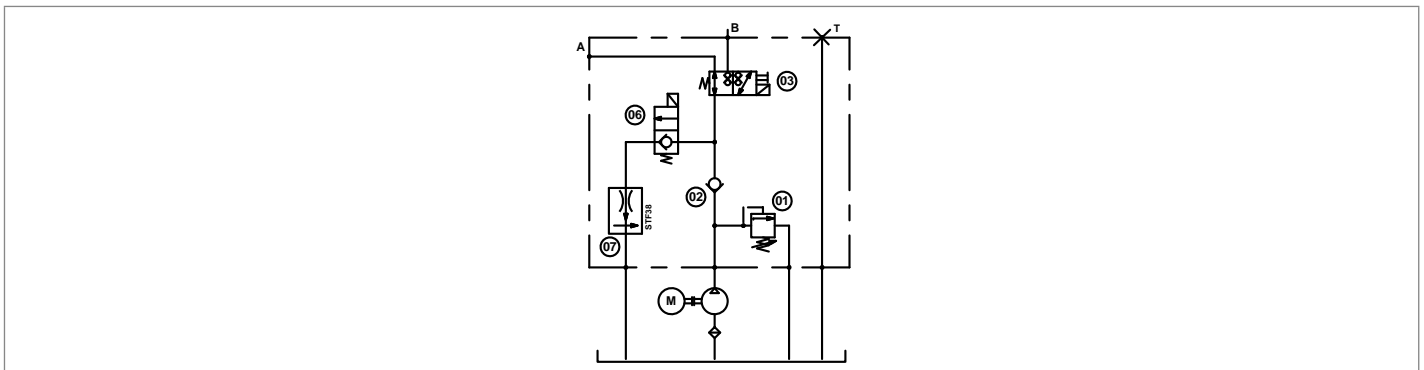

## Central Manifold KE

### M21

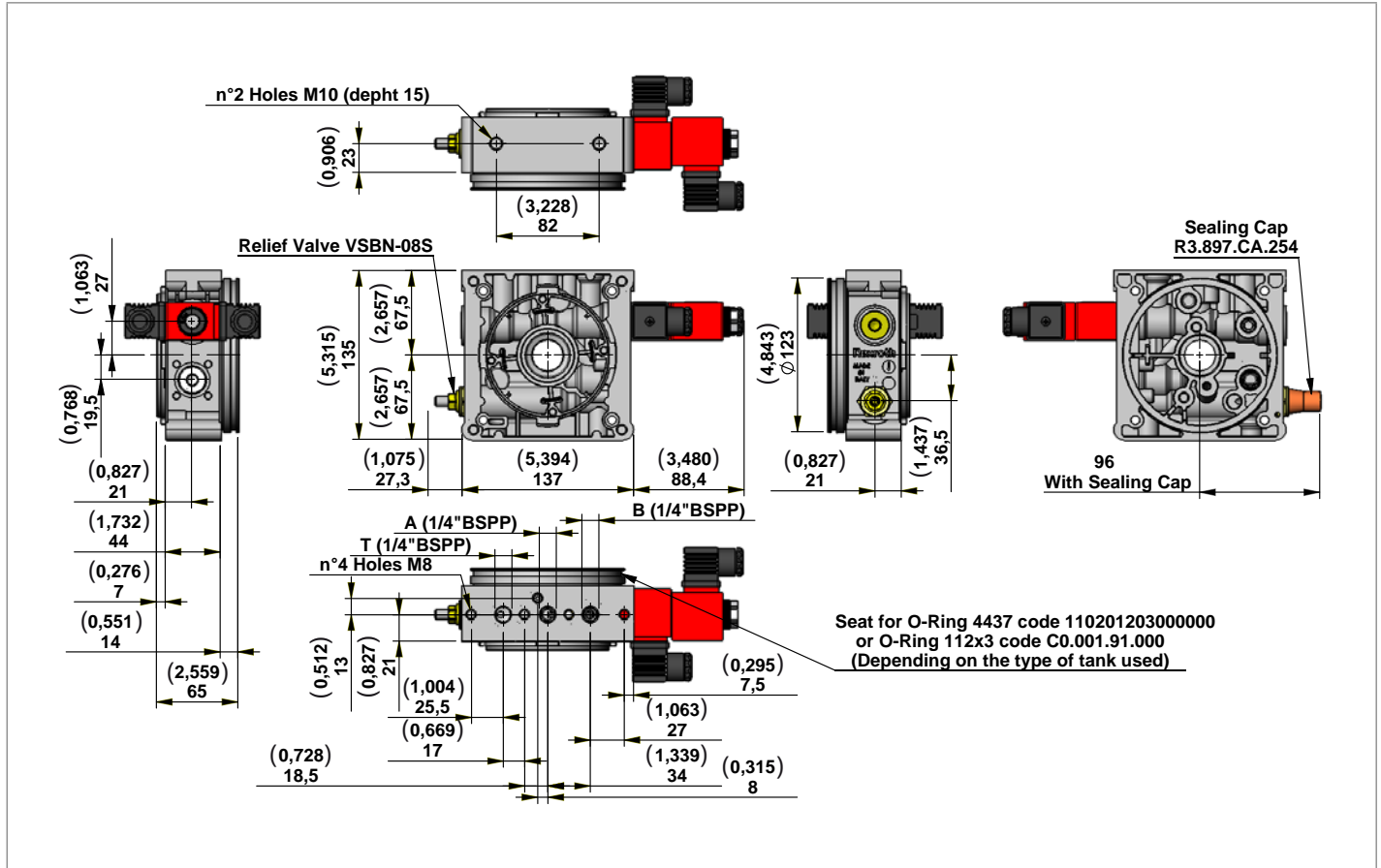

Manifold Code with Relief Valve Pressure Range	Pressure Range bar (psi)	Type	Material Number
<b>M21/05</b>	10-55 (145-798)	221A000	R930052217
<b>M21/10</b>	35-100 (508-1450)	221B000	R930052218
<b>M21/20</b>	90-250 (1305-3626)	221C000	R930052219
<b>M21/35</b>	175-345 (2538-5004)	221D000	R930052220

### View Manifold Tank side

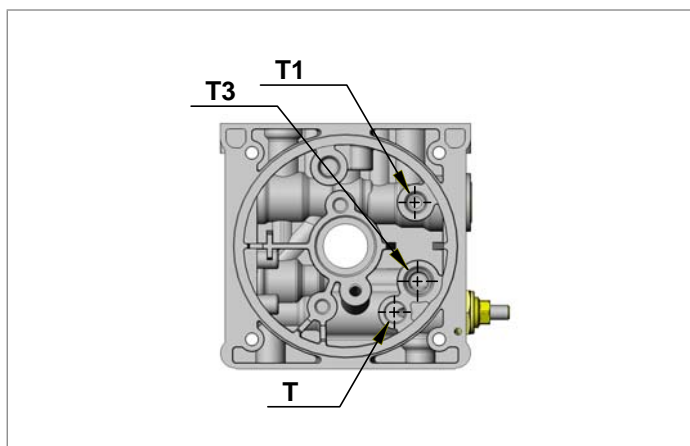

### Manifold Hydraulic Diagram

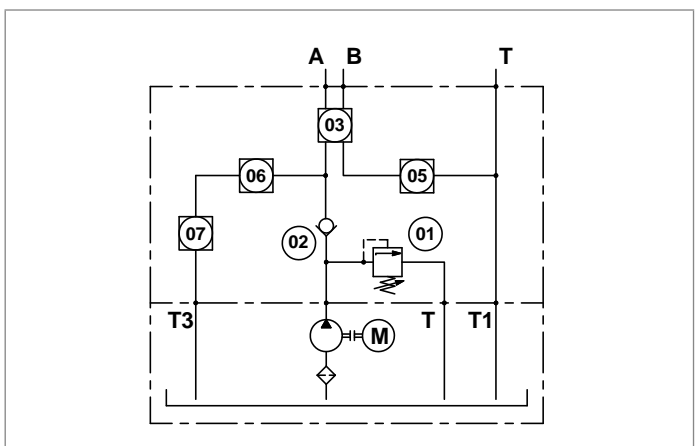

**M21 with valves**

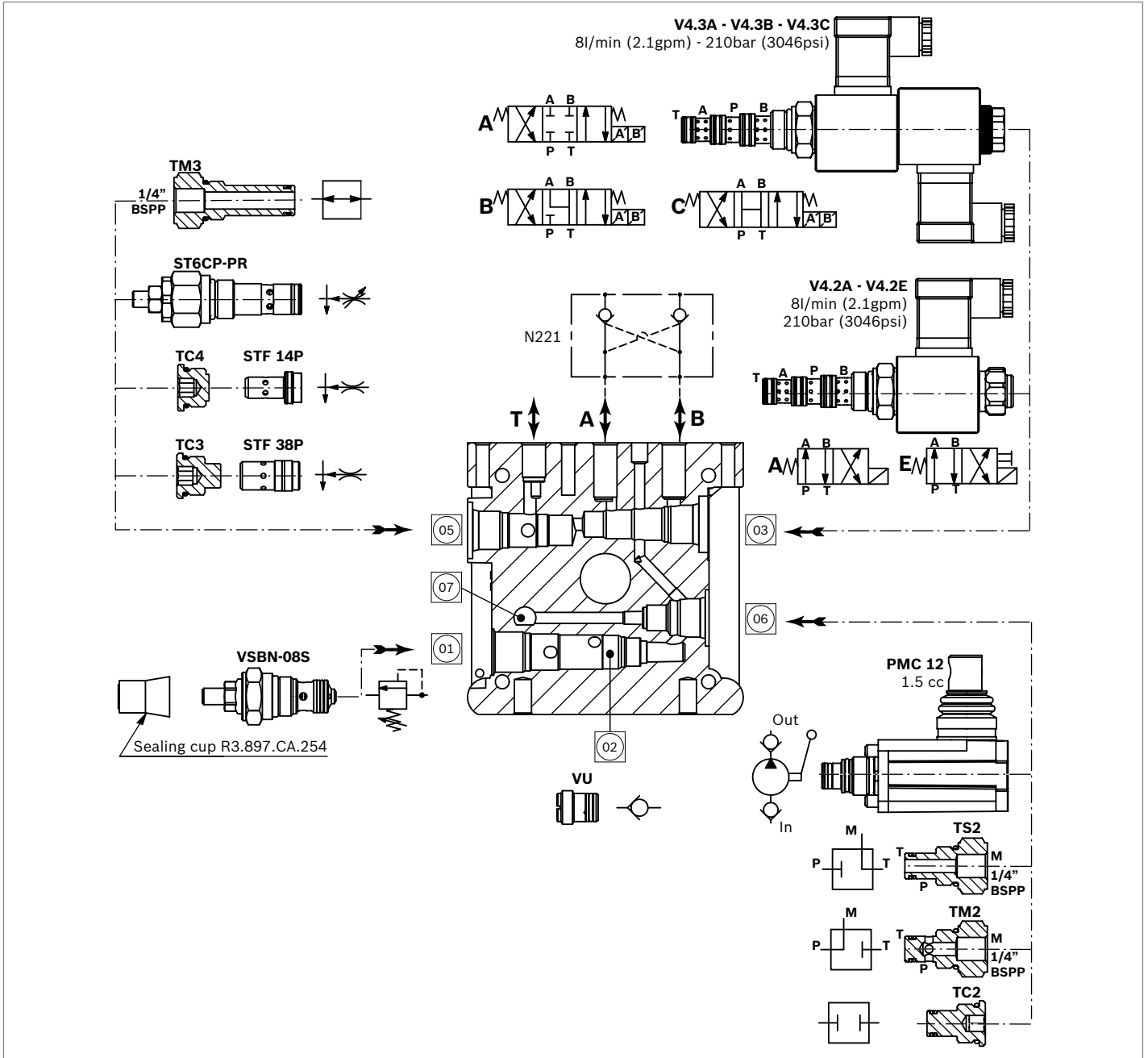

**Main Realizable Diagrams**

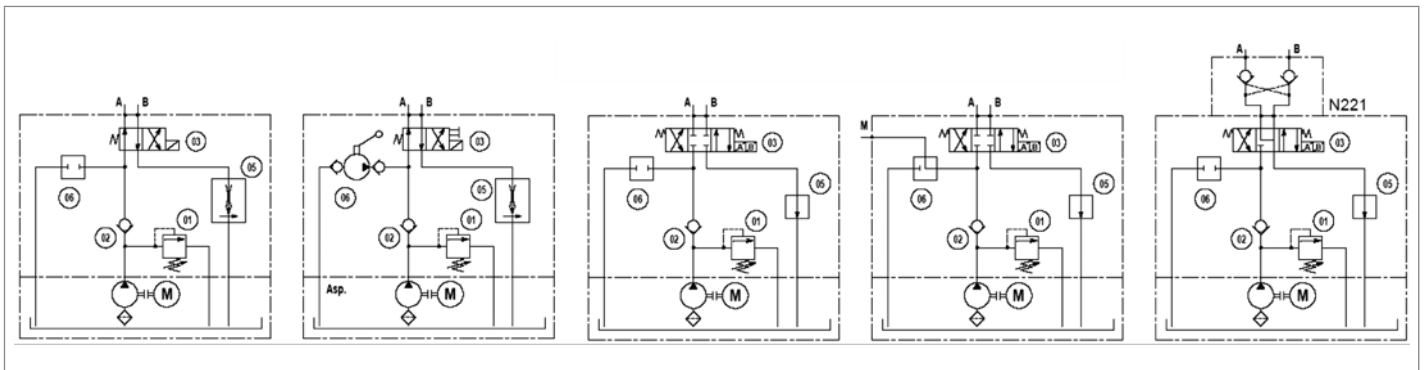

## Central Manifold KE

### M25

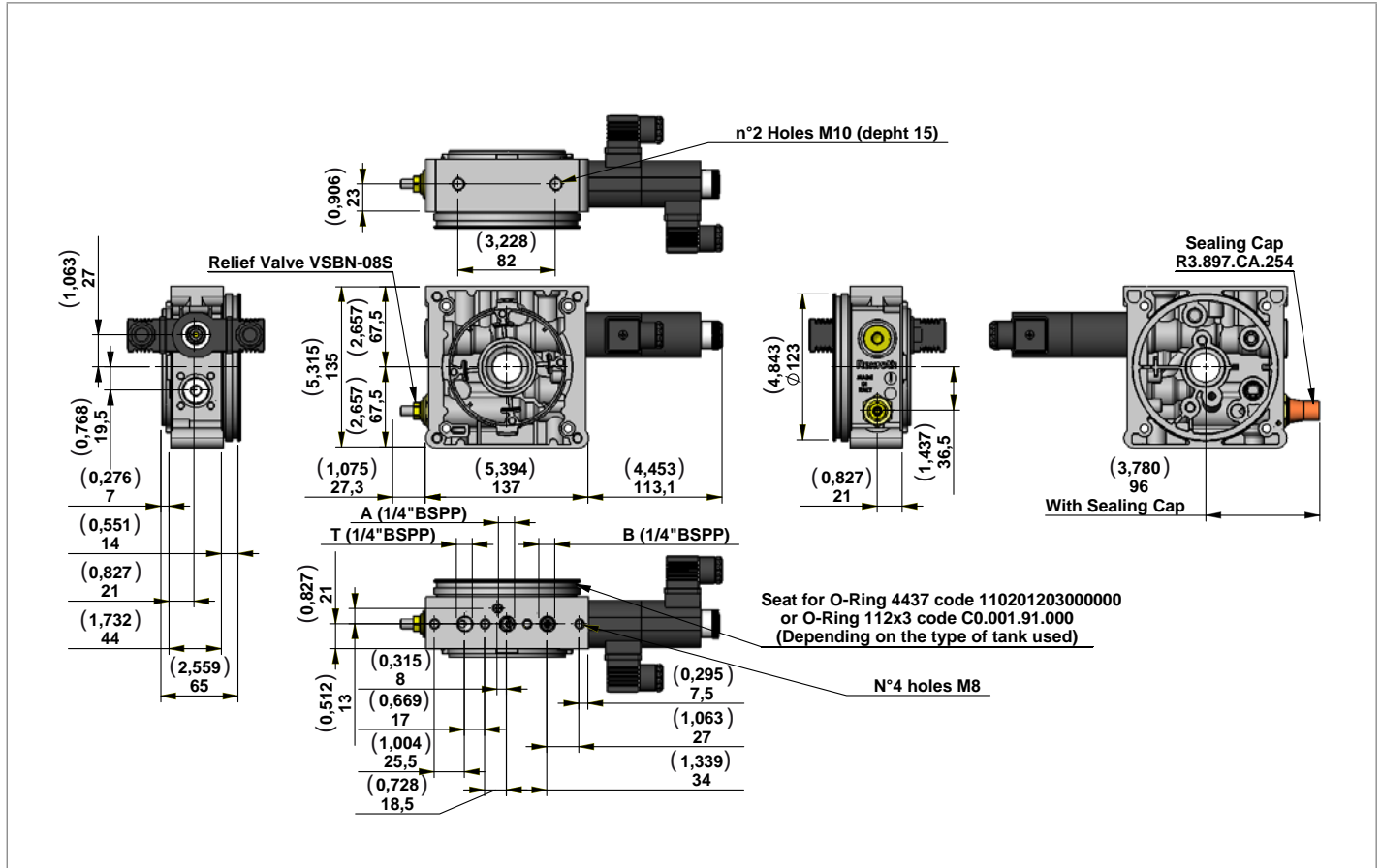

Manifold Code with Relief Valve Pressure Range	Pressure Range bar (psi)	Type	Material Number
M25/05	10-55 (145-798)	225A000	R930052221
M25/10	35-100 (508-1450)	225B000	R930052222
M25/20	90-250 (1305-3626)	225C000	R930052223
M25/35	175-345 (2538-5004)	225D000	R930052224

### View Manifold Tank side

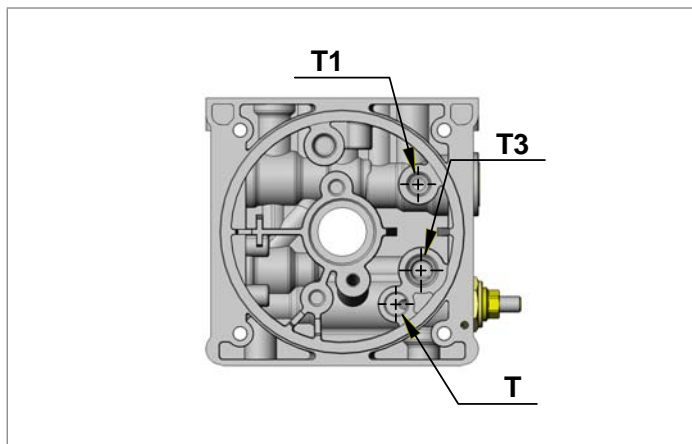

### Manifold Hydraulic Diagram

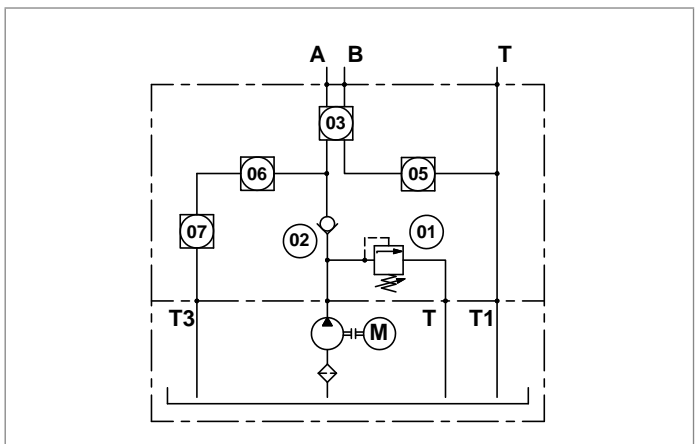



**M25 with valves**

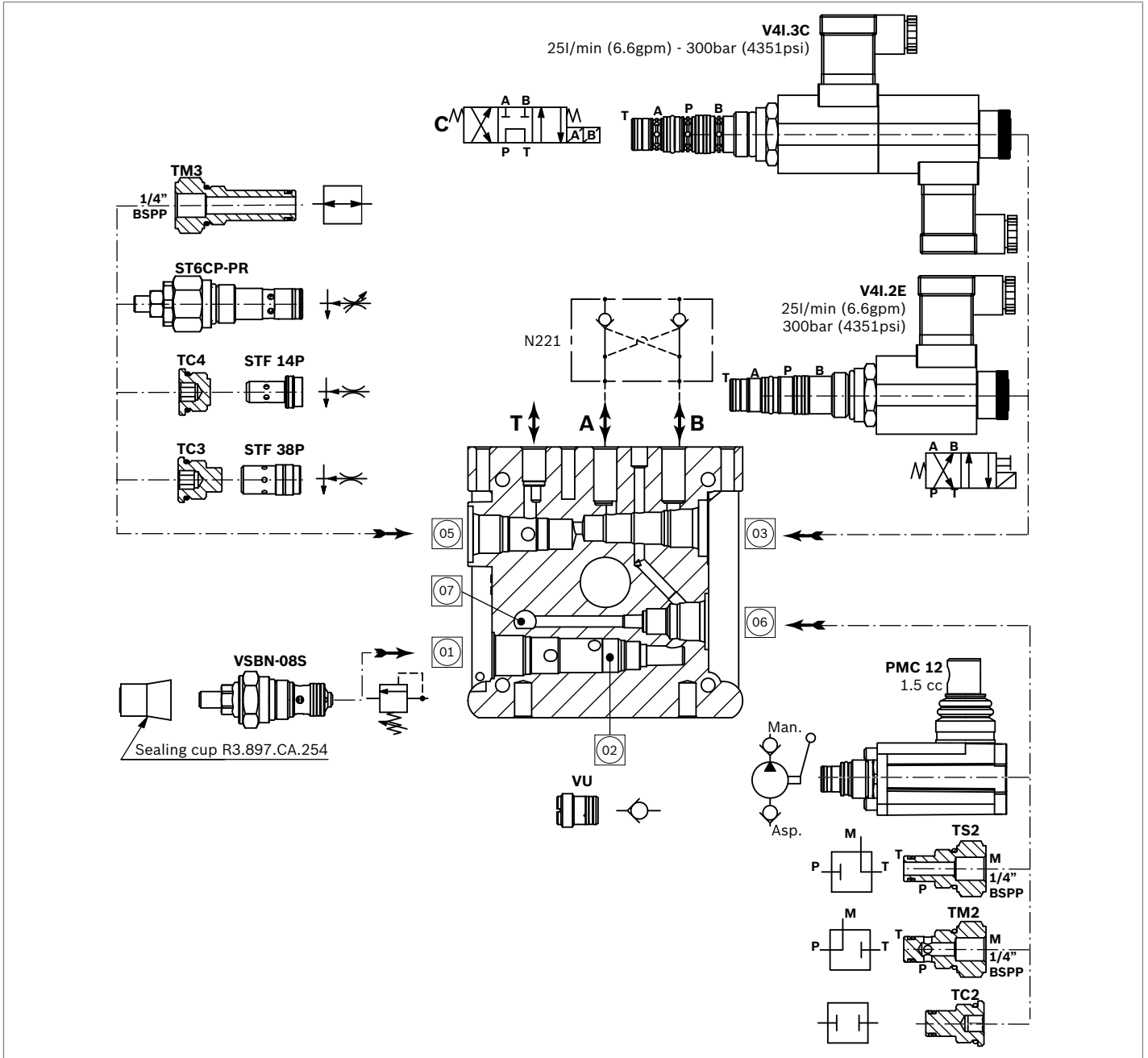

**Main Realizable Diagrams**

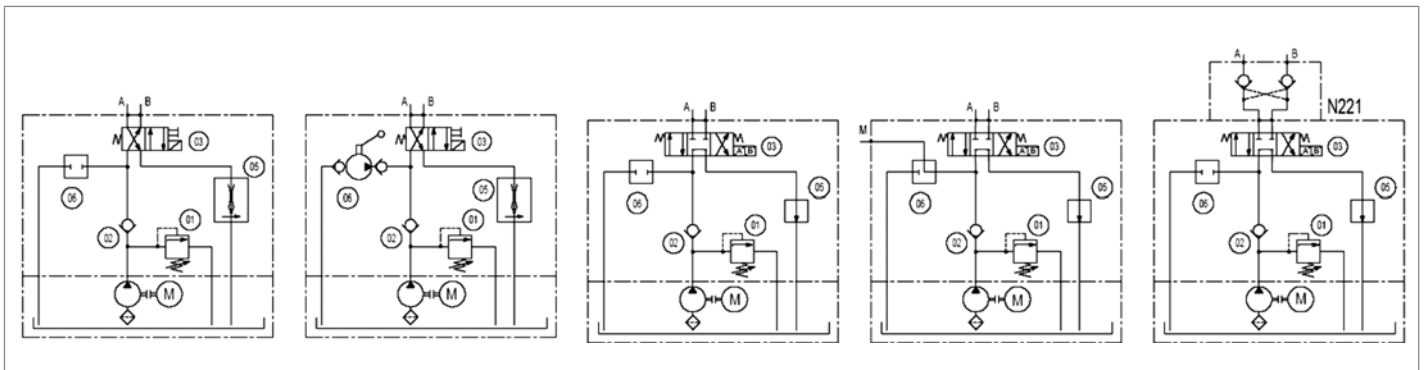

## Central Manifold KE

### M32

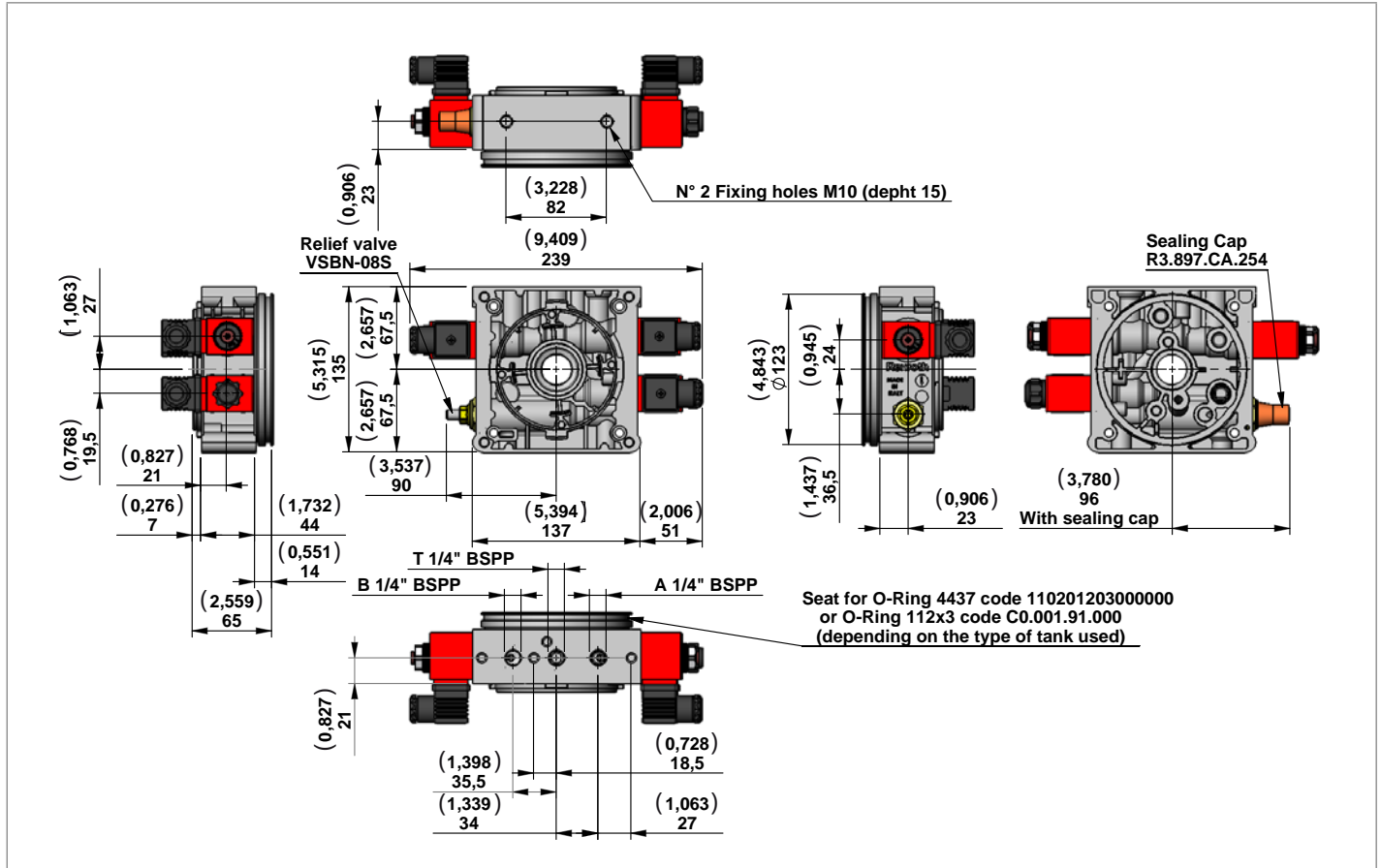

Manifold Code with Relief Valve Pressure Range	Pressure Range bar (psi)	Type	Material Number
M32/10	35-100 (508-1450)	232B000	R930052413
M32/20	90-250 (1305-3626)	232C000	R930052414
M32/35	175-345 (2538-5004)	232D000	R930052415

### View Manifold Tank side

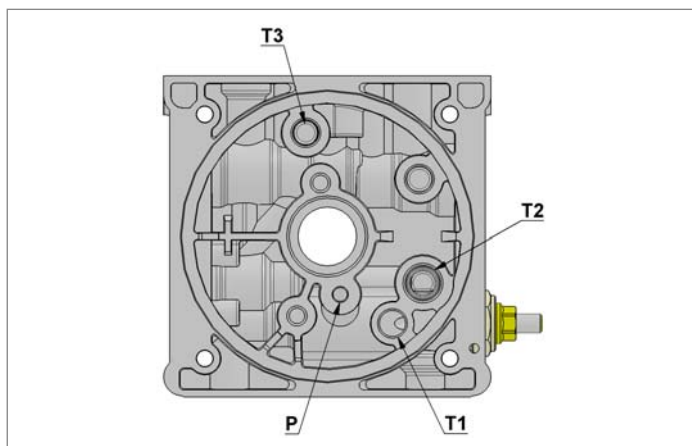

### Manifold Hydraulic Diagram

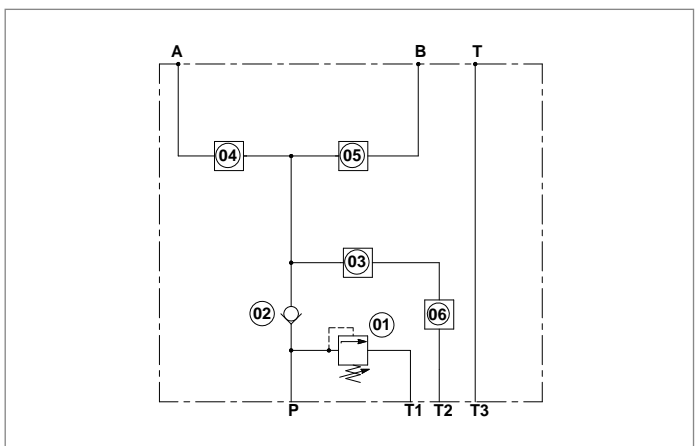

**M32 with valves**

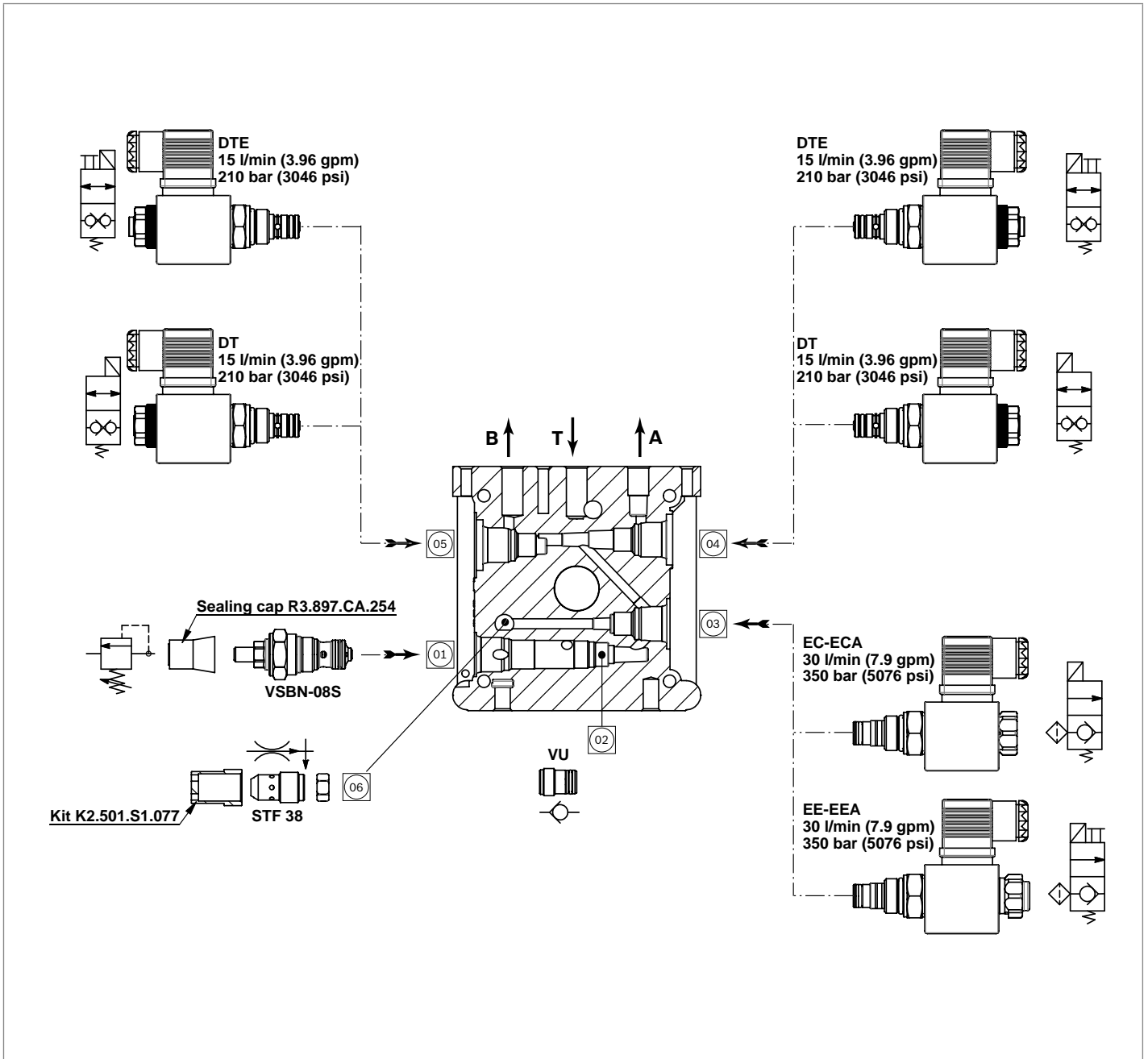

**Main Realizable Diagrams**

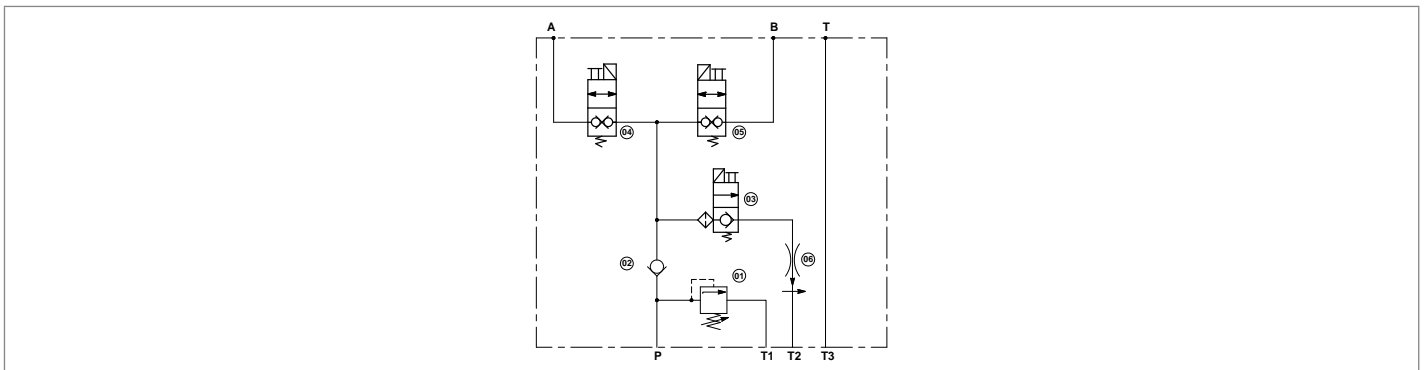

## Central Manifold K

A1

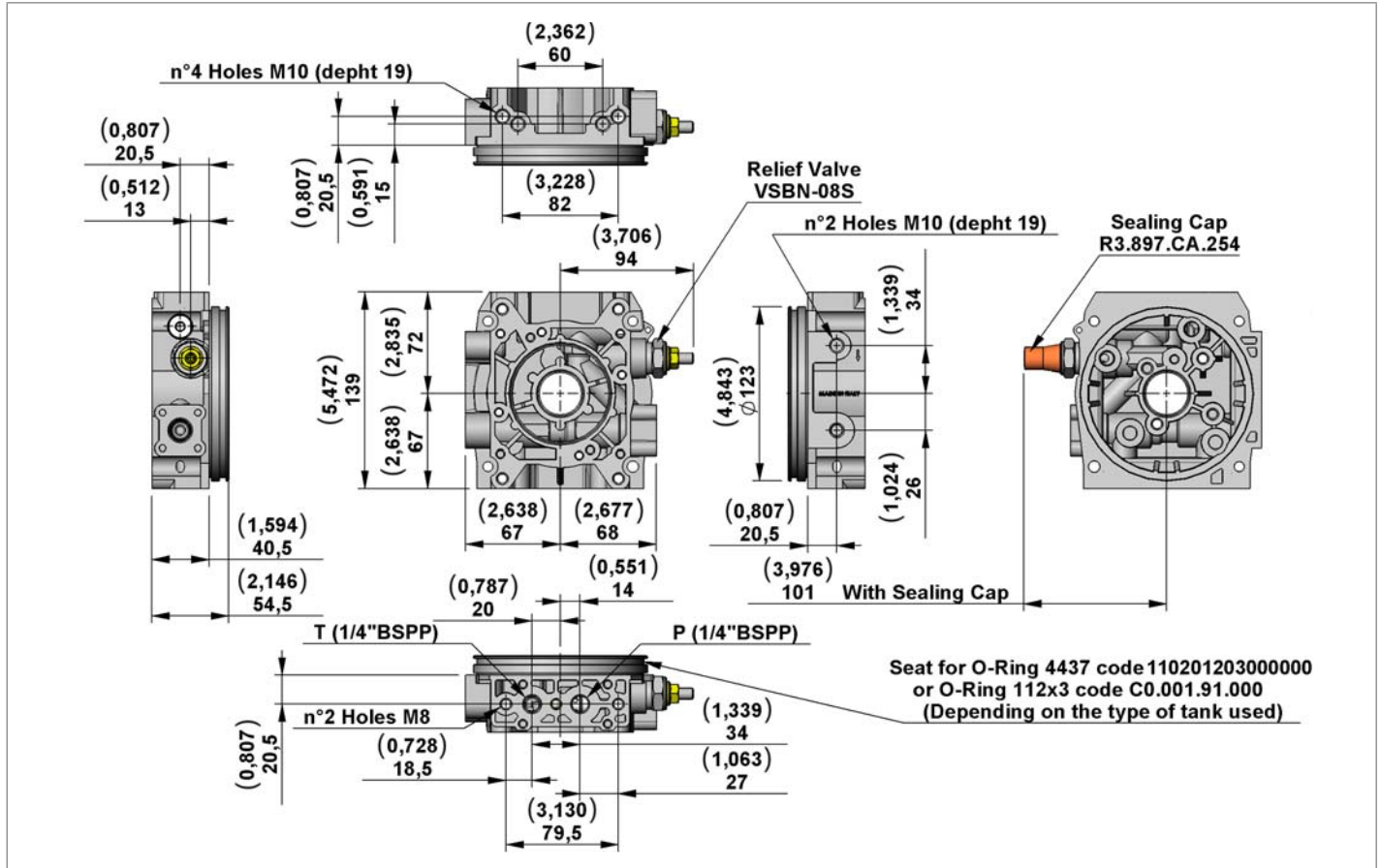

Manifold Code with Relief Valve Pressure Range	Pressure Range bar (psi)	Type	Material Number
A1/05	10-55 (145-798)	101A000A	R930052170
A1/10	35-100 (508-1450)	101B000A	R930052171
A1/20	90-250 (1305-3626)	101C000	R932008681
A1/35	175-345 (2538-5004)	101D000	R932008682

View Manifold Tank side

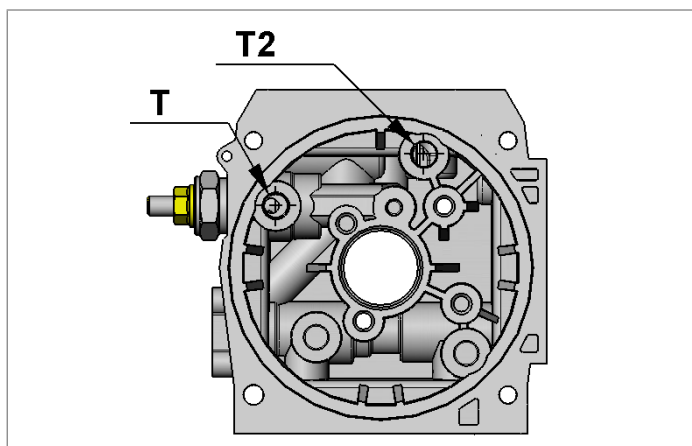

Manifold Hydraulic Diagram

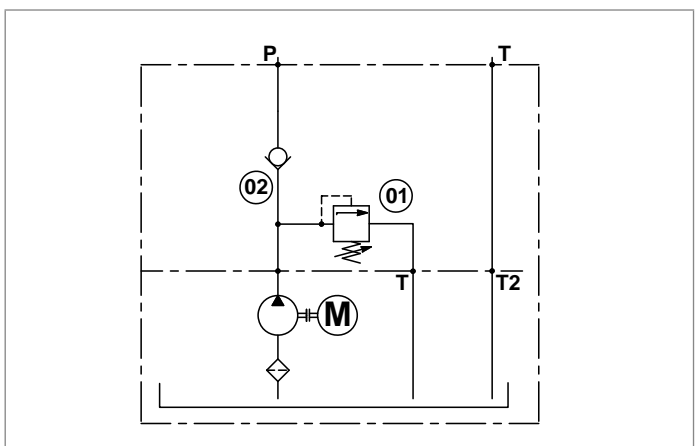

**A1 with valves**

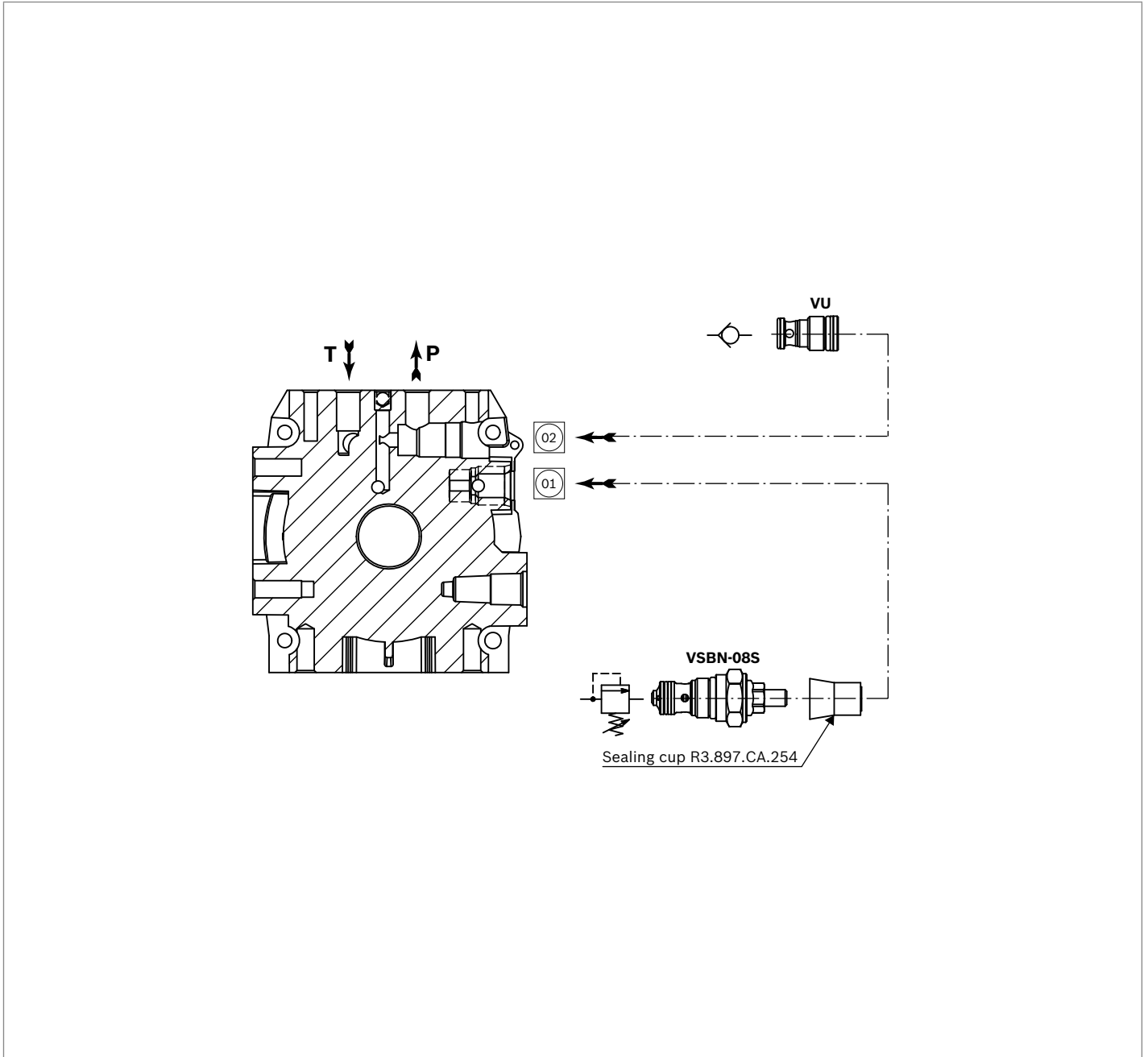

## Central Manifold K

### A12

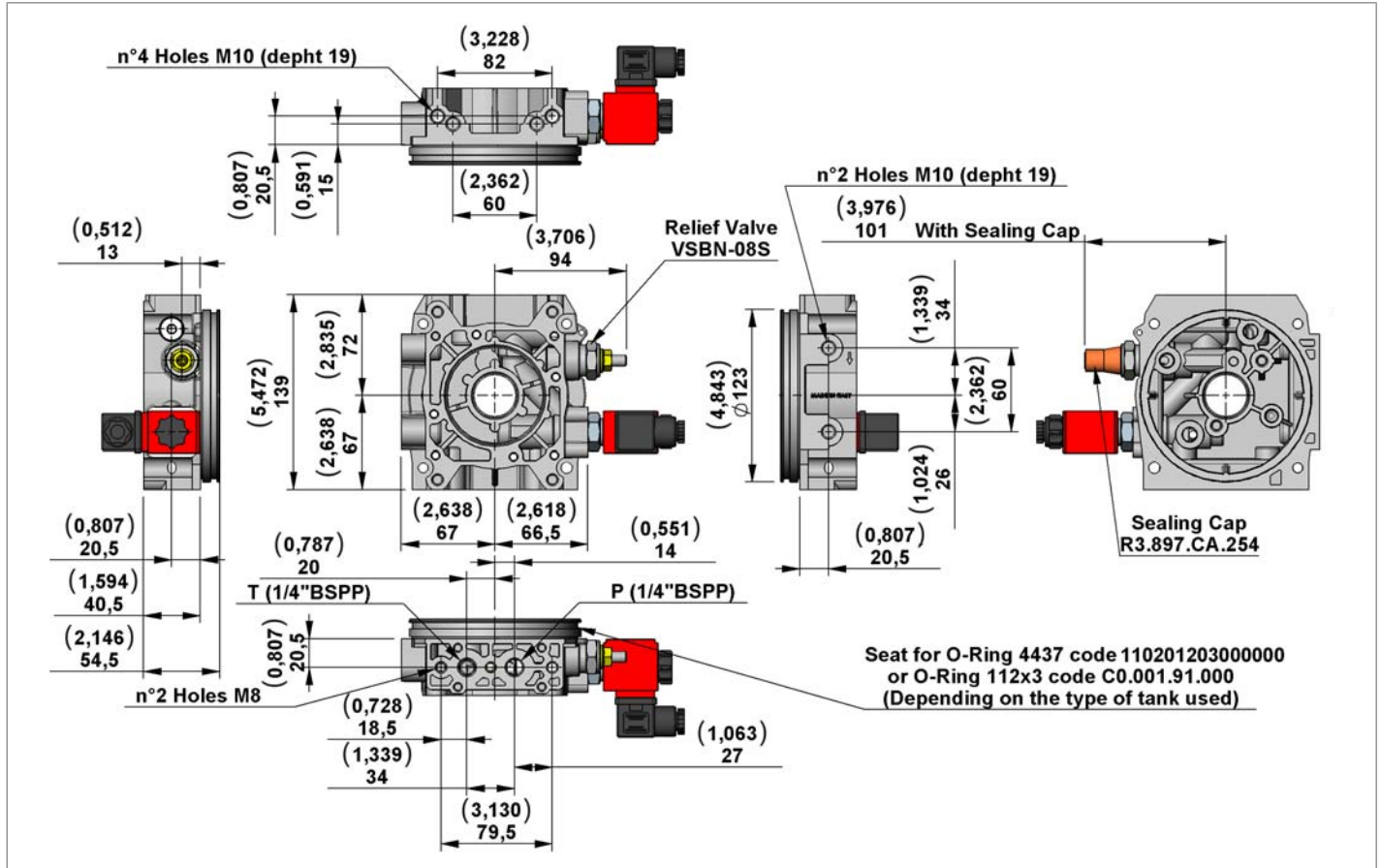

Manifold Code with Relief Valve Pressure Range	Pressure Range bar (psi)	Type	Material Number
A12/05	10-55 (145-798)	112A000A	R930052172
A12/10	35-100 (508-1450)	112B000A	R930052173
A12/20	90-250 (1305-3626)	112C000	R932008685
A12/35	175-345 (2538-5004)	112D000	R932008686

### View Manifold Tank side

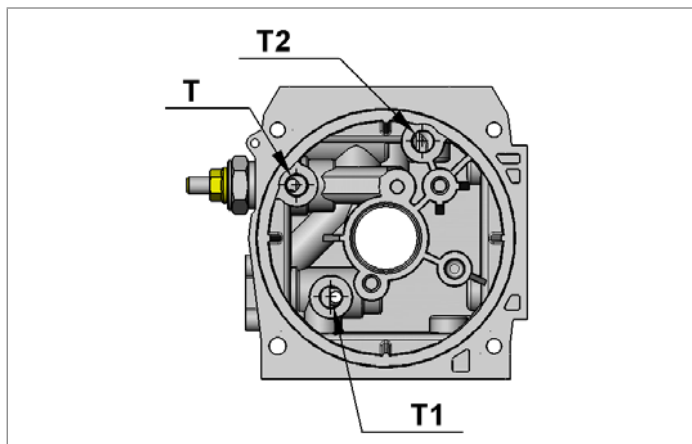

### Manifold Hydraulic Diagram

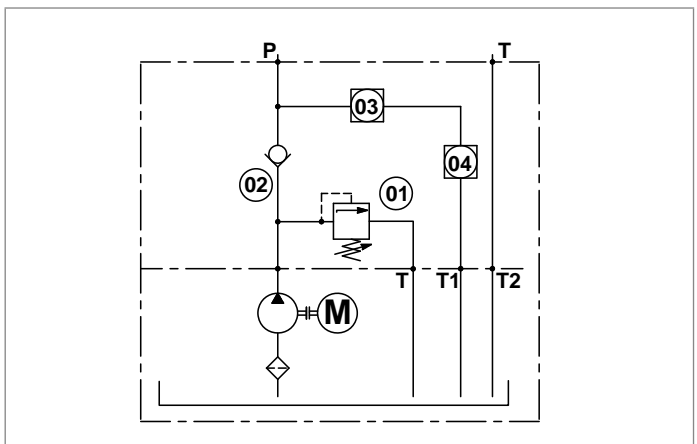

**A12 with valves**

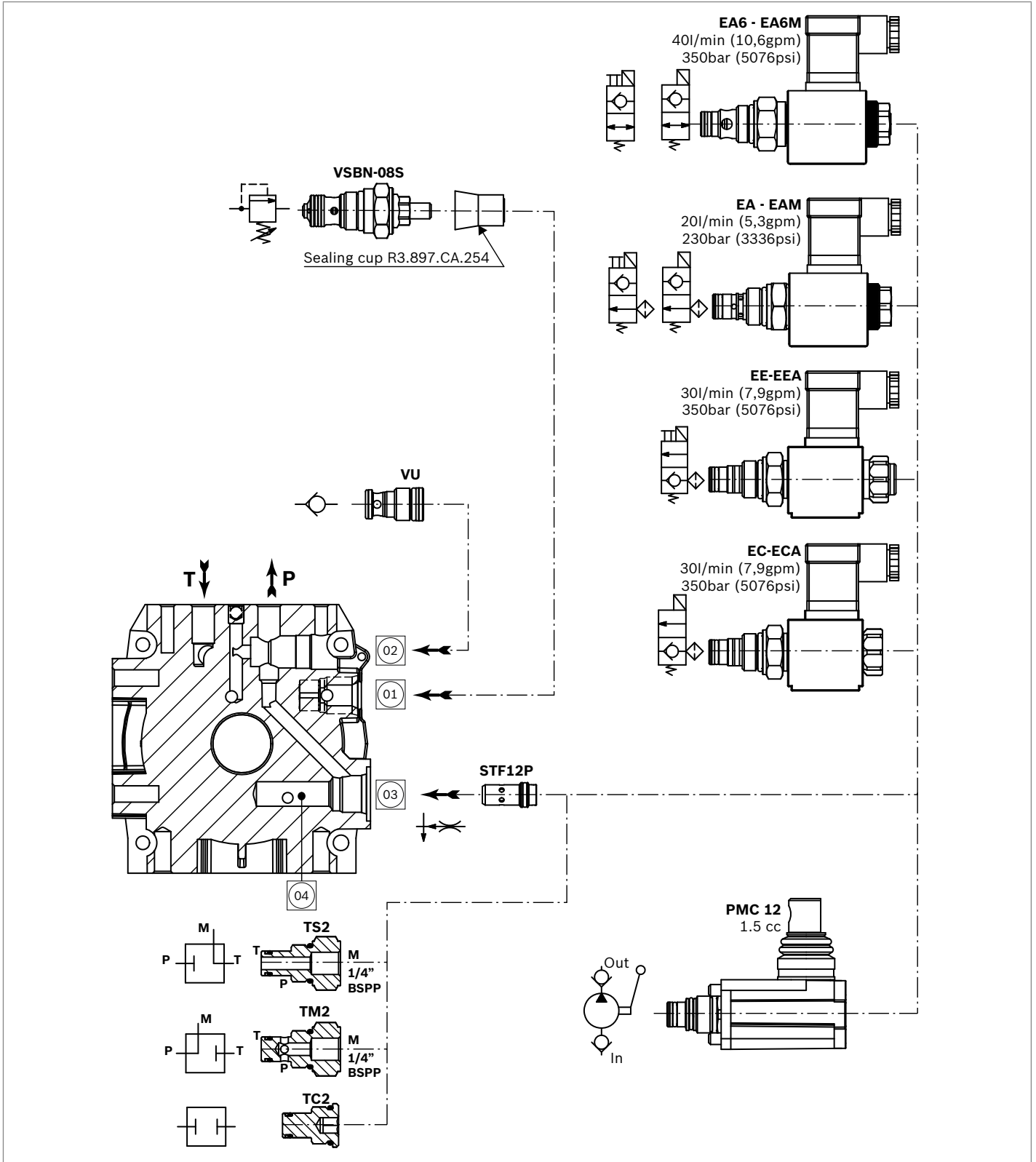

## Central Manifold K

A9

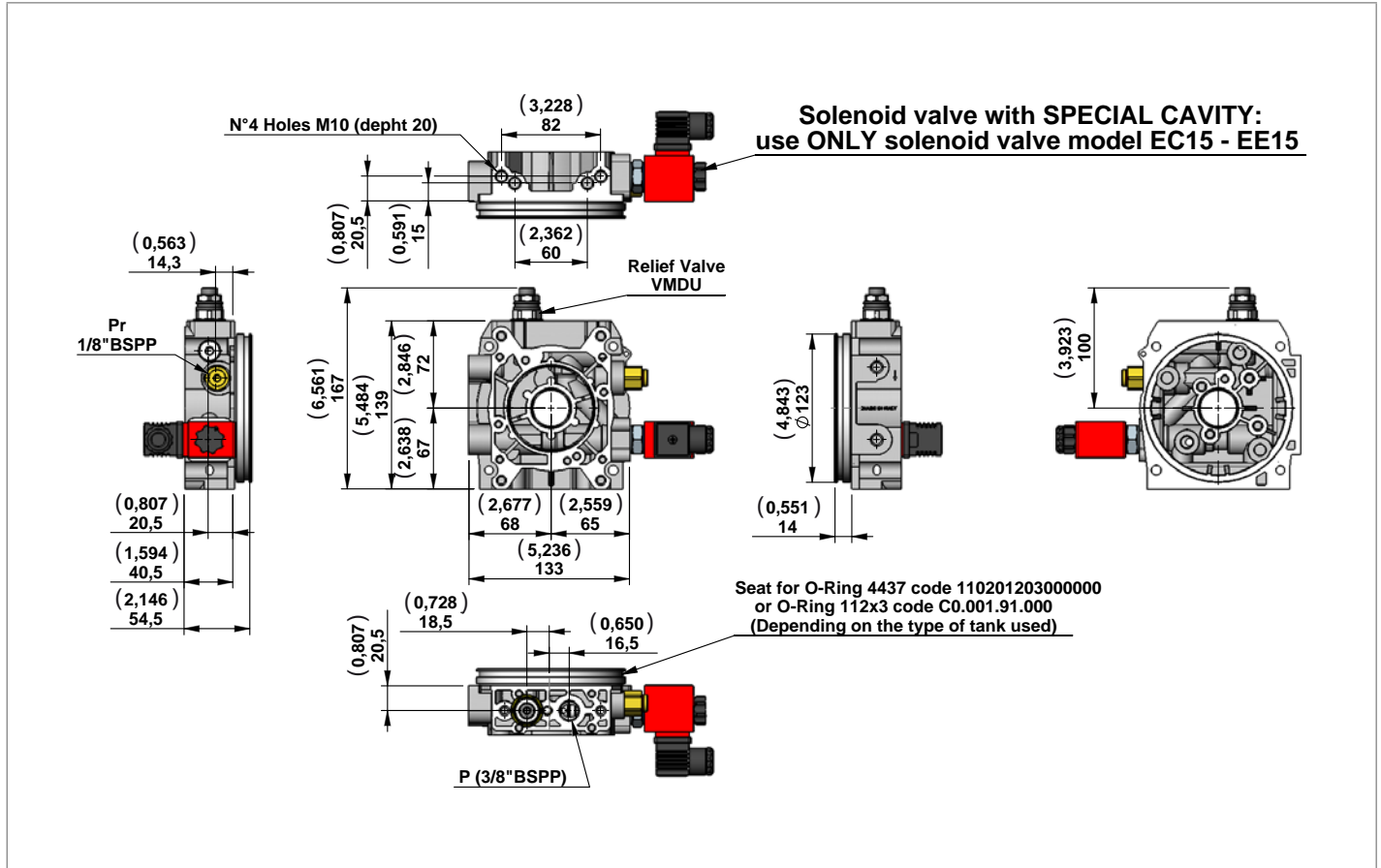

Manifold Code with Relief Valve Pressure Range	Pressure Range bar (psi)	Type	Material Number
A9/20	80-250 (1160-3626)	109H000	R932009128

View Manifold Tank side

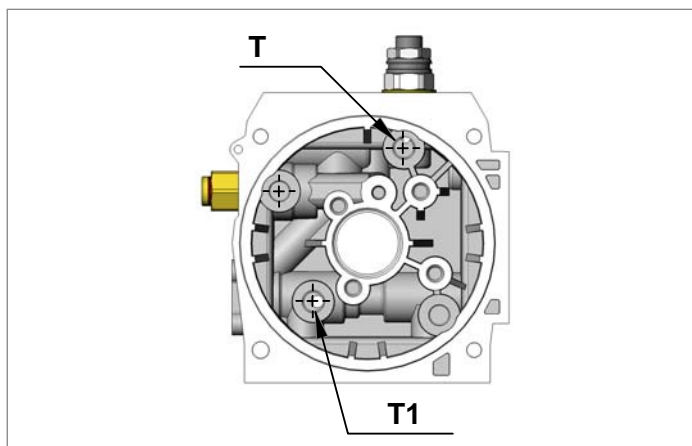

Manifold Hydraulic Diagram

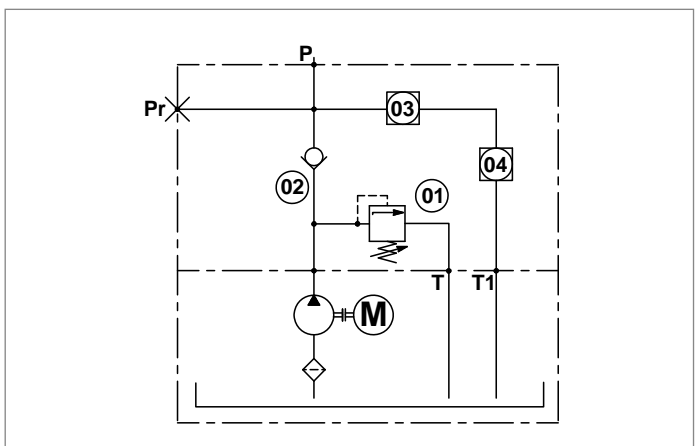



**A9 with valves**

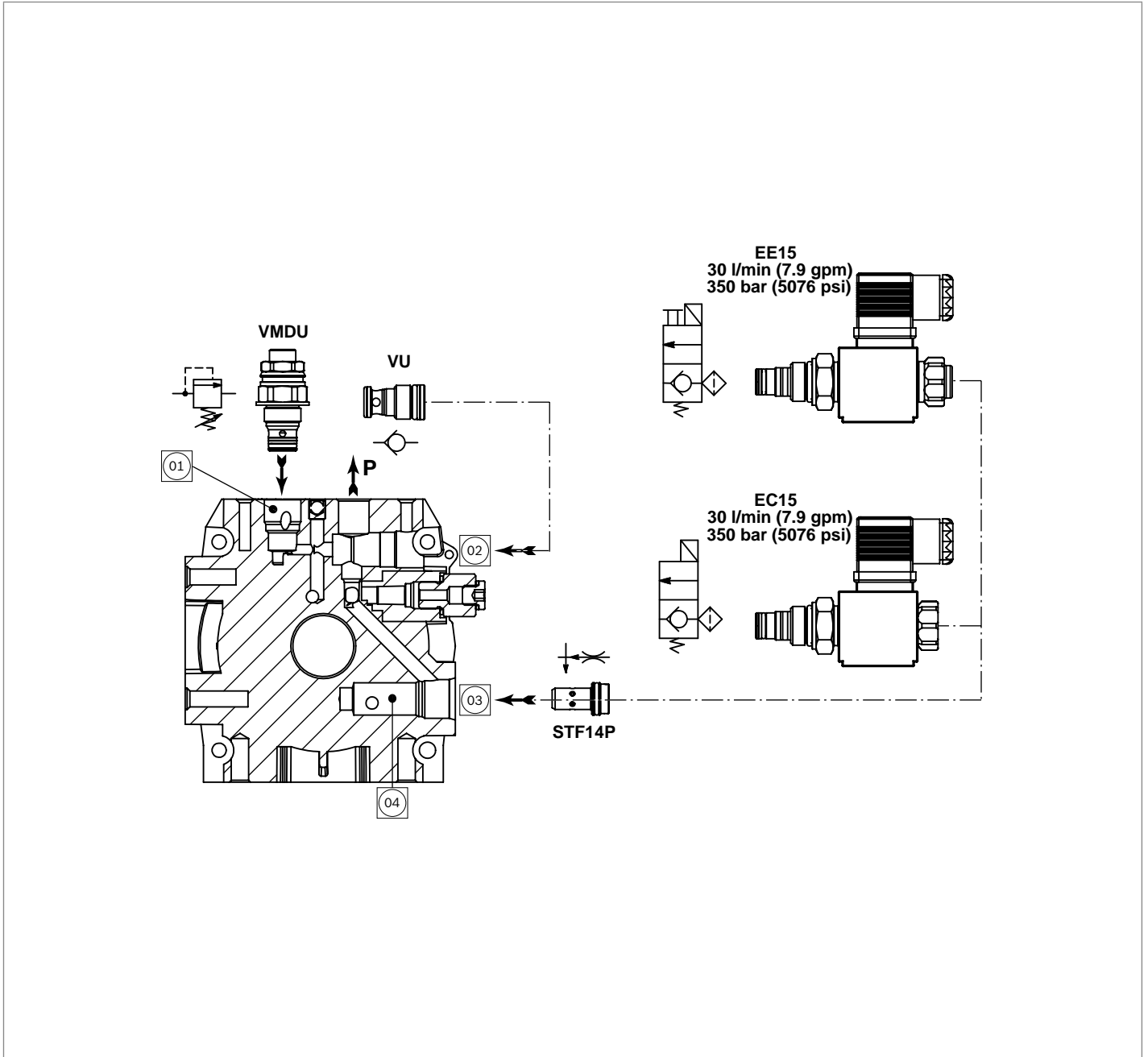

## Central Manifold KS

### KS00

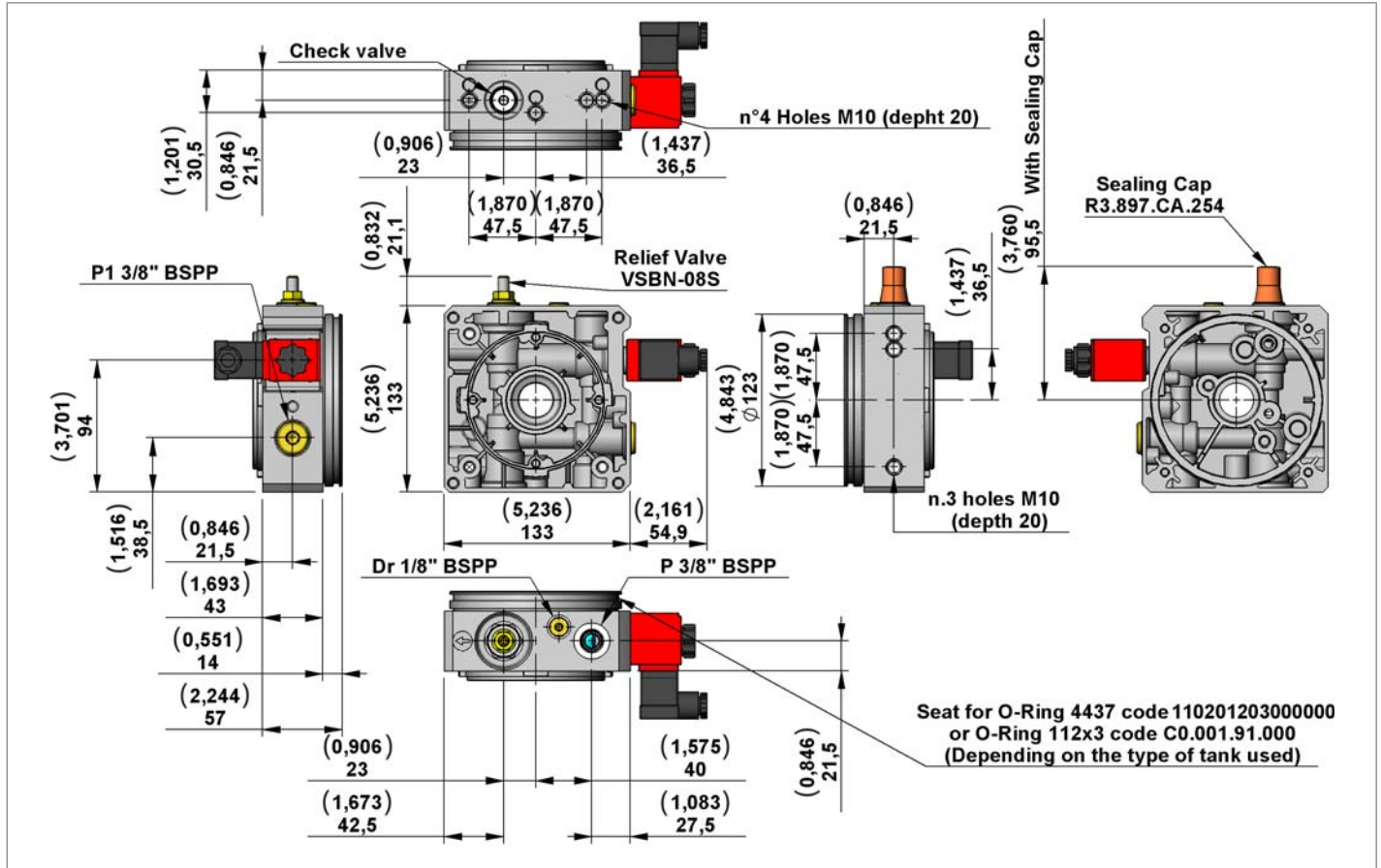

Manifold Code with Relief Valve Pressure Range	Pressure Range bar (psi)	Type	Material Number
KS00/10	35-100 (508-1450)	300B000	R930052312
KS00/20	90-250 (1305-3626)	300C000	R932010081
KS00/35	175-345 (2538-5004)	300D000	R930052302

### View Manifold Tank side

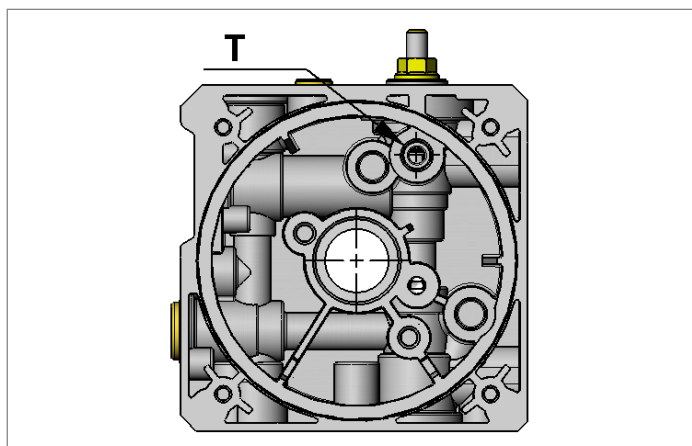

### Manifold Hydraulic Diagram

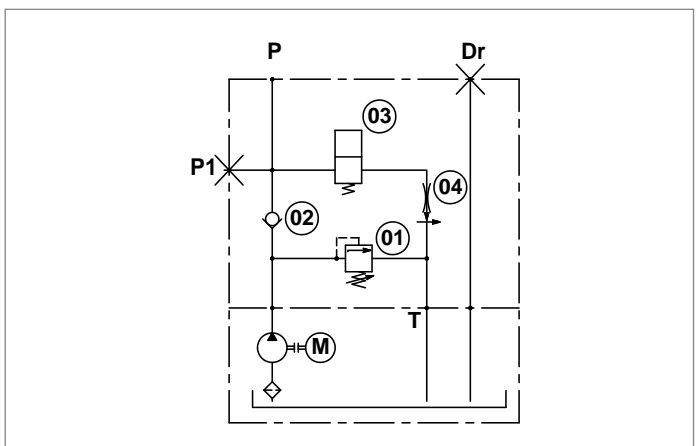

**KS00 with valves**

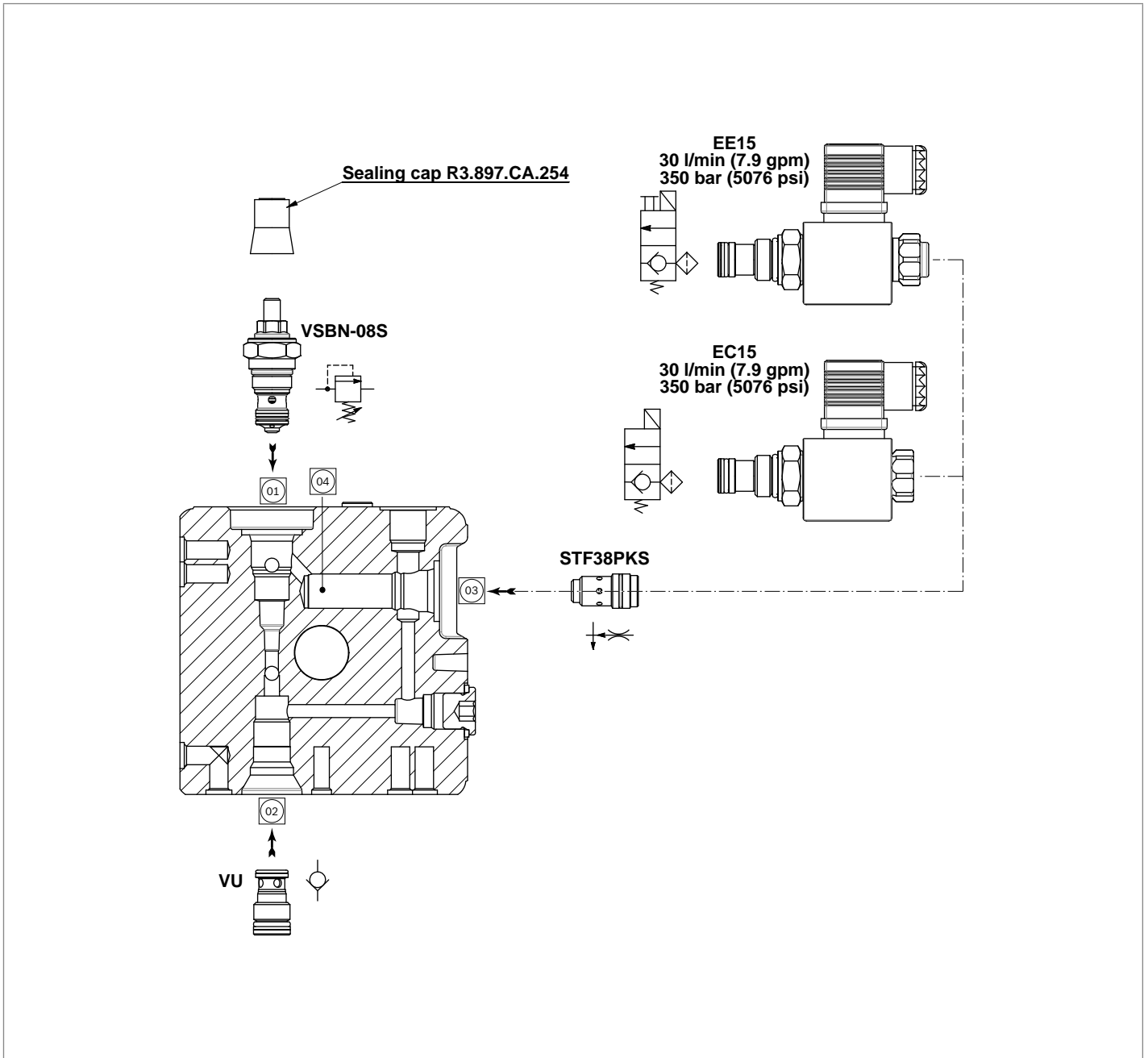

**Note**  
 Steel tank is not available for central manifold KS type.  
 Please contact our sales department for further information.

## Central Manifold KS

### KS02

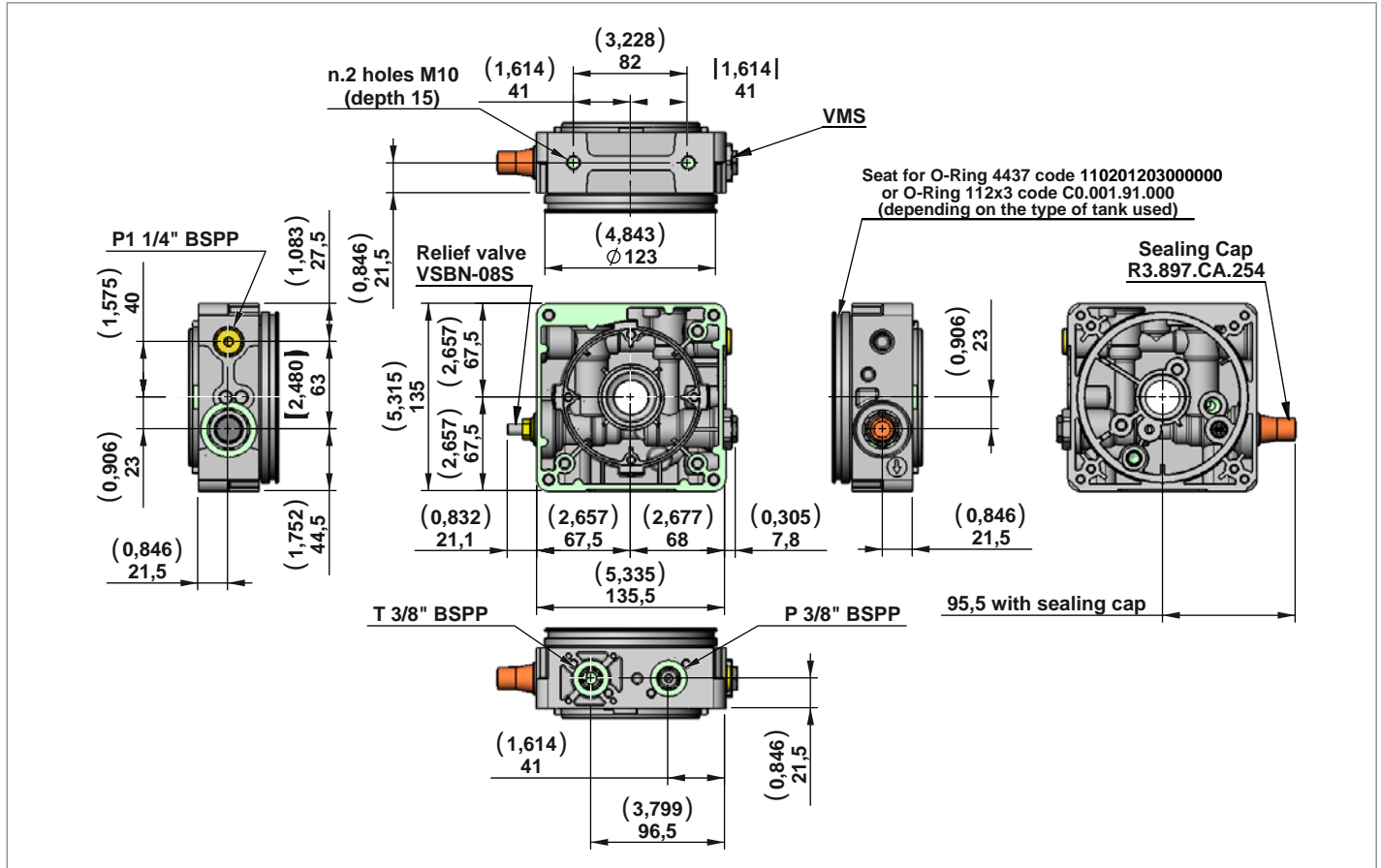

Manifold Code with Relief Valve Pressure Range	Pressure Range bar (psi)	Type	Material Number
KS02/10	35-100 (508-1450)	302B000	R932010304
KS02/20	90-250 (1305-3626)	302C000	R932008762
KS02/35	175-345 (2538-5004)	302D000	R932008763

#### Note

Steel tank is not available for central manifold KS type. Please contact our sales department for further information.

#### View Manifold Tank side

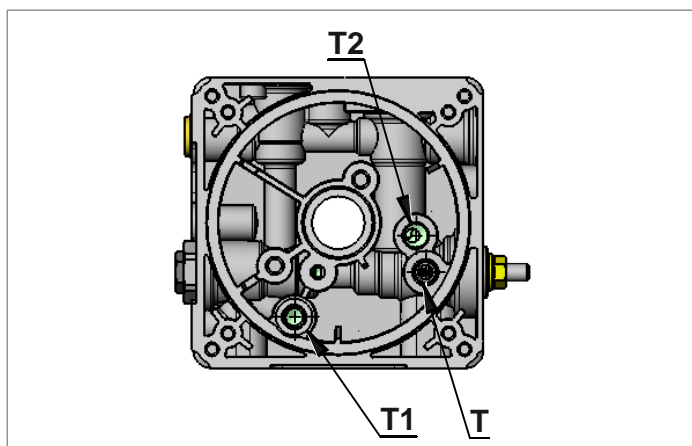

#### Manifold Hydraulic Diagram

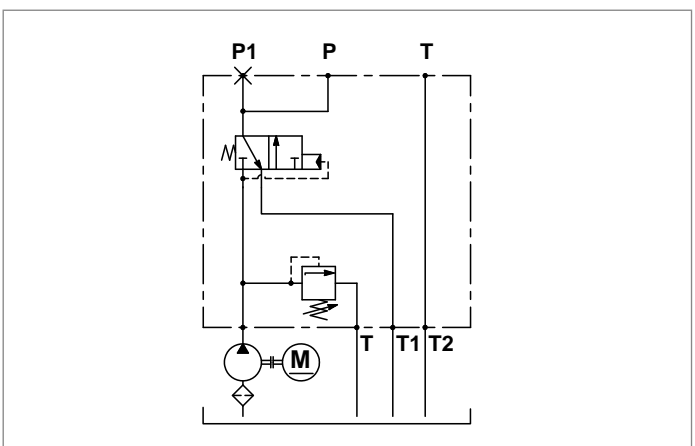

### Built-in Valve

#### VE3-NC Series

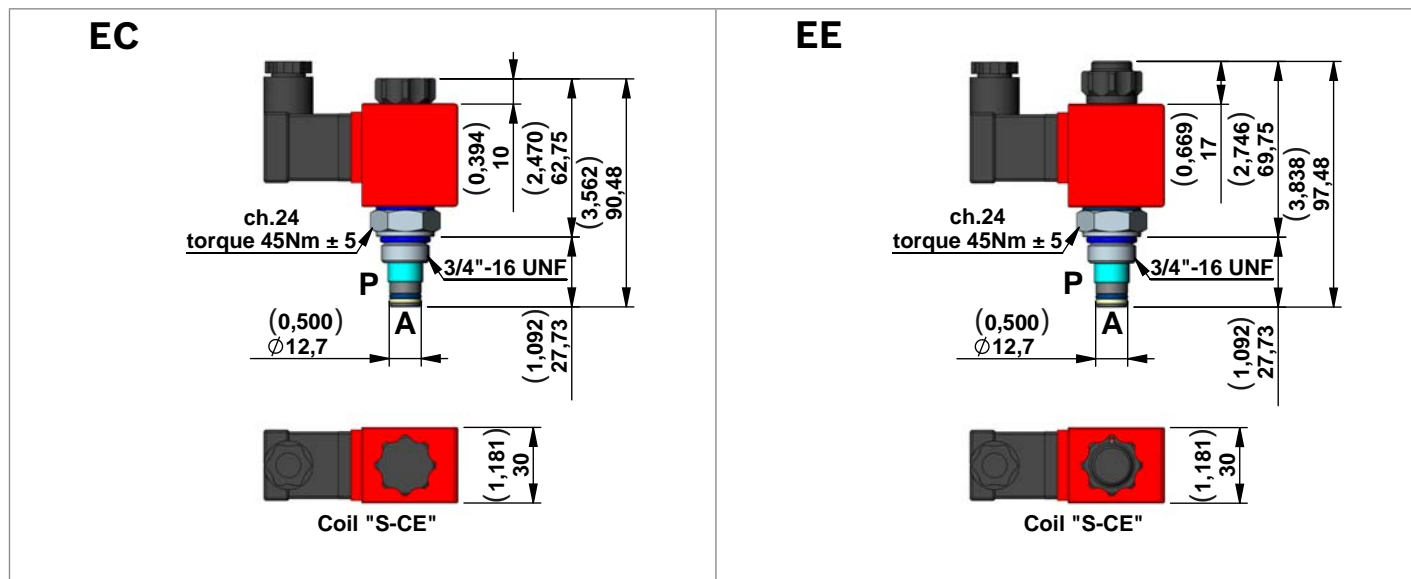

#### 2 Way Pilot Operated Solenoid Valves, Normally Closed for D.C. current

Code	Type	Material Number
EC	K01V389671A20	R932009180
EE	K01V389671E20	R932009181

#### Description

This is a standard 2 way pilot operated valves poppet style.

- **Only for D.C. current.**
- Internal leakage: see technical data.
- Minimum operating voltage: 90% of nominal.
- Screen on P 300 Micron.
- Screw Type Emergency on EE.

#### Valve symbol

Code	Symbol	Operating features with solenoid	
		De-energized	Energized
EC		P ◊ A	P <-> A
EE		P ◊ A	P <-> A

#### Technical Data

General		
Operating time	ms	Opening 30-40 Closing 60-85
Max. working pressure	bar (psi)	350 (5076)
Max. flow	l/min (gpm)	30 (7,92)

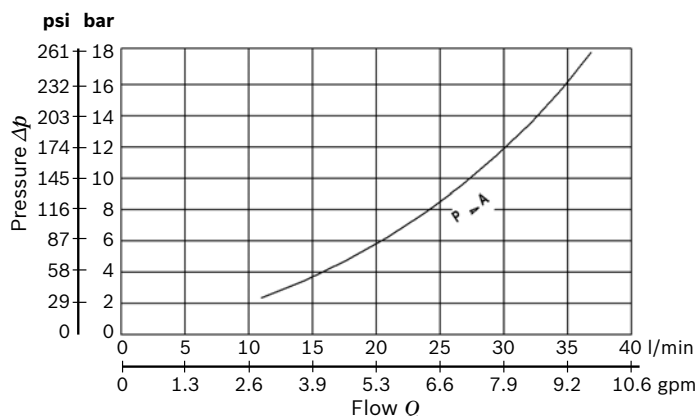

#### S-CE Coil Voltage Available

Voltage
12 Volts D.C.
24 Volts D.C.
48 Volts D.C.
24 Volts RAC
48 Volts RAC
110 Volts RAC
220 Volts RAC

**VE3-NC Series (Special cavity for manifold KS00 and A9)**

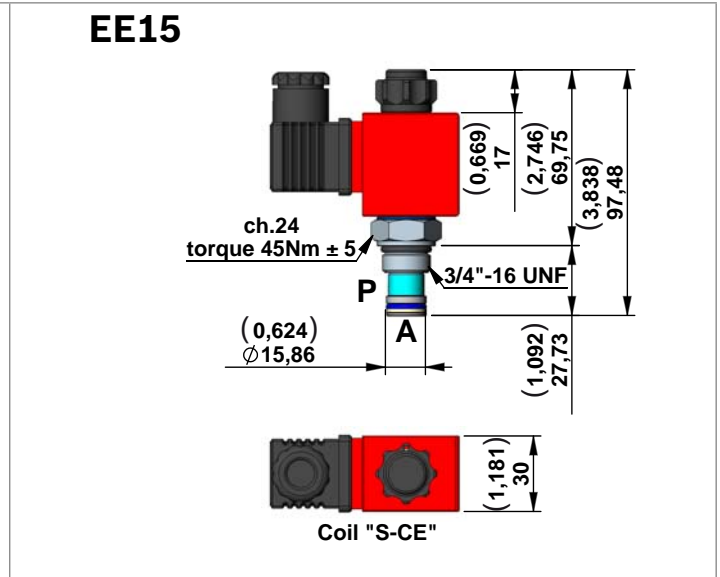
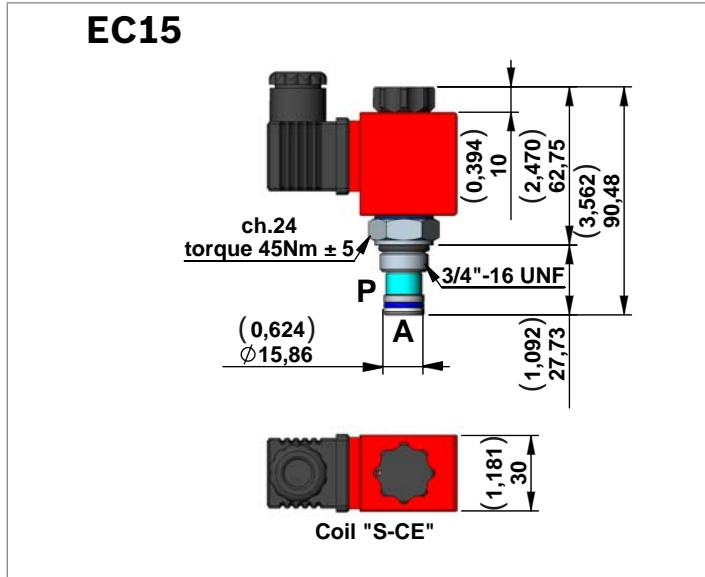

**2 Way Pilot Operated Solenoid Valves,  
Normally Closed for D.C. current**

Code	Type	Material Number
EC15	K01V389671A10	R930052292
EE15	K01V389671E10	R930052293

**Description**

This is a standard 2 way pilot operated valves poppet style.

- **Only for manifolds KS00 and A9 .**
- **Only for D.C. current.**
- Internal leakage: see technical data.
- Minimum operating voltage: 90% of nominal.
- Screen on P 300 Micron.
- Screw Type Emergency on EE.

**Valve symbol**

Code	Symbol	Operating features with solenoid	
		De-energized	Energized
EC15		P ◊ A	P -> A
EE15		P ◊ A	P -> A

**Technical Data**

General		
Operating time	ms	Opening 30-40 Closing 60-85
Max. working pressure	bar (psi)	350 (5076)
Max. flow	l/min (gpm)	30 (7,92)

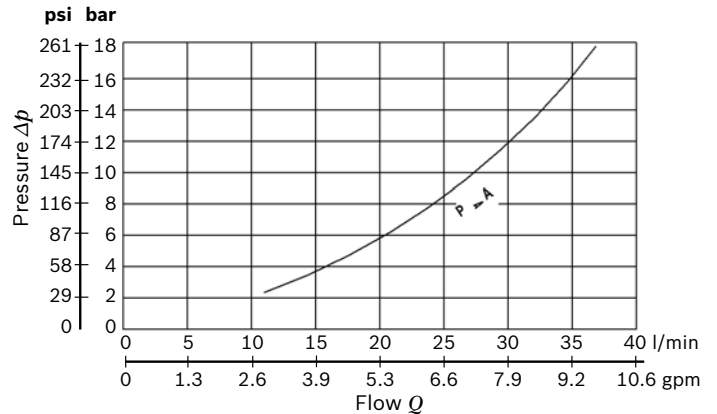

**S-CE Coil Voltage Available**

Voltage
12 Volts D.C.
24 Volts D.C.
48 Volts D.C.
24 Volts RAC
48 Volts RAC
110 Volts RAC
220 Volts RAC

**VE1-NC Series**

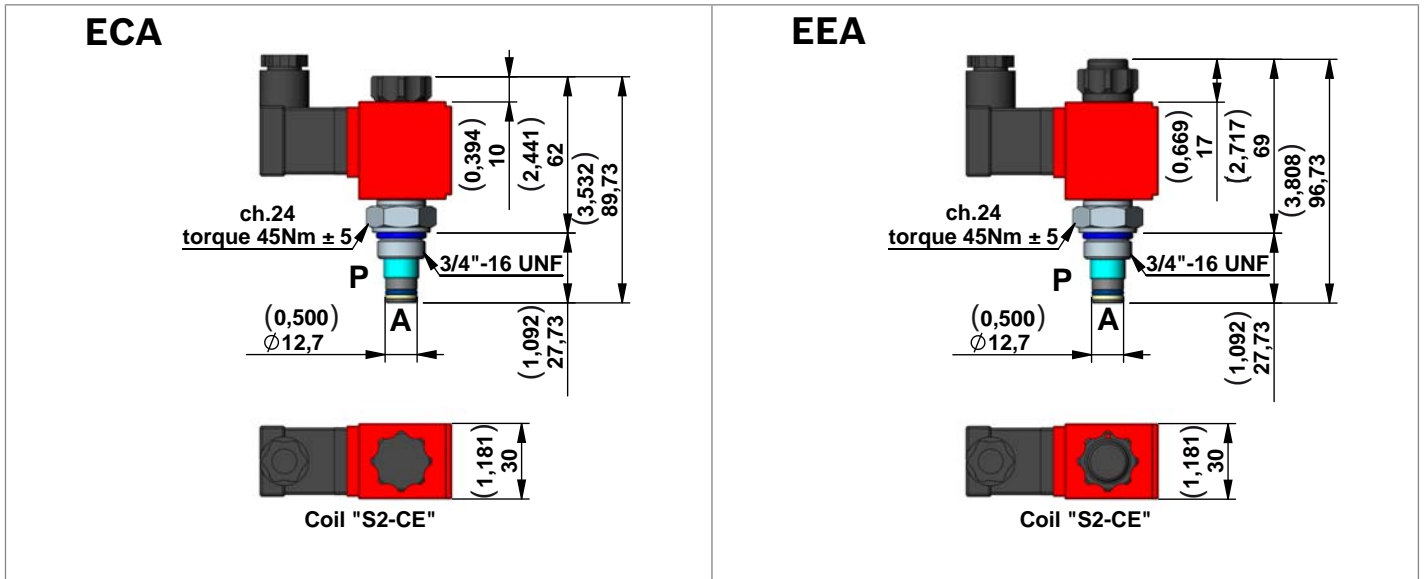

**2 Way Pilot Operated Solenoid Valves,  
Normally Closed for A.C. current**

Code	Type	Material Number
ECA	K01V389669A20	R932009182
EEA	K01V389669E20	R932009183

**Description**

- This is a standard 2 way pilot operated valves poppet style.
- **Only for A.C. current.**
- Internal leakage: see technical data.
- Minimum operating voltage: 90% of nominal.
- Screen on P 300 Micron.
- Screw Type Emergency on EEA.

**Valve symbol**

Code	Symbol	Operating features with solenoid	
		De-energized	Energized
ECA		P ◊ A	P -> A
EEA		P ◊ A	P -> A

**Technical Data**

General		
Operating time	ms	Opening 30-40 Closing 60-85
Max. working pressure	bar (psi)	350 (5076)
Max. flow	l/min (gpm)	30 (7,92)

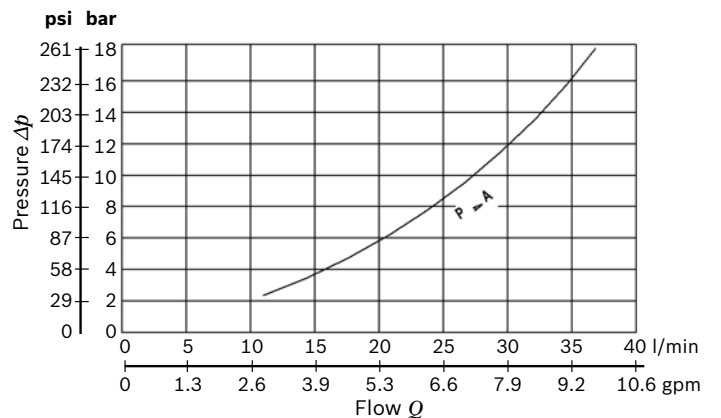

**S2-CE Coil Voltage Available**

Voltage
24 Volts 50 Hz A.C.
220 Volts 50 Hz A.C.
24 Volts 60 Hz A.C.
220 Volts 60 Hz A.C.
24 Volts 50-60 Hz A.C.

**VE3-NA Series**

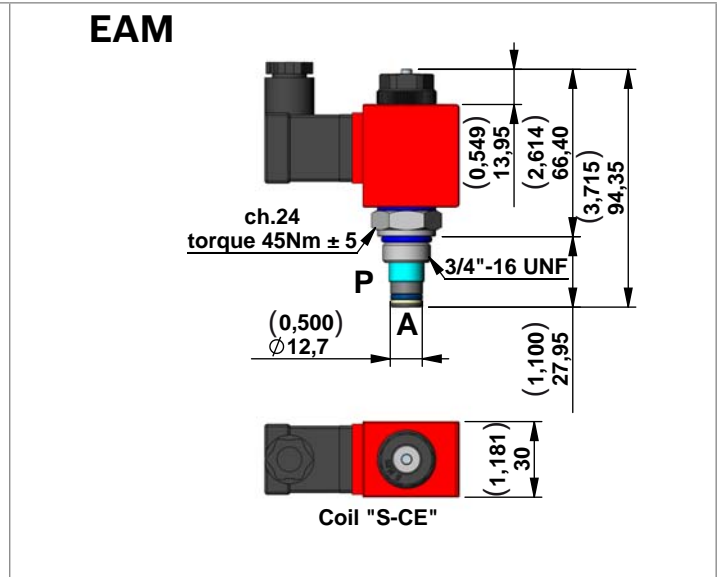
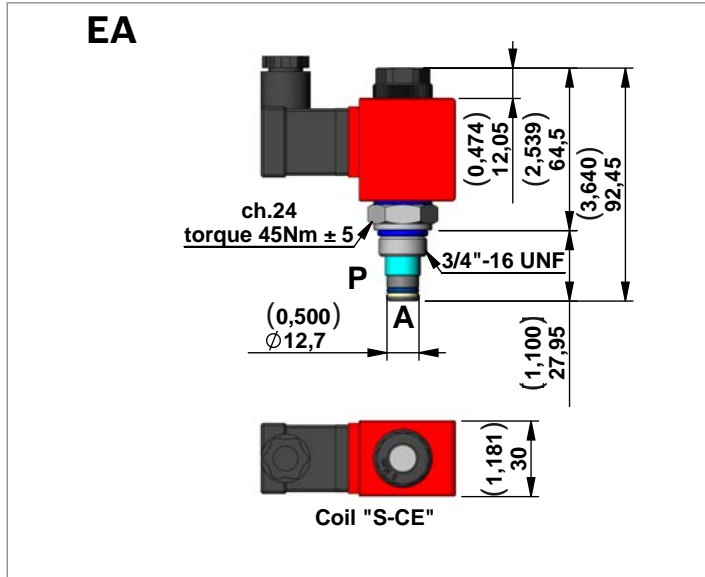

**2 Way Pilot Operated Solenoid Valves, Normally Open**

Code	Type	Material Number
EA	K01V389674A20	R932009184
EAM	K01V389674E20	R932009185

**Technical Data**

General		
Max. working pressure	bar (psi)	230 (3336)
Max. flow	l/min (gpm)	20 (5,28)

**Description**

This is a standard 2 way pilot operated valves poppet style.

- **Only for D.C. current.**
- Internal leakage: see technical data.
- Minimum operating voltage: 90% of nominal.
- Screen on P 300 Micron.
- Push Type Emergency on EAM.

**Valve symbol**

Code	Symbol	Operating features with solenoid	
		De-energized	Energized
EA		P → A	P ◊ A
EAM		P → A	P ◊ A

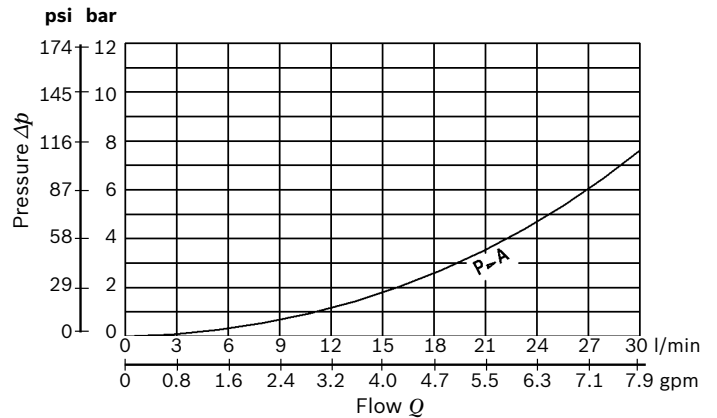

**S-CE Coil Voltage Available**

Voltage
12 Volts D.C.
24 Volts D.C.
48 Volts D.C.
24 Volts RAC
48 Volts RAC
110 Volts RAC
220 Volts RAC



**CEI6-NA Series**

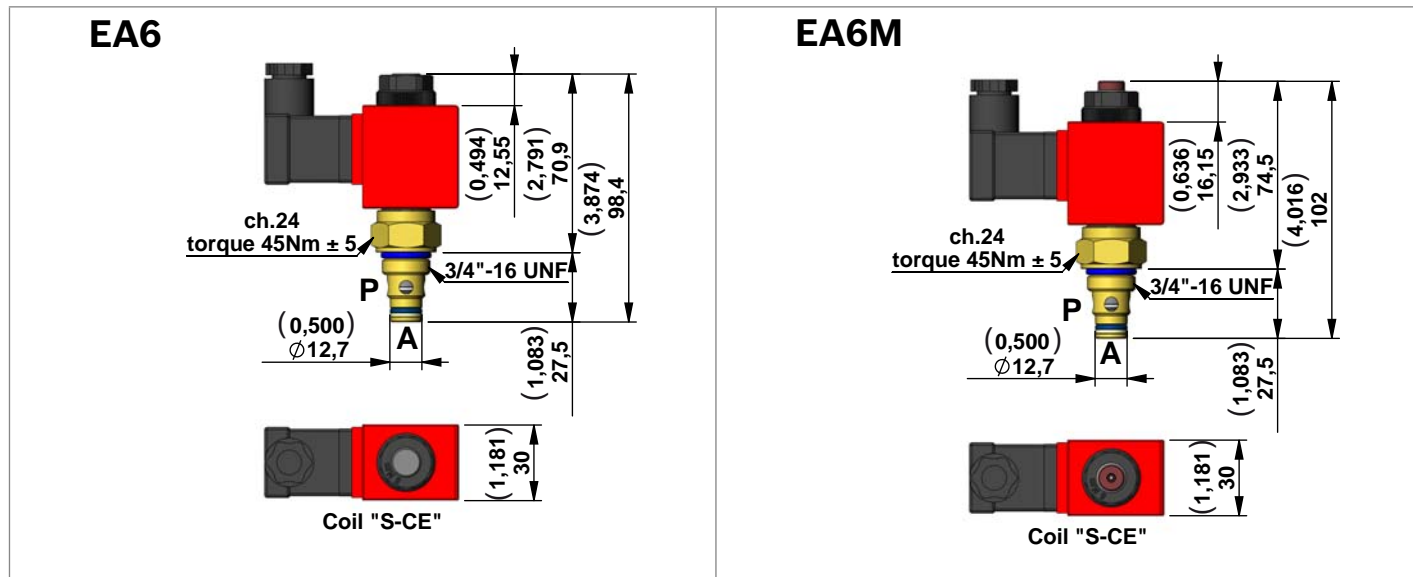

**2 Way Pilot Operated Solenoid Valves, Normally Open**

Code	Type	Material Number
EA6	K01V389664B20	R932009186
EA6M	K01V389664M20	R932009187

**Description**

This is a standard 2 way pilot operated valves poppet style.

- **Only for D.C. current.**
- Internal leakage: see technical data.
- Minimum operating voltage: 90% of nominal.
- Push Type Emergency on EA6M.

**Valve symbol**

Code	Symbol	Operating features with solenoid	
		De-energized	Energized
EA6		P → A	P ◊ A
EA6M		P → A	P ◊ A

**Technical Data**

General		
Max. working pressure	bar (psi)	350 (5076)
Max. flow	l/min (gpm)	40 (10,57)

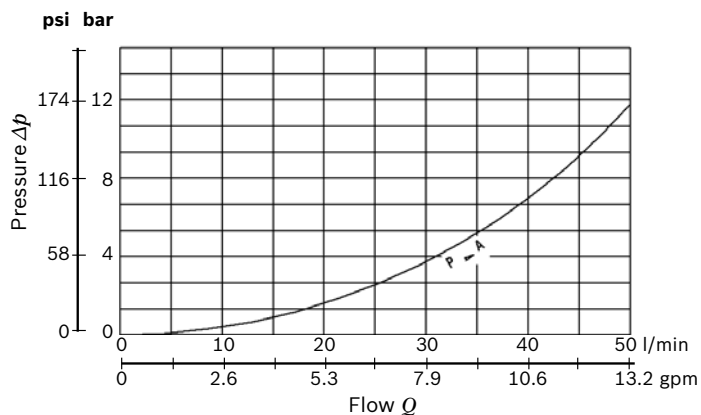

**S-CE Coil Voltage Available**

Voltage
12 Volts D.C.
24 Volts D.C.
48 Volts D.C.
24 Volts RAC
48 Volts RAC
110 Volts RAC
220 Volts RAC

**CE3-DT Series (for manifold M32)**

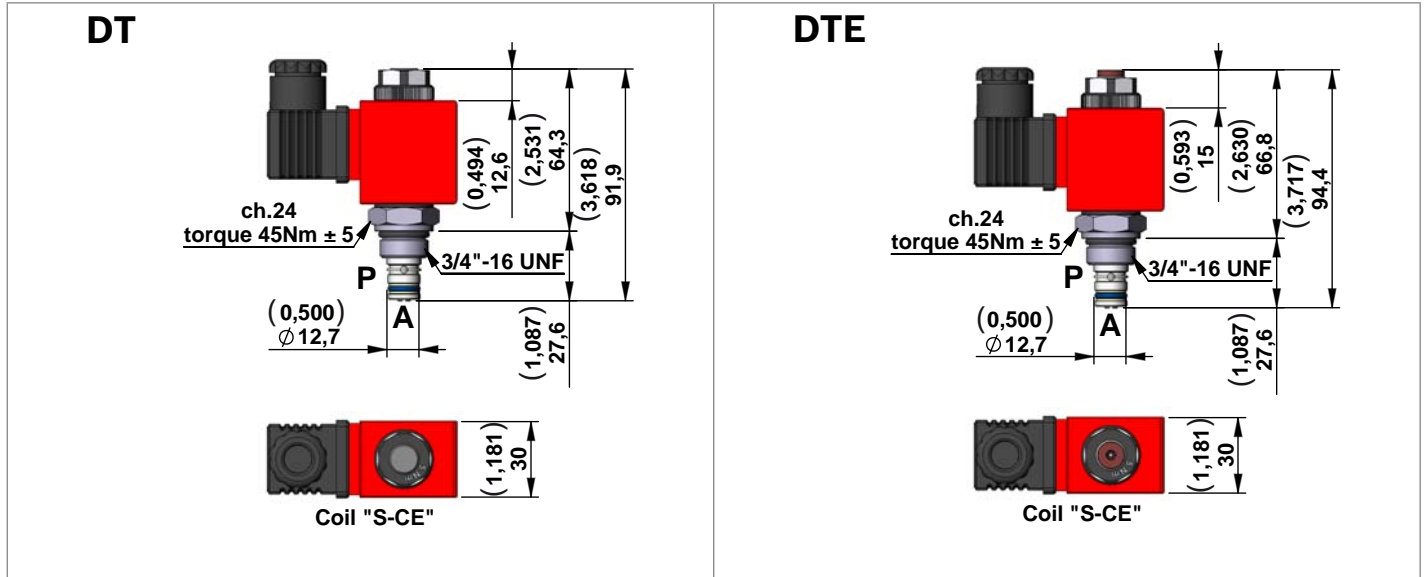

**2 Way direct acting double lock Solenoid Valves,  
Normally Closed for D.C. current**

Code	Type	Material Number
DT	K01V389622A20	R930053009
DTE	K01V389622E20	R930053010

**Description**

On this valve the oil can pass free or can be perfectly locked on each ports "P" and "A".

- **Only for D.C. current.**
- Internal leakage: see technical data.
- Minimum operating voltage: 90% of nominal.
- Push Type Emergency on DTE push..

**Valve symbol**

Code	Symbol	Operating features with solenoid	
		De-energized	Energized
DT		P → A A → P	P → A A → P
DTE		P → A A → P	P → A A → P

**Technical Data**

General		
Operating time	ms	Opening 15-20 Closing 20-45
Max. working pressure	bar (psi)	210 (3046)
Max. flow	l/min (gpm)	15 (3,96)

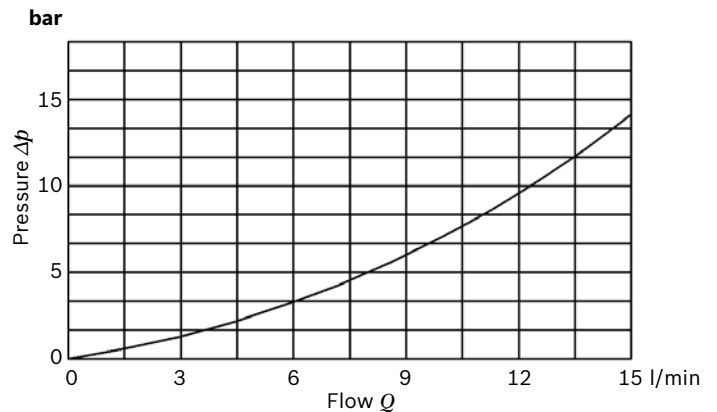

**S-CE Coil Voltage Available**

Voltage
12 Volts D.C.
24 Volts D.C.
48 Volts D.C.
24 Volts RAC
48 Volts RAC
110 Volts RAC
220 Volts RAC

**V3D-DT Series**

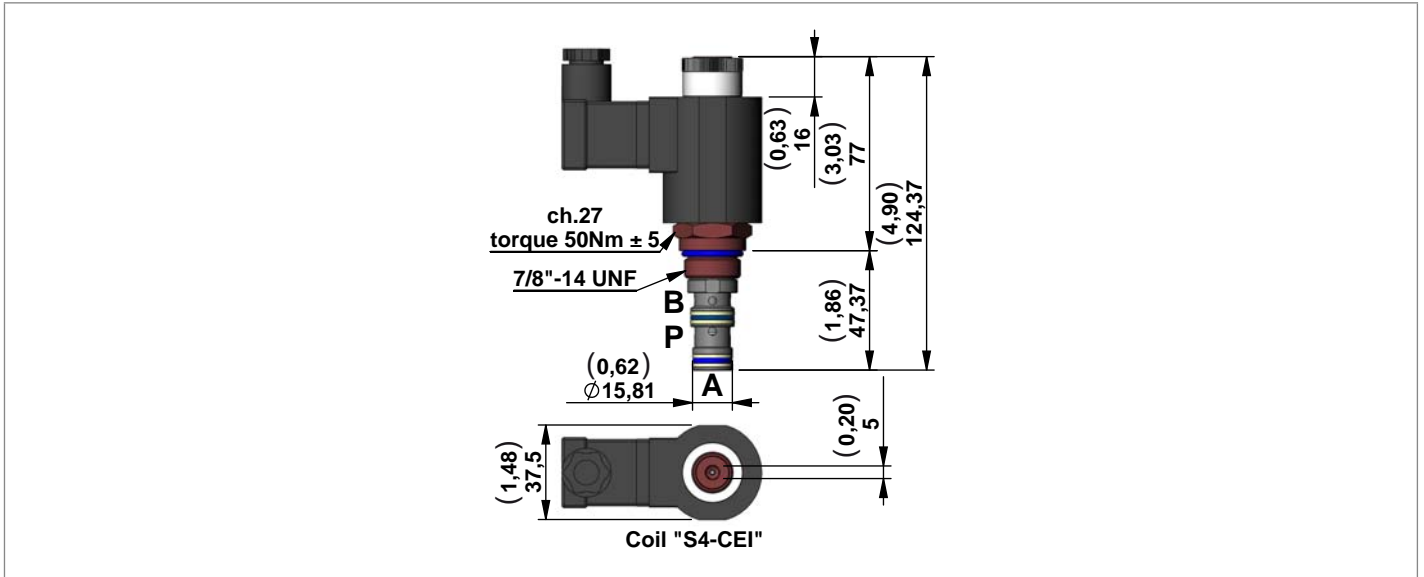

**3 Way Direct Acting Poppet Style Solenoid Valves**

Code	Type	Material Number
V3DT	K01V389643A00	R932009299

**Description**

3 Way Direct Acting Poppet Style Solenoid Valves

- **Only for D.C. current.**
- Internal leakage: see technical data.
- Minimum operating voltage: 90% of nominal.
- Push Type Emergency.

**Valve symbol**

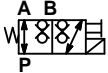
Code	Symbol	Operating features with solenoid	
		De-energized	Energized
V3DT		P ↔ A B ○ ○	P ↔ B A ○ ○

**Technical Data**

General		
Max. working pressure	bar (psi)	250 (3626)
Max. flow	l/min (gpm)	20 (5,28)

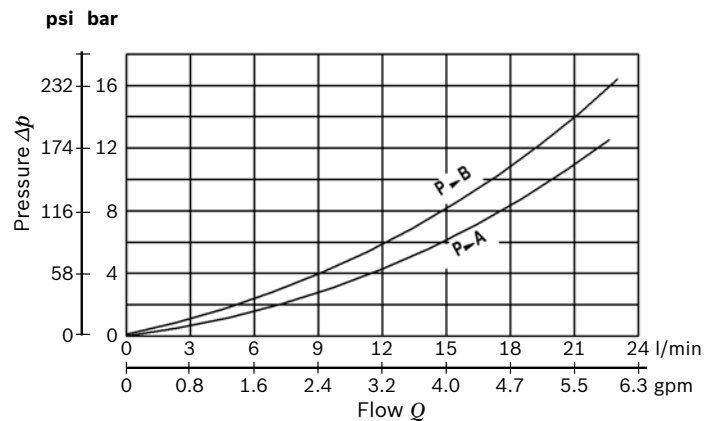

**S4-CEI Coil Voltage Available**

Voltage
12 Volts D.C.
24 Volts D.C.
24 Volts RAC
110 Volts RAC
220 Volts RAC

**V4DS-2P Series**

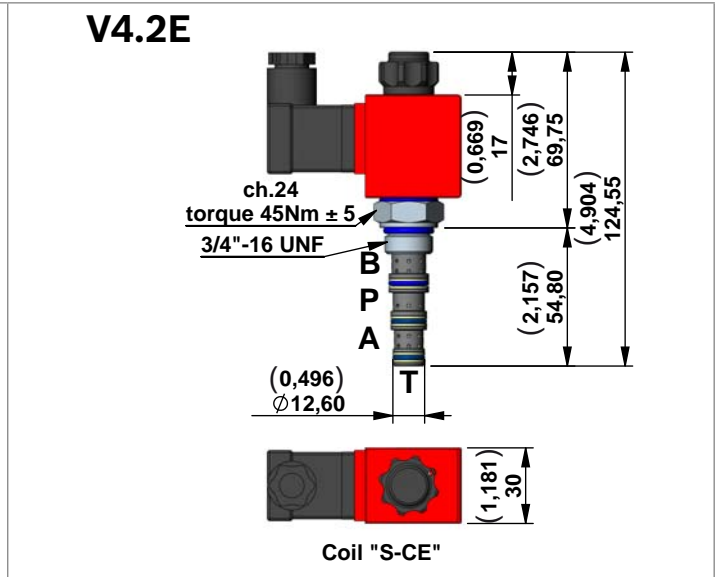
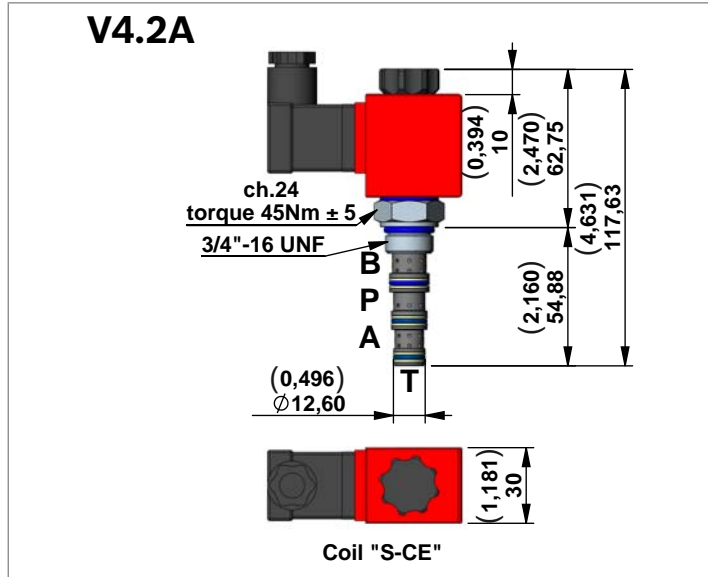

**4 Way 2 Position Solenoid Valves Spool Type**

Code	Type	Material Number
V4.2A	K01V389656A00	R932009300
V4.2E	K01V389656E00	R932009301

**Description**

4 Way 2 Position Solenoid Valves Spool Type

- **Only for D.C. current.**
- Minimum operating voltage: 90% of nominal.
- Screw Type Emergency on V4.2E.

**Valve symbol**

Code	Symbol	Operating features with solenoid	
		De-energized	Energized
V4.2A		P ↔ A B ↔ T	P ↔ B A ↔ T
V4.2E		P ↔ A B ↔ T	P ↔ B A ↔ T

**Technical Data**

General		
Max. working pressure	bar (psi)	210 (3046)
Max. flow	l/min (gpm)	8 (2,11)

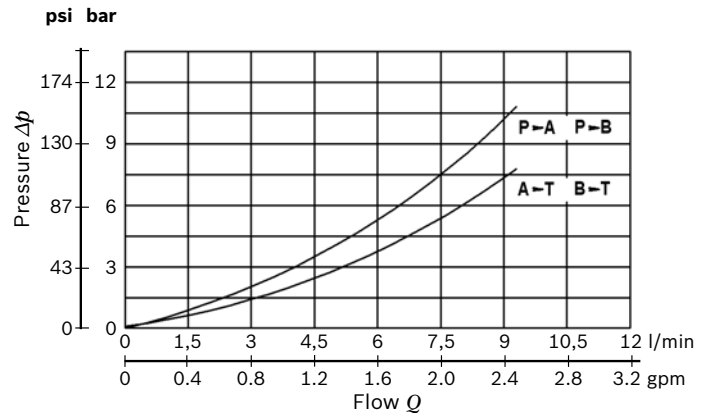

**S-CE Coil Voltage Available**

Voltage
12 Volts D.C.
24 Volts D.C.
48 Volts D.C.
24 Volts RAC
48 Volts RAC
110 Volts RAC
220 Volts RAC

**V4D-CEI-2P Series**

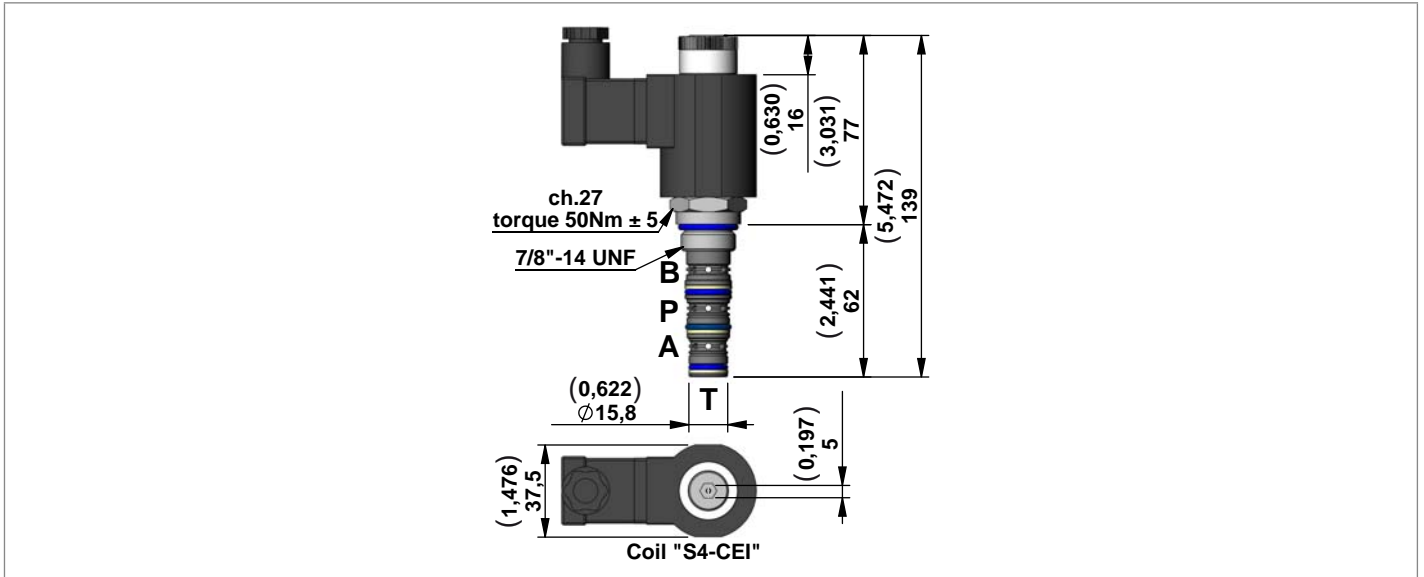

**4 Way 2 Position Solenoid Valves Spool Type**

Code	Type	Material Number
V4I.2E	K01V389631A10	R932009302

**Description**

4 Way 2 Position Solenoid Valves, Spool Type

- **Only for D.C. current.**
- Minimum operating voltage: 90% of nominal.
- Push Type Emergency.

**Valve symbol**

Code	Symbol	Operating features with solenoid	
		De-energized	Energized
V4I.2E		P ↔ B A ↔ T	P ↔ A B ↔ T

**Technical Data**

General		
Max. working pressure	bar (psi)	see diagram
Max. flow	l/min (gpm)	25 (6,60)

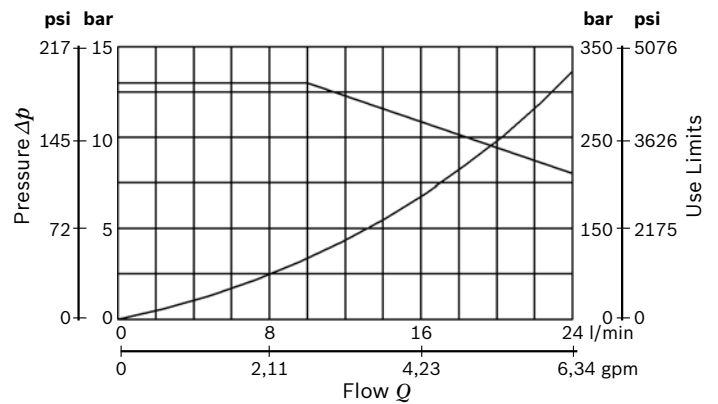

**S4-CEI Coil Voltage Available**

Voltage
12 Volts D.C.
24 Volts D.C.
24 Volts RAC
110 Volts RAC
220 Volts RAC

**V4DS-3P Series**

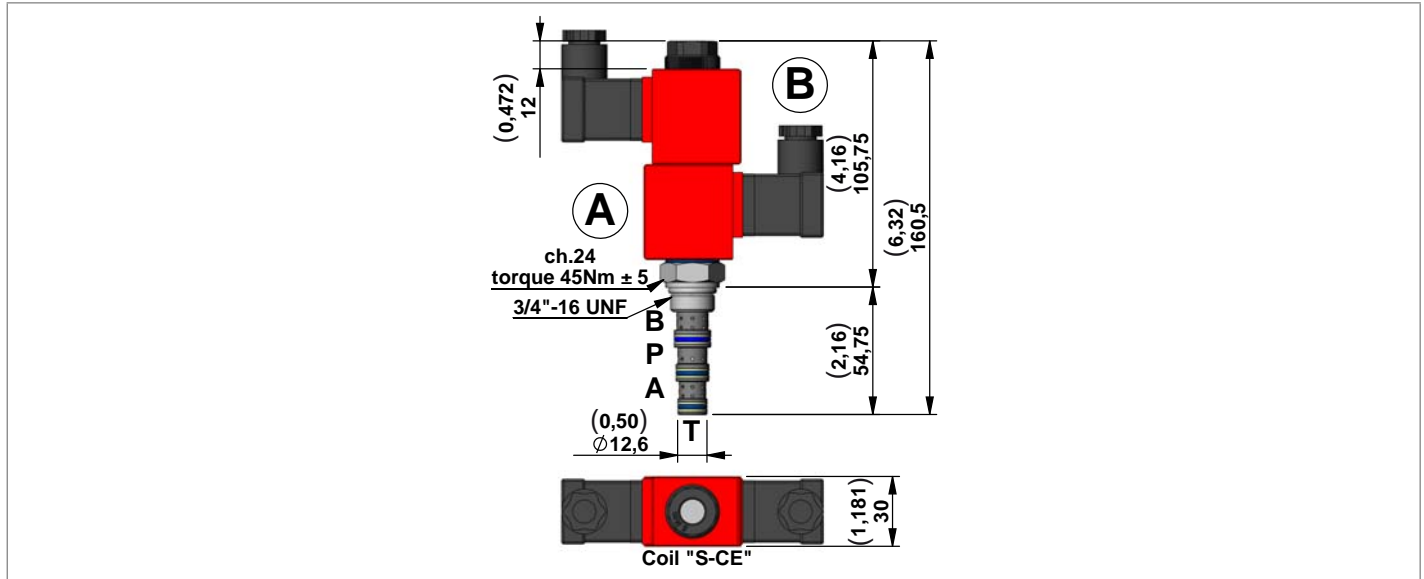

**4 Way 3 Position Solenoid Valves Spool Type**

Code	Type	Material Number
V4.3A	K01V389657A00	R932009303
V4.3B	K01V389657B00	R932009304
V4.3C	K01V389657C00	R932009305

**Description**

4 Way 3 Position Solenoid Valves Spool Type  
 - **Only for D.C. current.**  
 - Minimum operating voltage: 90% of nominal.

**Valve symbol**

Code	Symbol	Operating features with solenoid		
		Energized A	De-energized	Energized B
V4.3A		P → B A → T	P P A ∅ ∅ A B B T T	P → A B → T
V4.3B		P → B A → T	A → T B → T P ∅	P → A B → T
V4.3C		P → B A → T	P P A ↔ A B B T T	P → A B → T

**Technical Data**

General		
Max. working pressure	bar (psi)	210 (3046)
Max. flow	l/min (gpm)	8 (2,11)

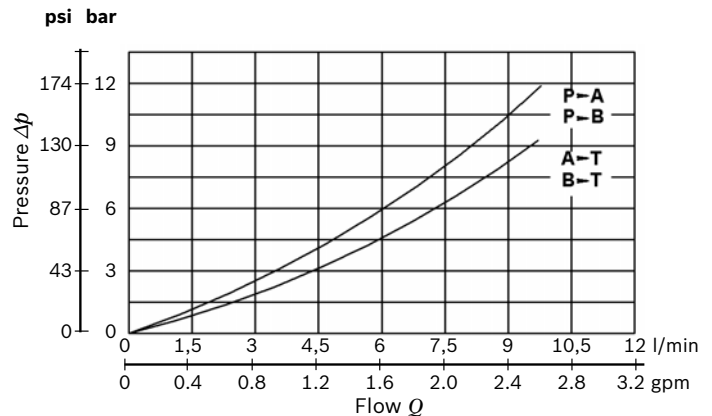

**S-CE Coil Voltage Available**

Voltage
12 Volts D.C.
24 Volts D.C.
48 Volts D.C.
24 Volts RAC
48 Volts RAC
110 Volts RAC
220 Volts RAC

**V4D-CEI-3P Series**

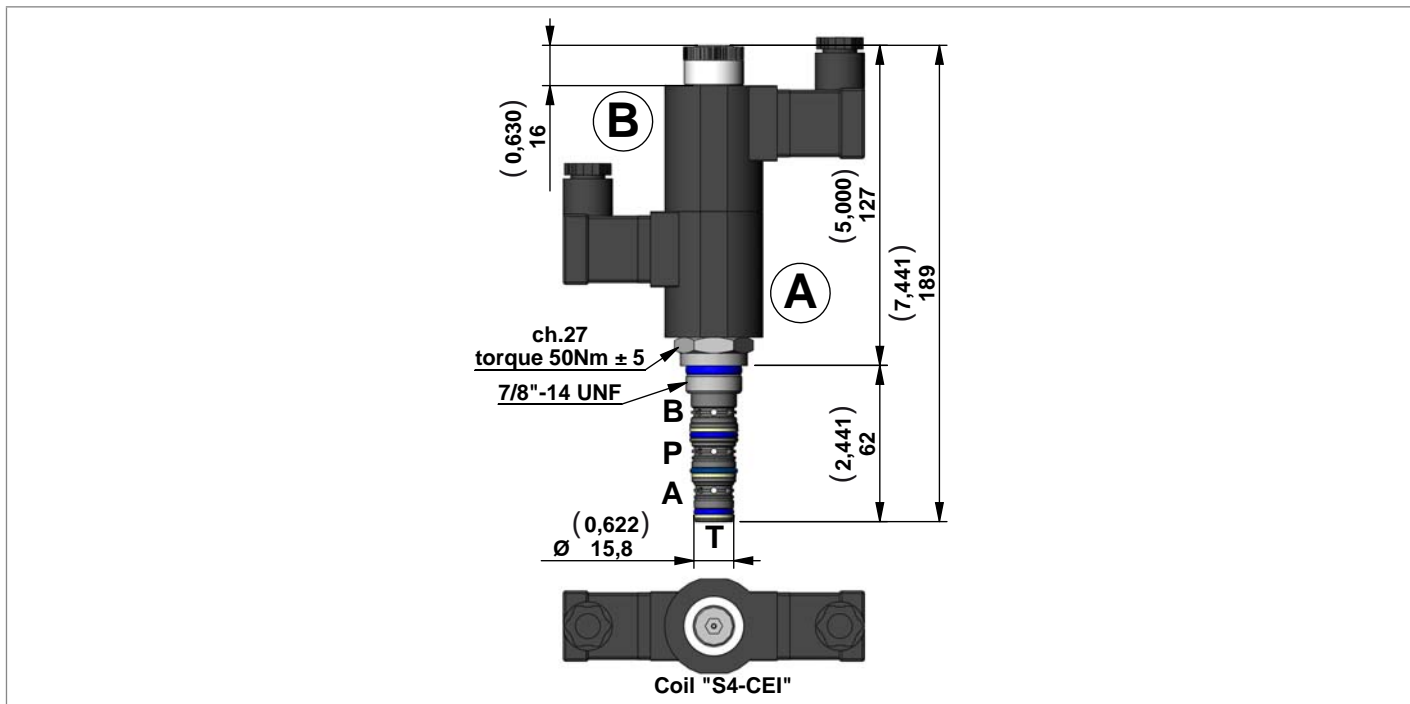

**4 Way 3 Position Solenoid Valves Spool Type**

Code	Type	Material Number
V4I.3C	K01V389633C10	R932009308

**Description**

- 4 Way 3 Position Solenoid Valves, Spool Type
- Only for D.C. current.
  - Minimum operating voltage: 90% of nominal.
  - Push Type Emergency (only function coil B).

**Valve symbol**

Code	Symbol	Operating features with solenoid		
		Energized A	De-energized	Energized B
V4I.3C		P → B A → T	A ∅ B ∅ P → T	P → A B → T

**Technical Data**

General		
Max. working pressure	bar (psi)	see diagram
Max. flow	l/min (gpm)	25 (6,60)

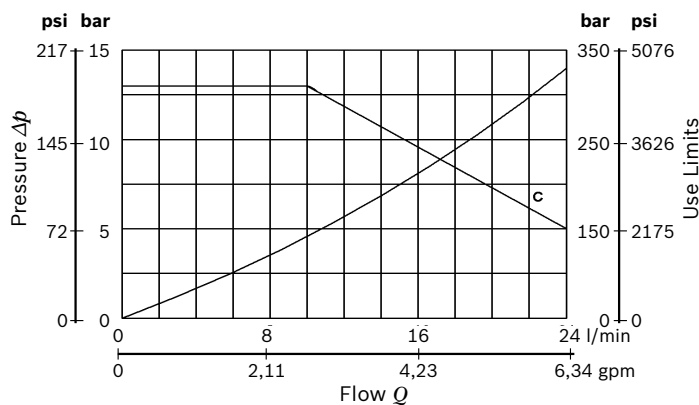

**S4-CEI Coil Voltage Available**

Voltage
12 Volts D.C.
24 Volts D.C.
24 Volts RAC
110 Volts RAC
220 Volts RAC

**COIL Model S-CE – 18W – ED 100%**

**for valves VE3-NC, VE3-NA, V4DS-2P, V4DS-3P Series**

Coil protection: Polyamide resin with fiber glass for Heat insulation class F (155°C (311°F)) IXEF for Heat insulation class H (180°C (356°F)).

Solenoids “S-CE” (18 W) are designed for continuous duty ED100%.

Ambient temperature range: -15°/+40°

Inlet voltage fluctuations must not exceed +/- 10% of nominal voltage to obtain correct operations and long life coils

Protection degree: see tables below

**DIN 43650 - ISO 4400 IP65 with connector assembled**

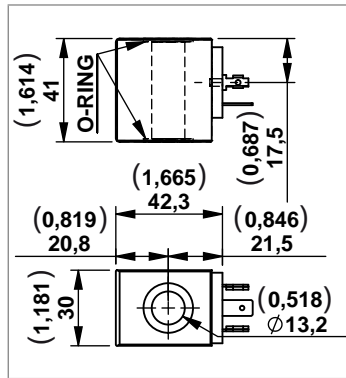

Code	Voltage	Heat Insulation class	Type	Material Number
<b>OB</b>	12 Volts D.C.	F (155°C) (311°F)	C166455OB1	R932000804
<b>OC</b>	24 Volts D.C.	F (155°C) (311°F)	C166455OC1	R932000805
<b>OD</b>	48 Volts D.C.	F (155°C) (311°F)	C166455OD1	R932000806
<b>OBH</b>	12 Volts D.C.	H (180°C) (356°F)	C166462OB1	R932000819
<b>OCH</b>	24 Volts D.C.	H (180°C) (356°F)	C166462OC1	R932000820
<b>OV</b>	24 Volts RAC	H (180°C) (356°F)	C166462OV1	R932000821
<b>OK</b>	48 Volts RAC	H (180°C) (356°F)	C166462OK1	R932008238
<b>OW</b>	110 Volts RAC	H (180°C) (356°F)	C166462OW1	R932008239
<b>OZ</b>	220 Volts RAC	H (180°C) (356°F)	C166462OZ1	R932000822

**AMP JUNIOR IP67**

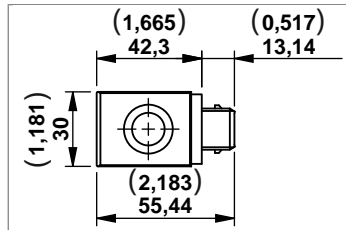

Code	Voltage	Heat Insulation class	Type	Material Number
<b>OBA</b>	12 Volts D.C.	F (155°C) (311°F)	C166458OB1	R932000815
<b>OCA</b>	24 Volts D.C.	F (155°C) (311°F)	C166458OC1	R932000816

**SINGLE LEAD IP54**

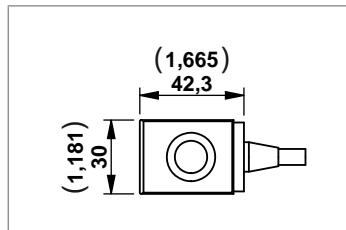

Code	Voltage	Heat Insulation class	Type	Material Number
<b>OBL</b>	12 Volts D.C.	F (155°C) (311°F)	C166467OB00600F	R932009109
<b>OCL</b>	24 Volts D.C.	F (155°C) (311°F)	C166467OC00600F	R932007010

Cable Length 600mm

**DEUTSCH DT04-2P-V IP67**

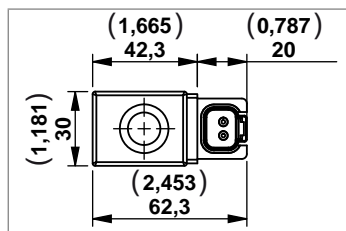

Code	Voltage	Heat Insulation class	Type	Material Number
<b>OBD</b>	12 Volts D.C.	F (155°C) (311°F)	C166463OB1	R932000823
<b>OCD</b>	24 Volts D.C.	F (155°C) (311°F)	C166463OC1	R932009110



**COIL Model S2-CE – 18W – ED 100%**  
**for valves VE1-NC Series**

Coil protection: Polyamide resin with fiber glass for Heat insulation class F (155°C) (311°F).

Solenoids “S2-CE” (18 W) are designed for continuous duty ED100%.

Ambient temperature range : -15°/+40°

Inlet voltage fluctuations must not exceed +/- 10% of nominal voltage to obtain correct operations and long life coils

Protection degree: IP65 IEC 144 – DIN 40050 (total protection against dust and low pressure jets) with connector

**DIN 43650 - ISO 4400 IP65 (with connector assembled)**

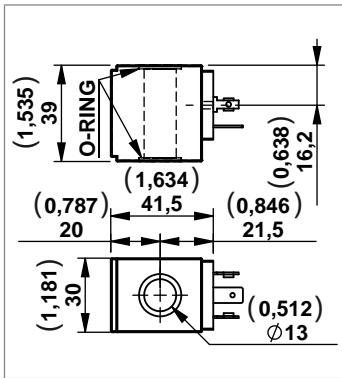

Code	Voltage	Heat Insulation class	Type	Material Number
OH	24 Volts 50 Hz A.C.	F (155°C) (311°F)	C166401OH1	R932000762
ON	220 Volts 50 Hz A.C.	F (155°C) (311°F)	C166401ON1	R932000766
OP	24 Volts 60 Hz A.C.	F (155°C) (311°F)	C166401OP1	R932000767
OS	220 Volts 60 Hz A.C.	F (155°C) (311°F)	C166401OS1	R932000769
OU	24 Volts 50-60 Hz A.C.	F (155°C) (311°F)	C166401OU1	R932000771

**COIL Model S4-CEI – 26W – ED 100%**

**for valves V3D-DT , V4D-CEI-2P , V4D-CEI-3P Series**

Coil protection: Polyamide resin with fiber glass for Heat insulation class F (155°C) (311°F).

Solenoids “S4-CEI” (18 W) are designed for continuous duty ED100%.

Ambient temperature range: -15°/+40°

Inlet voltage fluctuations must not exceed +/- 10% of nominal voltage to obtain correct operations and long life coils

Protection degree: see tables below

**DIN 43650 - ISO 4400 IP65 with connector assembled**

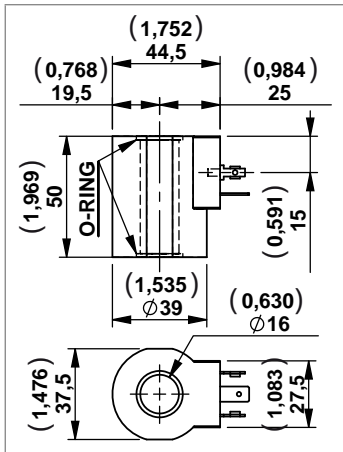

Code	Voltage	Heat Insulation class	Type	Material Number
<b>OB</b>	12 Volts D.C.	F (155°C) (311°F)	C166437OB1	R932000789
<b>OC</b>	24 Volts D.C.	F (155°C) (311°F)	C166437OC1	R932000790
<b>OV</b>	24 Volts RAC	F (155°C) (311°F)	C166437OV1	R932000791
<b>OW</b>	110 Volts RAC	F (155°C) (311°F)	C166437OW1	R932000792
<b>OZ</b>	220 Volts RAC	F (155°C) (311°F)	C166437OZ1	R932000793

**AMP JUNIOR IP67**

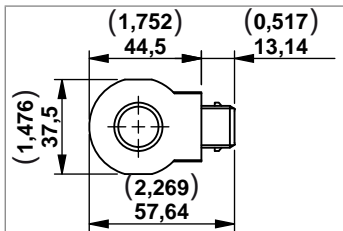

Code	Voltage	Heat Insulation class	Type	Material Number
<b>OBA</b>	12 Volts D.C.	F (155°C) (311°F)	C166471OB1	R932000835
<b>OCA</b>	24 Volts D.C.	F (155°C) (311°F)	C166471OC1	R932000836

**SINGLE LEAD IP54**

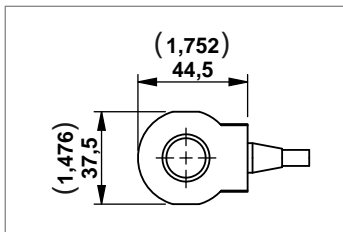

Code	Voltage	Heat Insulation class	Type	Material Number
<b>OBL</b>	12 Volts D.C.	F (155°C) (311°F)	C166453OB00600F	R932009107
<b>OCL</b>	24 Volts D.C.	F (155°C) (311°F)	C166453OC00600F	R932007009

Cable Length 600mm

**DEUTSCH DT04-2P-V IP67**

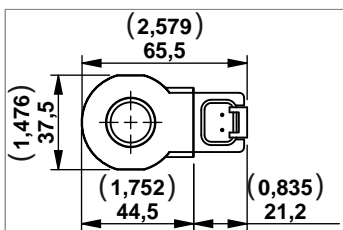

Code	Voltage	Heat Insulation class	Type	Material Number
<b>OBD</b>	12 Volts D.C.	F (155°C) (311°F)	C166461OB1	R932000818
<b>OCD</b>	24 Volts D.C.	F (155°C) (311°F)	C166461OC1	R932009108

**CONNECTOR IP67 - EN175000 (DIN 4350-A) / ISO 4400**

Ambient temperature - Standard	°C (°F)	- 20 to + 60 (-4 to +140°F)
Type of protection according to DIN 40050		IP67 with cable socket mounted and locked
Operating voltage	V	Choose the proper ordering code according to the circuit
Maximum operating current	Standard	A 16
	With rectifier	A 1
Number of pins		2 + PE
Clamping range for cables having an outer diameter of	mm (inch)	5, up to 10 (0,2 up to 0,4)
Cable entry		Pg9 / Pg11 (unified)
Maximum cable cross-section	mm <sup>2</sup> (inch <sup>2</sup> )	1.5 (0,002)

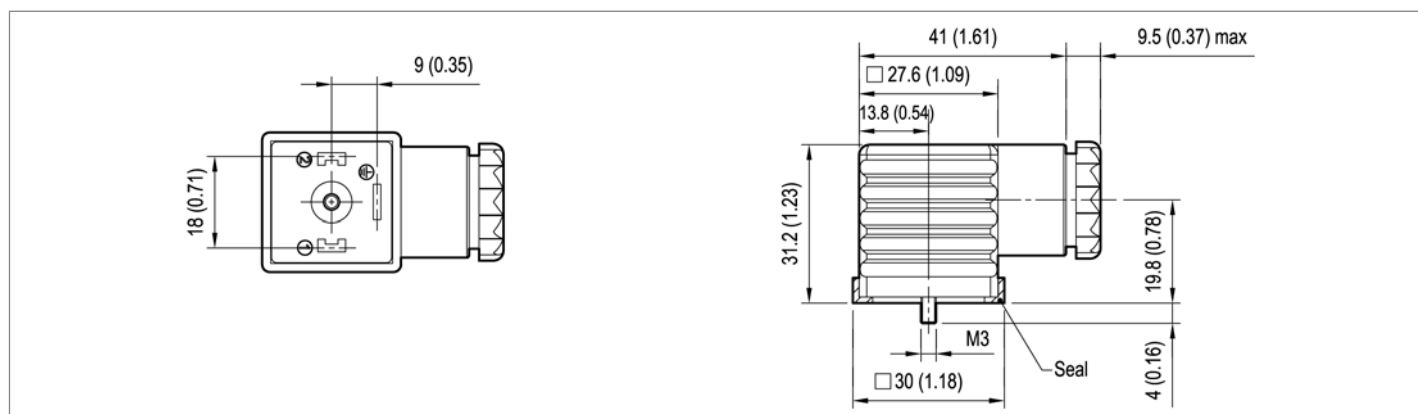

**Standard Circuit**

Code	Colour	Cable entry	Type	Material Number
<b>WC</b>	Without Connector			
<b>CS</b>	black	Pg9 / Pg11	OD01690100000	R934004344
	grey	Pg9 / Pg11	OD01690100003	R934004346

**Circuit with VDR + Wave Rectifier**

Code	Voltage V		Diode Capacity I max	Colour	Cable entry	Type	Material Number
	AC	DC					
<b>CR</b>	230	/	1A	black	Pg9 / Pg11	OD01690201OZ00	R934004353

**Note**

Diode with capacity max 1 Amp.

**Note**

Black is the standard colour. Grey is used in case of valves with 2 coils (V4DS-3P and V4D-CEI-3P Series).

**MC**

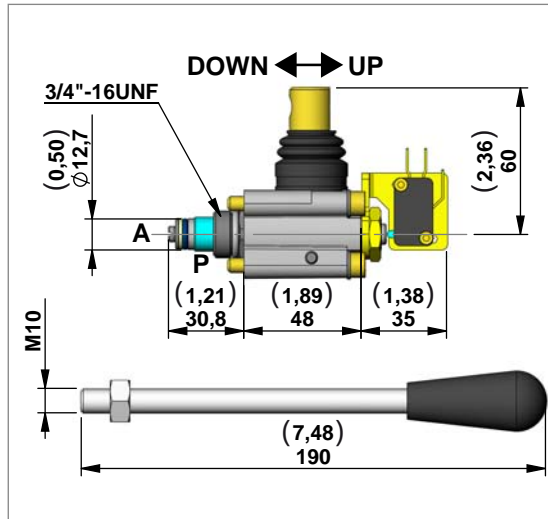

Type	Material Number				
K250113000	R932002448				
Technical Data					
General					
Max. working pressure	bar (psi) 300 (4500)				
2 Way Manual Operated Cartridge Valve					
Code	Microswitch Diagram	Compatibility	Type with lever	Material Number with lever	
MC	without		K - KE	V389280B20LV190	R932003809
MC17	with			V389280C20LV190	R932003811

**MCR**

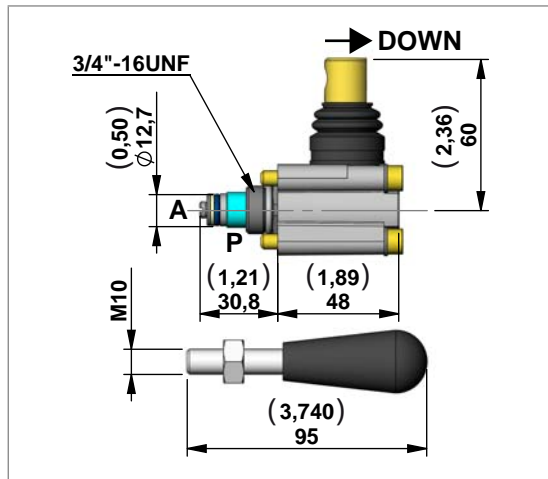

Type	Material Number			
K250121000	R932002451			
Technical Data				
General				
Max. working pressure	bar (psi) 300 (4500)			
2 Way Manual Operated Cartridge Valve				
Code	Diagram	Compatibility	Type with lever	Material Number with lever
MCR		K - KE	V389281020LV095	R932003816

**PMC12**

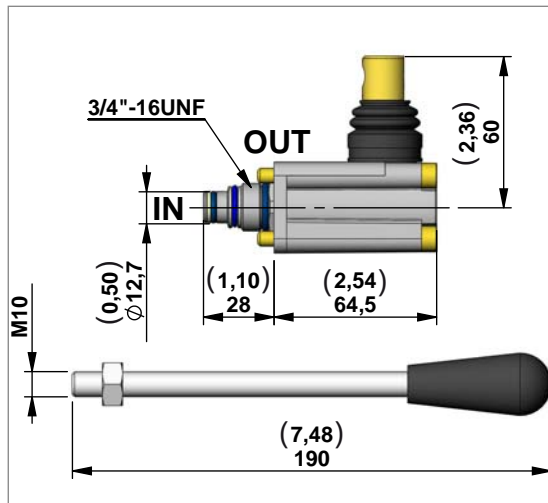

Type	Material Number		
K250113000	R932002448		
Technical Data			
General			
Max. working pressure	bar (psi) 300 (4500)		
Displacement	cc 1,5		
Hand pump (1.5cc)			
Code	Diagram	Type with lever	Material Number with lever
PMC12		K01V388540LV190	R932009298

**Plug for Cavity**

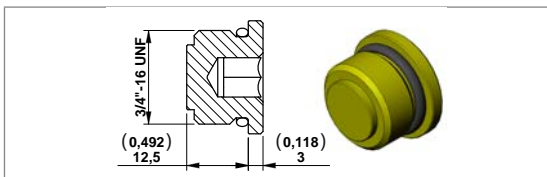

Code	Type	Material Number
TC4	R3897TA226	R932003201

**Plug for Cavity**

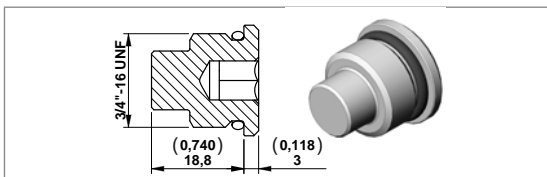

Code	Type	Material Number
TC3	R3897TA301	R932003211

**Plug for Cavity**

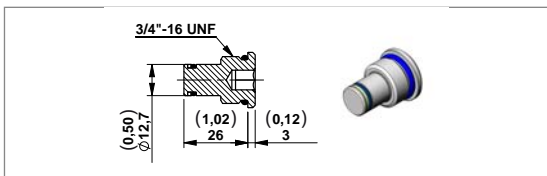

Code	Diagram	Compatibility	Type	Material Number
TC2		K - KE	R3897TA001	R932003193

**1/4" Auxiliary Return Port**

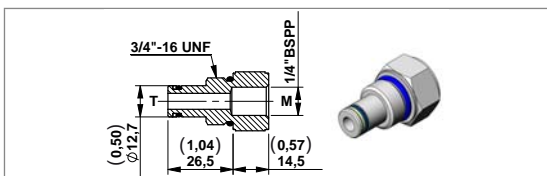

Code	Diagram	Compatibility	Type	Material Number
TS2		K - KE	R3897TA304	R932003214

**3/8" Auxiliary Return Port**

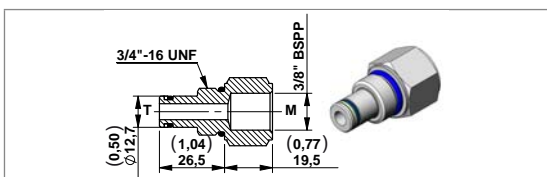

Code	Diagram	Compatibility	Type	Material Number
TS3		K - KE	R3897TA147	R932003195

**1/4" Auxiliary Pressure Port**

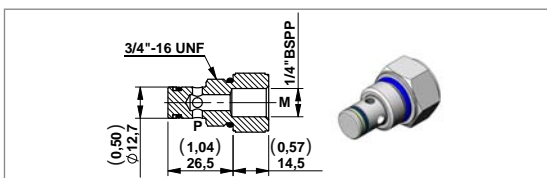

Code	Diagram	Compatibility	Type	Material Number
TM2		K - KE	R3897TA305	R932003215

**1/4" Auxiliary Pressure Port**

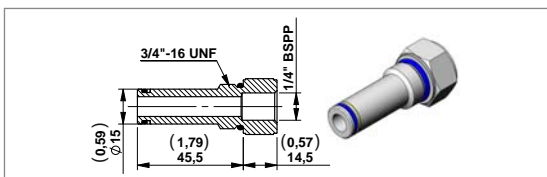

Code	Diagram	Compatibility	Type	Material Number
TM3		K - KE	R3897TA303	R932003213

**3/8" Auxiliary Pressure Port**

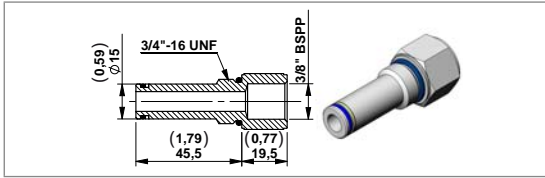

Code	Diagram	Compatibility	Type	Material Number
TM4		K - KE	R3897TA311	R932003220

**Check Valve with Pressure Port 1/4" BSPP for manifolds K series**

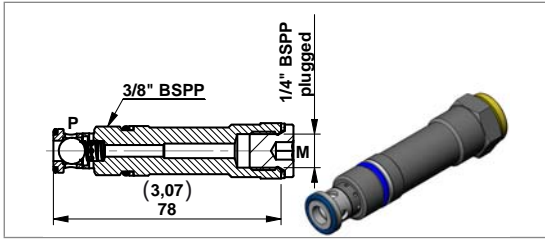

Code	Diagram	Compatibility	Type	Material Number
TPR		K	V389259000	R932003782

**Pressure Compensated Flow Regulator**

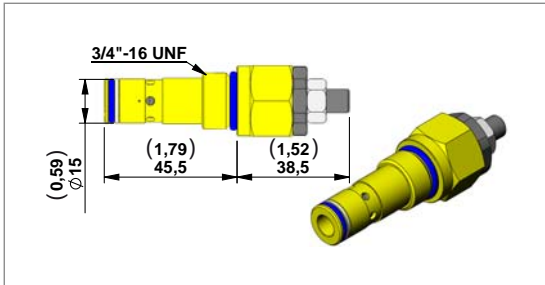

Code	Diagram	Type	Material Number
ST6CP-PR		K - KE	V389534A00

**Technical Data**

General			
Max. working pressure	bar (psi)	250 (3625)	
Regulated Flow Rate	l/min (gpm)	2....16 (0.53...4.23)	

**Flow Control Valves Pressure Compensated**

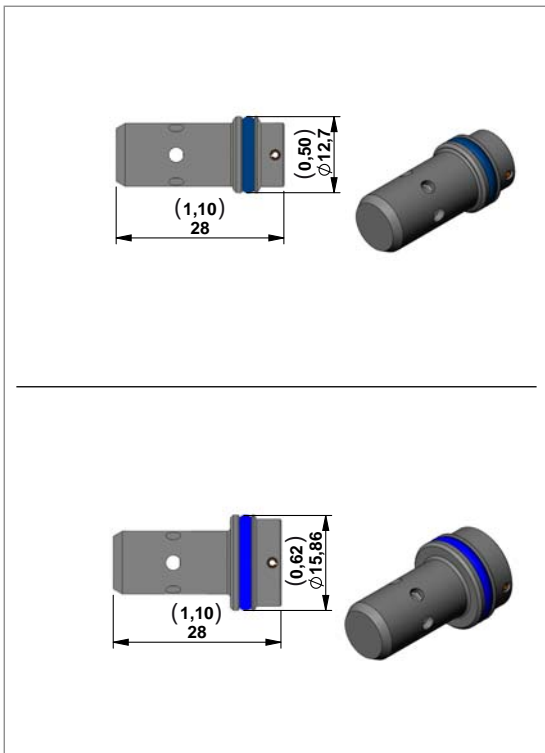

Code		l/min (gpm)	Diagram	Compatibility	Type	Material Number			
<b>STF12P</b>	A	1 (0,3)		K - KE	V38953600A	R932003940			
	B	2 (0,5)			V38953600B	R932003941			
	C	3 (0,8)			V38953600C	R932003942			
	D	4 (1,1)			V38953600D	R932003943			
	E	5 (1,3)			V38953600E	R932003944			
	F	6 (1,6)			V38953600F	R932003945			
	G	7 (1,9)			V38953600G	R932003946			
	H	8 (2,1)			V38953600H	R932003947			
	I	9 (2,4)			V38953600I	R932003948			
	L	10 (2,6)			V38953600L	R932003949			
	<b>STF14P</b>	A			1 (0,3)		KE - KS	V38951900A	R932003892
		B			2 (0,5)			V38951900B	R932003894
C		3 (0,8)	V38951900C	R932003895					
D		4 (1,1)	V38951900D	R932003896					
E		5 (1,3)	V38951900E	R932003897					
F		6 (1,6)	V38951900F	R932003898					
G		7 (1,9)	V38951900G	R932003899					
H		8 (2,1)	V38951900H	R932003900					
I		9 (2,4)	V38951900I	R932003901					
L		10 (2,6)	V38951900L	R932003903					

**Flow Control Valves Pressure Compensated**

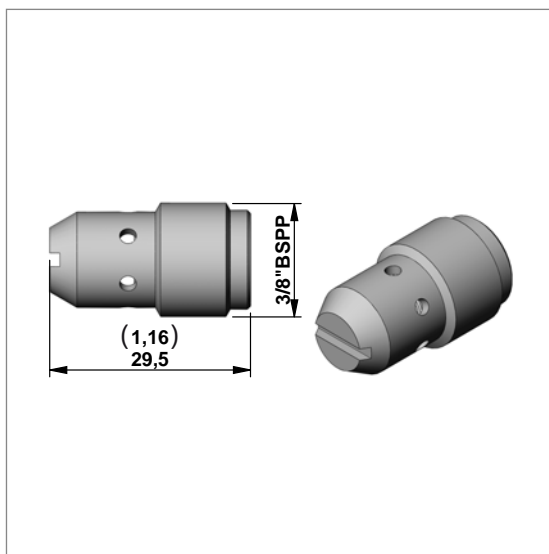

Code	l/min (gpm)	Diagram	Compatibility	Type	Material Number
<b>STF38</b>	B 2 (0,5)		KE	V38951500B	R932003860
	C 3 (0,8)			V38951500C	R932003861
	D 4 (1,1)			V38951500D	R932003862
	E 5 (1,3)			V38951500E	R932003864
	F 6 (1,6)			V38951500F	R932003866
	G 7 (1,9)			V38951500G	R932003868
	H 8 (2,1)			V38951500H	R932003870
	I 9 (2,4)			V38951500I	R932003872
	L 10 (2,6)			V38951500L	R932003876
	M 11 (2,9)			V38951500M	R932003877
	N 12 (3,2)			V38951500N	R932003878
	O 13 (3,4)			V38951500O	R932003879
	P 14 (3,7)			V38951500P	R932003880
	Q 15 (4,0)			V38951500Q	R932003881
	R 16 (4,2)			V38951500R	R932003882
	T 18 (4,7)			V38951500T	R932003884
	Z 20 (5,3)			V38951500Z	R932003888

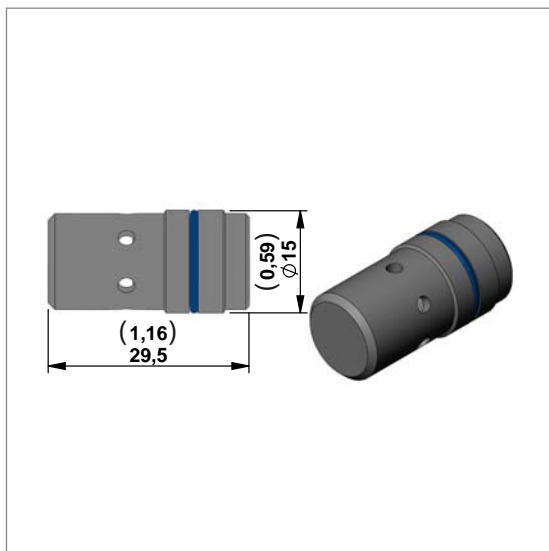

Code	l/min (gpm)	Diagram	Compatibility	Type	Material Number
<b>STF38P</b>	B 2 (0,5)		K - KE	V38953500B	R932003918
	C 3 (0,8)			V38953500C	R932003919
	D 4 (1,1)			V38953500D	R932003920
	E 5 (1,3)			V38953500E	R932003921
	F 6 (1,6)			V38953500F	R932003922
	G 7 (1,9)			V38953500G	R932003923
	H 8 (2,1)			V38953500H	R932003924
	I 9 (2,4)			V38953500I	R932003925
	L 10 (2,6)			V38953500L	R932003927
	M 11 (2,9)			V38953500M	R932003928
	N 12 (3,2)			V38953500N	R932003929
	O 13 (3,4)			V38953500O	R932003930
	P 14 (3,7)			V38953500P	R932003932
	Q 15 (4,0)			V38953500Q	R932003933
	R 16 (4,2)			V38953500R	R932003934
	T 18 (4,7)			V38953500T	R932003935
	Z 20 (5,3)			V38953500Z	R932003938

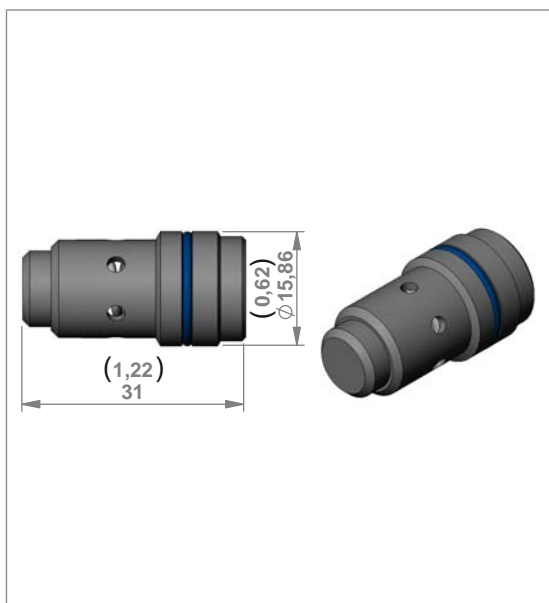

Code	l/min (gpm)	Diagram	Compatibility	Type	Material Number
<b>STF 38PKS</b>	B 2 (0,5)		KS00	V38955300B	R930052912
	C 3 (0,8)			V38955300C	R930052913
	D 4 (1,1)			V38955300D	R930052914
	E 5 (1,3)			V38955300E	R932004010
	F 6 (1,6)			V38955300F	R930046482
	G 7 (1,9)			V38955300G	R930052915
	H 8 (2,1)			V38955300H	R930052916
	I 9 (2,4)			V38955300I	R932004011
	L 10 (2,6)			V38955300L	R930052917
	M 11 (2,9)			V38955300M	R930052920
	N 12 (3,2)			V38955300N	R932004013
	O 13 (3,4)			V38955300O	R930046484
	P 14 (3,7)			V38955300P	R932004015
	Q 15 (4,0)			V38955300Q	R932004016
	R 16 (4,2)			V38955300R	R930052918
	T 18 (4,7)			V38955300T	R932004020
	Z 20 (5,3)			V38955300Z	R930052919

## Gear Pumps Group 1 for KE - K - KS

### Standard Version

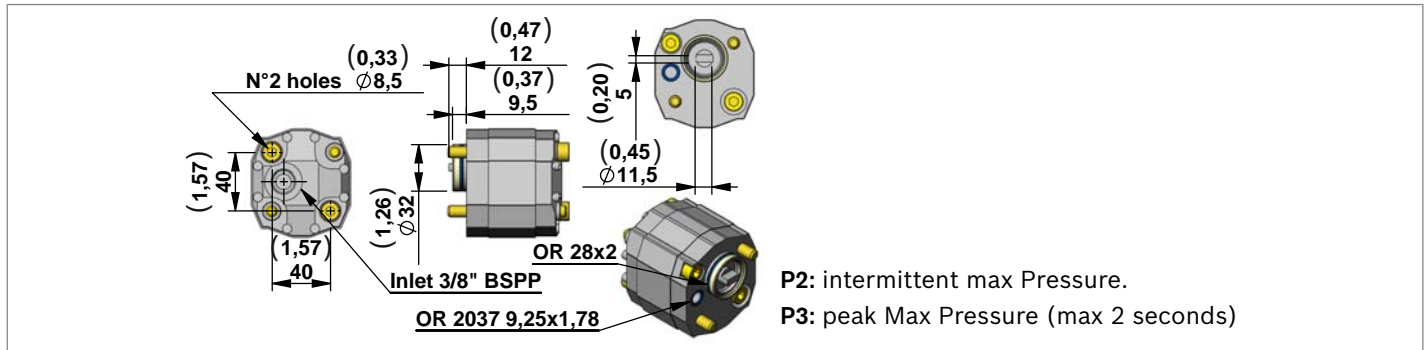

Code	Displacement cc/rev	Flow at 1500 rpm l/min (gpm)	P2 bar (psi)	P3 bar (psi)	Type	Material Number
10	0,9	1,35 (0,36)	230(3336)	270(3916)	K01CV640S1248	R932009230
11	1,1	1,65 (0,44)	230(3336)	270(3916)	K01CV640S1204	R932009231
12	1,6	2,4 (0,63)	230(3336)	270(3916)	K01CV10110322	R932007475
13	2	3 (0,79)	230(3336)	270(3916)	K01CV10110323	R932007477
14	2,5	3,75 (0,99)	230(3336)	270(3916)	K01CV10112317	R932007479
15	3,15	4,7 (1,24)	210(3046)	250(3626)	K01CV10112318	R932007481
16	4	6 (1,58)	210(3046)	250(3626)	K01CV10114321	R932007483

### High Pressure Gear Pumps Group 1 for KE - K - KS

#### Cast iron covers version for high pressure applications

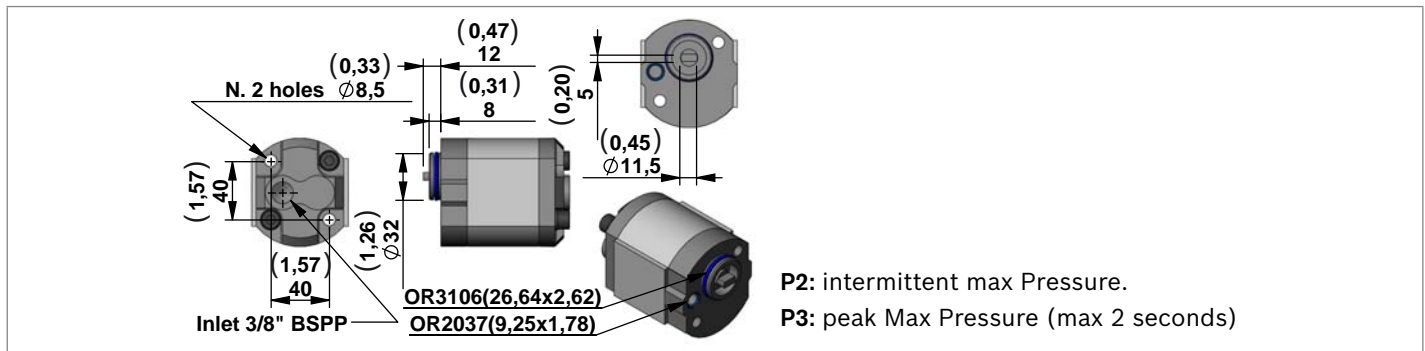

Code	Displacement cc/rev	Flow at 1500 rpm l/min (gpm)	P2 bar (psi)	P3 bar (psi)	Type	Material Number
11GH	1,25	1,8 (0,48)	300(4351)	350(5076)	K01CV640S1142C	R932007474
12GH	1,6	2,4 (0,63)	300(4351)	350(5076)	K01CV640S1144C	R932007476
13GH	2	3 (0,79)	300(4351)	350(5076)	K01CV640S1145C	R932007478
14GH	2,5	3,7 (0,98)	300(4351)	350(5076)	K01CV640S1146C	R932007480
15GH	3,15	4,7 (1,24)	280(4061)	330(4786)	K01CV640S1147C	R932007482
16GH	3,65	5,5 (1,45)	250(3626)	300(4351)	K01CV640S1148C	R932007484
17GH	4,2	6,3 (1,66)	230(3336)	280(4061)	K01CV640S1149C	R932007485
18GH	5	7,5 (1,98)	210(3046)	250(3626)	K01CV640S1150C	R932007486
19GH	5,7	8,5 (2,24)	210(3046)	250(3626)	K01CV640S1153C	R932007487
20GH	7,4	11,1 (2,93)	180(2611)	230(3336)	K01CV640S1152C	R932007488

#### Note

All pumps have anti-clockwise rotation.

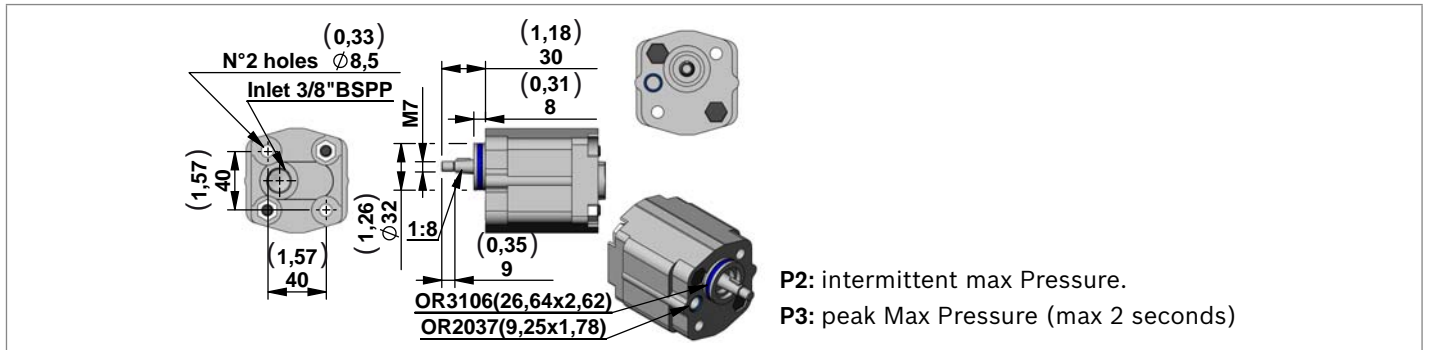

**Gear Pumps Group 1 for K****Elastic couplings version with tapered shaft\***

Code	Displacement cc/rev	Flow at 1500 rpm l/min (gpm)	P2 bar (psi)	P3 bar (psi)	Type	Material Number
<b>10CON</b>	0,82	1,3 (0,34)	230(3336)	270(3916)	K01CV640S1132	R932007498
<b>11CON</b>	1,1	1,6 (0,42)	230(3336)	270(3916)	K01CV64017000	R932007499
<b>12CON</b>	1,6	2,4 (0,63)	230(3336)	270(3916)	K01CV64018000	R932007500
<b>13CON</b>	2,1	3,1 (0,82)	230(3336)	270(3916)	K01CV64019000	R932007501
<b>14CON</b>	2,7	3,9 (1,03)	230(3336)	270(3916)	K01CV64020000	R932007502
<b>15CON</b>	3,2	4,8 (1,27)	210(3046)	250(3626)	K01CV64021000	R932007503
<b>16CON</b>	3,7	5,5 (1,45)	210(3046)	250(3626)	K01CV64022000	R932007504
<b>17CON</b>	4,2	6,3 (1,66)	210(3046)	250(3626)	K01CV64023000	R932007505
<b>18CON</b>	4,8	7,2 (1,90)	190(2756)	230(3336)	K01CV64024000	R932007506
<b>19CON</b>	5,8	8,7 (2,30)	190(2756)	230(3336)	K01CV64025000	R932007507
<b>20CON</b>	7,9	11,8 (3,12)	160(2320)	200(2901)	K01CV64026000	R932007508

**\*Note**

The assembly of the gear pumps with tapered shaft are only possible in the manifolds K series with the following junction elements:

- Motor size IEC71: junction element code F82
- Motor size IEC80: junction element code F24
- Motor size IEC90: junction element code F25
- Motor size IEC100-112: junction element code F26

## Oil Tanks for KE - K - KS

### Technical Data for Plastic Tanks

Temperature range	°C (°F)	-15....+70 (5....158)
Materials	PE=Polyethylene - PP=Polypropilene	
Seal	For tanks codes S335-S336-S337-S338-S339-S340-S341-S342 is necessary to use the O-RING Ø112x3 Code: C000191000 R-Number:R932000190. For all the other tanks except the codes above is necessary to use the O-RING 4437 (Ø110,7x3,53) Code:110201203000000 R-Number:R932000188	

Code	Tank capacity I (USgal)	Useable capacity I (USgal)	L mm (inch)	Material	Type	Material Number	Drawing
S335	1,0 (0,26)	0,7 (0,18)	140 (5,51)	PP	K01K3976SE372	R932002035	
S336	1,8 (0,48)	1,2 (0,32)	180 (7,09)	PP	K01K3976SE373	R932002036	
S337	2,5 (0,66)	1,7 (0,45)	240 (9,45)	PP	K01K3976SE374	R932002037	
S338	3,0 (0,79)	2,3 (0,61)	285 (11,22)	PP	K01K3976SE375	R932002038	

For this tanks is necessary to use the O-RING Ø112x3 code: C000191000 R-Number: R932000190

Code	Tank capacity I (USgal)	Useable capacity I (USgal)	H mm (inch)	Material	Type	Material Number	Drawing
S339	1,0 (0,26)	0,6 (0,16)	140 (5,51)	PP	K01K3976SE376	R932007882	
S340	1,8 (0,48)	1,1 (0,29)	180 (7,09)		K01K3976SE377	R932007883	
S341	2,5 (0,66)	1,7 (0,45)	240 (9,45)		K01K3976SE378	R932007884	
S342	3,0 (0,79)	2,3 (0,61)	285 (11,22)		K01K3976SE379	R932007885	

For this tanks is necessary to use the O-RING Ø112x3 code: C000191000 R-Number: R932000190

Code	Tank capacity I (USgal)	Useable capacity I (USgal)	-	Material	Type	Material Number	Drawing
S246	1 (0,26)	0,9 (0,24)	-	PE	K01K3976SE270	R932002016	

Code	Tank capacity I (USgal)	Useable capacity I (USgal)	L mm (inch)	Material	Type	Material Number	Drawing
S247	1,8 (0,48)	1,6 (0,42)	170 (6,71)	PE	K01K3976SE271	R932002017	
S248	2,5 (0,66)	2,2 (0,58)	240 (9,45)	PE	K01K3976SE272	R932002018	

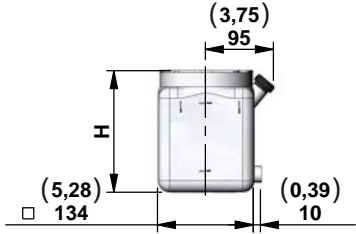

**Plastic Tanks**

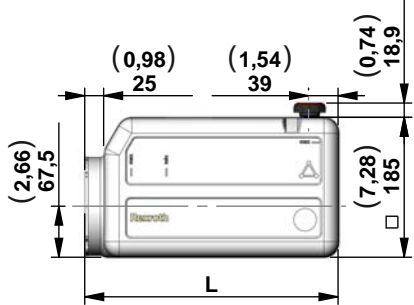
Code	Tank capacity l (USgal)	Useable capacity l (USgal)	H mm (inch)	Material	Type	Material Number	Drawing
<b>S249</b>	1 (0,26)	0,9 (0,24)	135 (5,31)	PE	K01K3976SE273	R932002019	
<b>S250</b>	1,8 (0,48)	1,6 (0,42)	170 (6,71)	PE	K01K3976SE274	R932002020	
<b>S251</b>	2,5 (0,66)	2,2 (0,58)	240 (9,45)	PE	K01K3976SE275	R932002021	

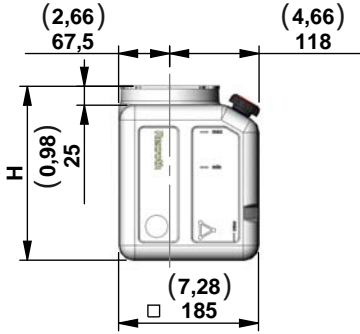
Code	Tank capacity l (USgal)	Useable capacity l (USgal)	L mm (inch)	Material	Type	Material Number	Drawing
<b>S343</b>	5 (1,32)	3,8 (1,00)	230 (9,05)	PE	K01K3976SE380	R932002039	
<b>S331</b>	5 (1,32)	3,8 (1,00)	230 (9,05)	PE <u>Black</u>	K01K3976SE368	R932007872	
<b>S413</b>	7 (1,85)	5,5 (1,45)	310 (12,20)	PE	K01K3976SE439	R932007873	
<b>S414</b>	7 (1,85)	5,5 (1,45)	310 (12,20)	PE <u>Black</u>	K01K3976SE440	R932007874	
<b>S415</b>	8 (2,11)	6,5 (1,72)	335 (13,19)	PE	K01K3976SE441	R932006036	
<b>S416</b>	8 (2,11)	6,5 (1,72)	335 (13,19)	PE <u>Black</u>	K01K3976SE442	R932007875	
<b>S316</b>	9 (2,38)	7,3 (1,93)	365 (14,37)	PE	K01K3976SE351	R932002031	
<b>S314</b>	9 (2,38)	7,3 (1,93)	365 (14,37)	PE <u>Black</u>	K01K3976SE451	R932007876	
<b>S417</b>	12 (3,17)	10 (2,64)	495 (19,50)	PE	K01K3976SE443	R932006768	
<b>S418</b>	12 (3,17)	10 (2,64)	495 (19,50)	PE <u>Black</u>	K01K3976SE444	R932007877	

Code	Tank capacity l (USgal)	Useable capacity l (USgal)	H mm (inch)	Material	Type	Material Number	Drawing
<b>S344</b>	5 (1,32)	3,5 (0,92)	230 (9,05)	PE	K01K3976SE381	R932002040	
<b>S332</b>	5 (1,32)	3,5 (0,92)	230 (9,05)	PE <u>Black</u>	K01K3976SE369	R932008240	
<b>S419</b>	7 (1,85)	5,5 (1,45)	310 (12,20)	PE	K01K3976SE445	R932007879	
<b>S420</b>	7 (1,85)	5,5 (1,45)	310 (12,20)	PE <u>Black</u>	K01K3976SE446	R932007880	
<b>S421</b>	8 (2,11)	6,5 (1,72)	335 (13,19)	PE	K01K3976SE447	R932006037	
<b>S422</b>	8 (2,11)	6,5 (1,72)	335 (13,19)	PE <u>Black</u>	K01K3976SE448	R932007881	
<b>S315</b>	9 (2,38)	7,3 (1,93)	365 (14,37)	PE	K01K3976SE350	R932002030	
<b>S313</b>	9 (2,38)	7,3 (1,93)	365 (14,37)	PE <u>Black</u>	K01K3976SE348	R932002029	
<b>S423</b>	12 (3,17)	10 (2,64)	495 (19,50)	PE	K01K3976SE449	R932006038	
<b>S424</b>	12 (3,17)	10 (2,64)	495 (19,50)	PE <u>Black</u>	K01K3976SE450	R932006278	

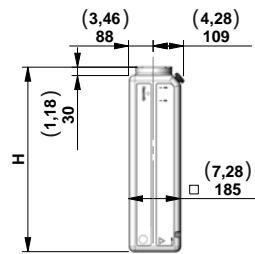
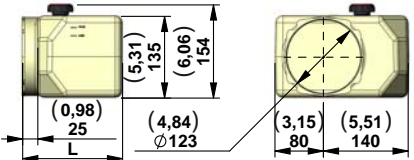
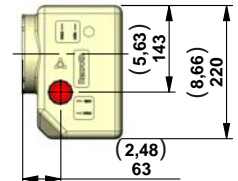
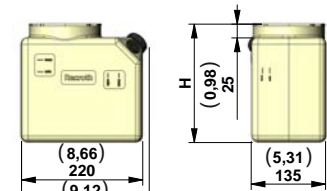
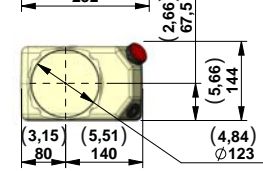
**Plastic Tanks**

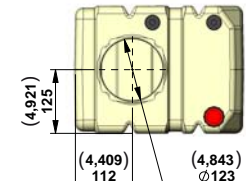
Code	Tank capacity l (USgal)	Useable capacity l (USgal)	H mm (inch)	Material	Type	Material Number	Drawing
<b>S428</b>	15 (3,96)	13 (3,43)	595 (23,42)	PE <u>Black</u>	K01K3976SE456	R932009317	
<b>S430</b>	17 (4,50)	15 (3,96)	660 (25,98)	PE	K01K3976SE459	R932009316	
<b>S429</b>	17 (4,50)	15 (3,96)	660 (25,98)	PE <u>Black</u>	K01K3976SE457	R932008291	
Code	Tank capacity l (USgal)	Useable capacity l (USgal)	L mm (inch)	Material	Type	Material Number	Drawing
<b>S395</b>	3 (0,79)	1,7 (0,45)	140 (5,51)	PE	K01K3976SE470	R932007903	
<b>S396</b>	3,7 (0,98)	2,2 (0,58)	165 (6,50)	PE	K01K3976SE471	R932007904	
<b>S392</b>	5 (1,32)	3,1 (0,82)	215 (8,46)	PE	K01K3976SE464	R932007365	
<b>S394</b>	8,4 (2,22)	5,5 (1,45)	340 (13,39)	PE	K01K3976SE466	R932007435	
<b>S397</b>	12,7 (3,35)	8,4 (2,2)	500 (19,68)	PE	K01K3976SE472	R932007905	
Code	Tank capacity l (USgal)	Useable capacity l (USgal)	H mm (inch)	Material	Type	Material Number	Drawing
<b>S434</b>	3 (0,79)	1,7 (0,45)	140 (5,51)	PE	K01K3976SE478	R932007910	
<b>S435</b>	3,7 (0,98)	2,2 (0,58)	165 (6,50)	PE	K01K3976SE479	R932007911	
<b>S436</b>	5 (1,32)	3,1 (0,82)	215 (8,46)	PE	K01K3976SE480	R932007912	
<b>S437</b>	8,4 (2,22)	5,5 (1,45)	340 (13,39)	PE	K01K3976SE481	R932007913	
<b>S438</b>	12,7 (3,35)	8,4 (2,2)	500 (19,68)	PE	K01K3976SE482	R932007914	
<b>S442</b>	10 (2,64)	7 (1,85)	190 (7,18)	PE	K01K3976SE492	R932010792	
<b>S443</b>	12 (3,17)	9 (2,38)	215 (8,46)	PE	K01K3976SE493	R932010793	
<b>S444</b>	15 (3,96)	12,5 (3,30)	265 (10,43)	PE	K01K3976SE494	R932010794	
<b>S445</b>	20 (5,28)	17,5 (4,62)	330 (12,99)	PE	K01K3976SE495	R932010795	

**Plastic Tanks**

Code	Tank capacity l (USgal)	Useable capacity l (USgal)	L mm (inch)	Material	Type	Material Number	Drawing
S374	5 (1,32)	4 (1,06)	219 (8,62)	PE	K01K3976SE415	R932002042	
S376	7 (1,85)	5,4 (1,43)	271 (10,67)		K01K3976SE417	R932002044	
S378	8 (2,11)	6,6 (1,74)	323 (12,72)		K01K3976SE419	R932002046	
S380	11 (2,91)	9,6 (2,54)	453 (17,83)		K01K3976SE421	R932002048	

Code	Tank capacity l (USgal)	Useable capacity l (USgal)	H mm (inch)	Material	Type	Material Number	Drawing
S375	5 (1,32)	4 (1,06)	219 (8,62)	PE	K01K3976SE416	R932002043	
S377	7 (1,85)	5,4 (1,43)	271 (10,67)		K01K3976SE418	R932002045	
S379	8 (2,11)	6,6 (1,74)	323 (12,72)		K01K3976SE420	R932002047	
S381	11 (2,91)	9,6 (2,54)	453 (17,83)		K01K3976SE422	R932002049	

**Assembly Kit for Plastic Tank**

Oil Tank	Code for KE	Material Number	Please make sure that the tank and motor are mounted correctly
S335 - S336 - S337 - S338 - S339 - S340 S341 - S342	K2501VT006	R932002436	
S246 - S247 - S248 - S249 - S250 - S251	K2501VT007	R932002437	
S413 - S414 - S419 - S420 - S415 - S416 - S421 - S422 - S332 - S344 - S313 - S315 - S343 - S331 - S316 - S314 - S374 - S375 - S376 - S377 - S378 - S379 - S380 - S381 - S417 - S418 - S423 - S424 - S395 - S396 - S392 - S394 - S397 - S434 - S435 - S436 - S437 - S438 - S428 - S430 - S429 - S442 - S443 - S444 - S445	K2501VT014	R932002440	
Oil Tank	Code for K	Material Number	
S335 - S336 - S337 - S338 - S339 - S340 S341 - S342	K2501VT001	R932002433	
S246 - S247 - S248 - S249 - S250 - S251	K2501VT002	R932002434	
S413 - S414 - S419 - S420 - S415 - S416 - S421 - S422 - S332 - S344 - S313 - S315 - S343 - S331 - S316 - S314 - S374 - S375 - S376 - S377 - S378 - S379 - S380 - S381 - S417 - S418 - S423 - S424 - S395 - S396 - S392 - S394 - S397 - S434 - S435 - S436 - S437 - S438 - S428 - S430 - S429 - S442 - S443 - S444 - S445	K2501VT013	R932002439	
Oil Tank	Code for KS	Material Number	
S335 - S336 - S337 - S338 - S339 - S340 S341 - S342	K2501VT016	R932007391	
S246 - S247 - S248 - S249 - S250 - S251	K2501VT015	R932008244	
S413 - S414 - S419 - S420 - S415 - S416 - S421 - S422 - S332 - S344 - S313 - S315 - S343 - S331 - S316 - S314 - S374 - S375 - S376 - S377 - S378 - S379 - S380 - S381 - S417 - S418 - S423 - S424 - S395 - S396 - S392 - S394 - S397 - S434 - S435 - S436 - S437 - S438 - S428 - S430 - S429 - S442 - S443 - S444 - S445	K2501VT026	R930053718	

## Oil Tanks for KE - K

### Technical Data for Steel Tanks

Temperature range	°C (°F)	-15....+80 (5....176)
Materials		Steel
Colors		Black paint finish
Seal		For all the steel tanks is necessary to use the O-RING 4437 (Ø110,7x3,53) Code:110201203000000 - R-Number:R932000188

### Steel collar for Tanks

Code	Type	Material Number	Drawing
S00	K224201000	R932006279	

### Steel Tanks

Code	Tank capacity l (USgal)	Useable capacity l (USgal)	L mm (inch)	A mm (inch)	Type	Material Number	Drawing
S01	1 (0,26)	0,7 (0,18)	133 (5,24)	35 (1,38)	K01K3976SE001	R932001937	
S20	1,8 (0,48)	1,2 (0,32)	178 (7,01)	35 (1,38)	K01K3976SE026	R932001953	
S02	2,5 (0,66)	1,7 (0,45)	238 (9,37)	60 (2,36)	K01K3976SE003	R932001939	
S161	3 (0,79)	2,3 (0,61)	280 (11,02)	60 (2,36)	K01K3976SE186	R932001987	
S107	4 (1,06)	3,2 (0,84)	409 (16,10)	60 (2,36)	K01K3976SE119	R932001970	

Code	Tank capacity l (USgal)	Useable capacity l (USgal)	L mm (inch)	A mm (inch)	Type	Material Number	Drawing
S144	1,8 (0,48)	1,2 (0,32)	178 (7,01)	35 (1,38)	K01K3976SE168	R932001983	
S142	2,5 (0,66)	1,7 (0,45)	238 (9,37)	60 (2,36)	K01K3976SE166	R932001981	

Code	Tank capacity l (USgal)	Useable capacity l (USgal)	H mm (inch)	A mm (inch)	Type	Material Number	Drawing
S216	1 (0,26)	0,6 (0,16)	133 (5,24)	35 (1,38)	K01K3976SE246	R932002011	
S217	1,8 (0,48)	1,1 (0,29)	178 (7,01)	35 (1,38)	K01K3976SE247	R932002012	
S218	2,5 (0,66)	1,7 (0,45)	238 (9,37)	60 (2,36)	K01K3976SE248	R932009269	
S239	3 (0,79)	2,3 (0,61)	280 (11,02)	60 (2,36)	K01K3976SE269	R932002015	
S107V	4 (1,06)	3,2 (0,84)	409 (16,10)	60 (2,36)	K01K3976SE161	R932001976	

**Steel Tanks**

Code	Tank capacity I (USgal)	Useable capacity I (USgal)	H mm (inch)	A mm (inch)	Type	Material Number	Drawing
------	-------------------------	----------------------------	-------------	-------------	------	-----------------	---------

<b>S20V</b>	1,8 (0,48)	1,1 (0,29)	178 (7,01)	35 (1,38)	K01K3976SE027	R932001954	
-------------	---------------	---------------	---------------	--------------	---------------	------------	--

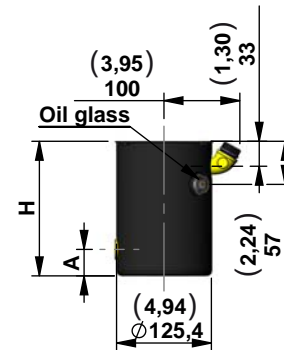

<b>S02V</b>	2,5 (0,66)	1,7 (0,45)	238 (9,37)	60 (2,36)	K01K3976SE004	R932001940	
-------------	---------------	---------------	---------------	--------------	---------------	------------	--

Code	Tank capacity I (USgal)	Useable capacity I (USgal)	L mm (inch)	-	Type	Material Number	Drawing
------	-------------------------	----------------------------	-------------	---	------	-----------------	---------

<b>S03</b>	5 (1,32)	4 (1,06)	219 (8,62)	-	K01K3976SE005	R932001941	
------------	-------------	-------------	---------------	---	---------------	------------	--

<b>S34</b>	7 (1,85)	5,4 (1,43)	271 (10,67)	-	K01K3976SE041	R932001956	
------------	-------------	---------------	----------------	---	---------------	------------	--

<b>S04</b>	8 (2,11)	6,6 (1,74)	323 (12,72)	-	K01K3976SE007	R932001943	
------------	-------------	---------------	----------------	---	---------------	------------	--

<b>S109</b>	11 (2,91)	9,6 (2,54)	453 (17,83)	-	K01K3976SE172	R932001985	
-------------	--------------	---------------	----------------	---	---------------	------------	--

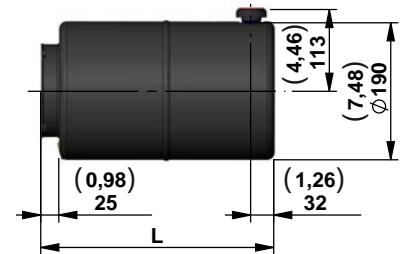

Code	Tank capacity I (USgal)	Useable capacity I (USgal)	H mm (inch)	-	Type	Material Number	Drawing
------	-------------------------	----------------------------	-------------	---	------	-----------------	---------

<b>S03V</b>	5 (1,32)	3 (7,9)	219 (8,62)	-	K01K3976SE006	R932001942	
-------------	-------------	------------	---------------	---	---------------	------------	--

<b>S34V</b>	7 (1,85)	4,4 (1,16)	271 (10,67)	-	K01K3976SE042	R932001957	
-------------	-------------	---------------	----------------	---	---------------	------------	--

<b>S04V</b>	8 (2,11)	5,8 (1,53)	323 (12,72)	-	K01K3976SE008	R932001944	
-------------	-------------	---------------	----------------	---	---------------	------------	--

<b>S109V</b>	11 (2,91)	9,0 (2,38)	453 (17,83)	-	K01K3976SE121	R932001972	
--------------	--------------	---------------	----------------	---	---------------	------------	--

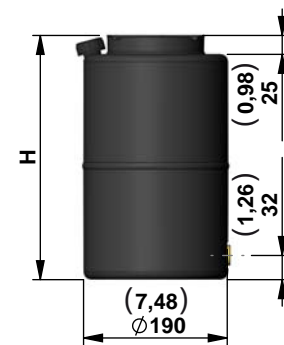

Code	Tank capacity I (USgal)	Useable capacity I (USgal)	-	-	Type	Material Number	Drawing
------	-------------------------	----------------------------	---	---	------	-----------------	---------

<b>S185</b>	5 (1,32)	3 (7,9)	-	-	K01K3976SE345	R932007057	
-------------	-------------	------------	---	---	---------------	------------	--

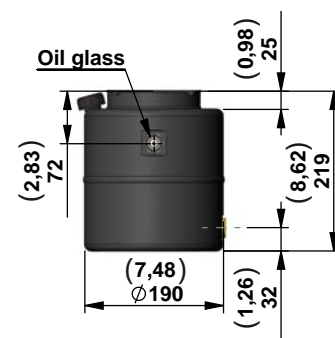

**Steel Tanks**

Code	Tank capacity l (USgal)	Useable capacity l (USgal)	Type	Material Number	Drawing
------	----------------------------	-------------------------------	------	--------------------	---------

**S106** 5 (1,32) 3 (7,9) K01K3976SE215 R932001997

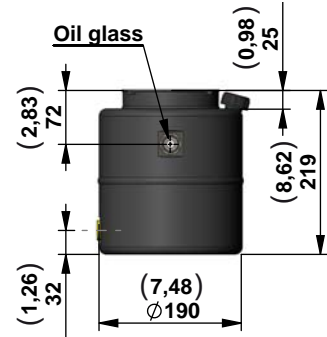

**S108** 8 (2,11) 5,8 (1,53) K01K3976SE120 R932001971

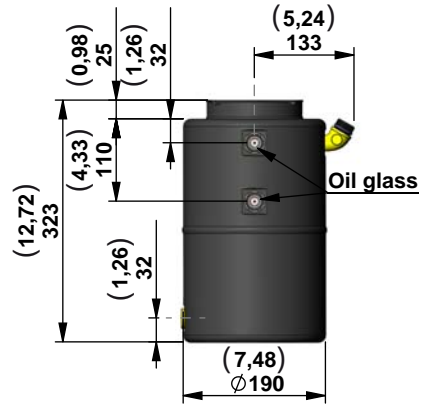

**S94** 8 (2,11) 6,6 (1,74) K01K3976SE106 R932001965

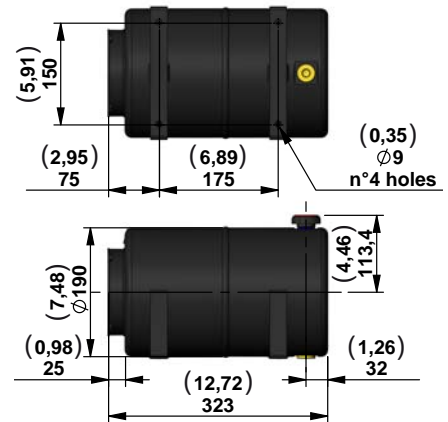

**S177** 9 (2,38) 7,7 (2,03) K01K3976SE207 R932001994

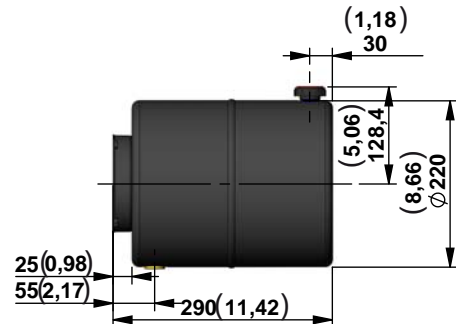



**Steel Tanks**

Code	Tank capacity l (USgal)	Useable capacity l (USgal)	Type	Material Number	Drawing
------	----------------------------	-------------------------------	------	--------------------	---------

**S178** 9 (2,38) 6,9 (1,82) K01K3976SE208 R932001995

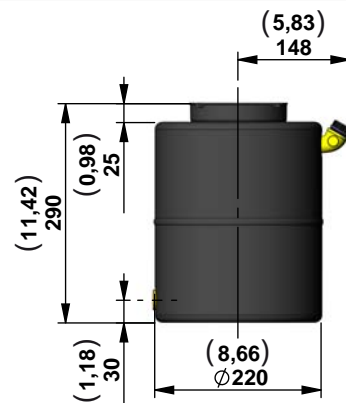

Code	Tank capacity l (USgal)	Useable capacity l (USgal)	A mm (inch)	B mm (inch)	C mm (inch)	L mm (inch)	Type	Material Number	Drawing
------	----------------------------	-------------------------------	----------------	----------------	----------------	----------------	------	--------------------	---------

**S90\*** 12 (3,17) 10,5 (2,77) 60 (2,36) 170 (6,69) 105 (4,13) 315 (12,40) K01K3976SE100 R932001961

**S128\*** 16 (4,23) 13 (3,43) 60 (2,36) 170 (6,69) 158 (6,22) 368 (14,49) K01K3976SE151 R932001975

**S105\*** 19 (5,02) 15 (3,96) 52,5 (2,07) 290 (11,42) 158 (6,22) 420 (16,53) K01K3976SE117 R932001969

**S92\*** 23 (6,08) 19 (5,02) 102,5 (4,03) 290 (11,42) 158 (6,22) 520 (20,47) K01K3976SE102 R932001962

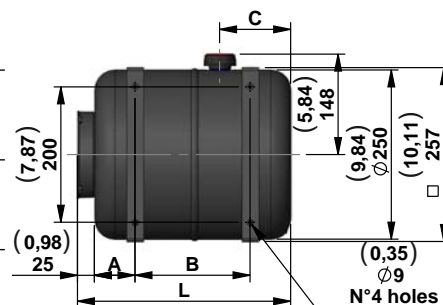

Code	Tank capacity l (USgal)	Useable capacity l (USgal)	H mm (inch)	A mm (inch)	B mm (inch)	Type	Material Number	Drawing
------	----------------------------	-------------------------------	----------------	----------------	----------------	------	--------------------	---------

**S90V\*** 12 (3,17) 9 (2,38) 315 (12,40) 60 (2,36) 170 (6,69) K01K3976SE103 R932001963

**S92V\*** 23 (6,08) 18 (4,75) 520 (20,47) 102,5 (4,03) 290 (11,42) K01K3976SE104 R932001964

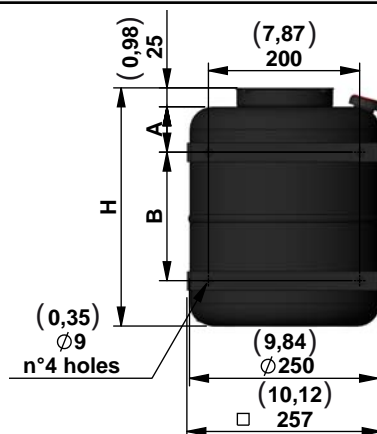

**\*Note**

In order to avoid to support the weight of motor by the collar of the tank when the tanks with fixing brackets are used, it is strongly suggested to support also the central manifold.

**Steel Tanks**

Code	Tank capacity l (USgal)	Useable capacity l (USgal)	Brackets	Type	Material Number	Drawing	
<b>S07</b>	6 (1,58)	4 (1,06)	No	K01K3976SE013	R932001945		
<b>S138*</b>	6 (1,58)	4 (1,06)	Yes	K01K3976SE162	R932001977		
<b>S48</b>	6 (1,58)	4 (1,06)	No	K01K3976SE056	R932001959		
<b>S139*</b>	6 (1,58)	4 (1,06)	Yes	K01K3976SE163	R932001978		
Code	Tank capacity l (USgal)	Useable capacity l (USgal)	A mm (inch)	B mm (inch)	Type	Material Number	Drawing
<b>S223*</b>	8 (2,11)	6 (1,58)	156 (6,14)	131 (5,16)	K01K3976SE253	R932002013	
<b>S54</b>	12 (3,17)	9,5 (2,51)	210 (8,27)	186 (7,32)	K01K3976SE063	R932001960	
<b>S140*</b>	12 (3,17)	9,5 (2,51)	210 (8,27)	186 (7,32)	K01K3976SE164	R932001979	
<b>S256*</b>	14 (3,70)	12 (3,17)	235 (9,25)	211 (8,31)	K01K3976SE280	R932002022	
<b>S141*</b>	15 (3,96)	13 (3,43)	261 (10,28)	236 (9,29)	K01K3976SE165	R932001980	
<b>S143*</b>	20 (5,28)	18 (4,75)	329 (12,95)	305 (12,01)	K01K3976SE167	R932001982	

**\*Note**

In order to avoid to support the weight of motor by the collar of the tank when the tanks with fixing brackets are used, it is strongly suggested to support also the central manifold.

**Steel Tanks**

Code	Tank capacity I (USgal)	Useable capacity I (USgal)	Type	Material Number	Drawing
<b>S184*</b>	15 (3,96)	13 (3,43)	K01K3976SE214	R932001996	
<b>S189*</b>	15 (3,96)	13 (3,43)	K01K3976SE219	R932001998	

**\*Note**

In order to avoid to support the weight of motor by the collar of the tank when the tanks with fixing brackets are used, it is strongly suggested to support also the central manifold.

**Steel Tanks**

Code	Tank capacity l (USgal)	Useable capacity l (USgal)	A mm (inch)	B mm (inch)	C mm (inch)	L x W mm (inch)	Type	Material Number	Drawing
<b>S09</b>	20 (5,28)	12,5 (3,30)	285 (11,22)	53 (2,09)	207 (8,15)	340x270 (13,4x10,6)	K01K3976SE015	R932001946	
<b>S240</b>	20 (5,28)	12,5 (3,30)	285 (11,22)	53 (2,09)	207 (8,15)	340x270 (13,4x10,6)	K01K3976SE195	R932001989	
<b>S10</b>	30 (7,92)	22,5 (5,94)	405 (15,94)	58 (2,28)	322 (12,68)	340x270 (13,4x10,6)	K01K3976SE016	R932001947	
<b>S241</b>	30 (7,92)	22,5 (5,94)	405 (15,94)	58 (2,28)	322 (12,68)	340x270 (13,4x10,6)	K01K3976SE196	R932001990	
<b>S11</b>	45 (11,89)	30 (7,92)	344 (13,54)	58 (2,28)	261 (10,28)	540x320 (21,3x12,6)	K01K3976SE017	R932001948	
<b>S242</b>	45 (11,89)	30 (7,92)	344 (13,54)	58 (2,28)	261 (10,28)	540x320 (21,3x12,6)	K01K3976SE197	R932001991	
<b>S12</b>	60 (15,85)	44 (11,62)	435 (17,13)	58 (2,28)	352 (13,86)	540x320 (21,3x12,6)	K01K3976SE018	R932001949	
<b>S243</b>	60 (15,85)	44 (11,62)	435 (17,13)	58 (2,28)	352 (13,86)	540x320 (21,3x12,6)	K01K3976SE198	R932001992	

Code	Tank capacity l (USgal)	Useable capacity l (USgal)	A mm (inch)	B mm (inch)	Type	Material Number	Drawing
<b>S211</b>	3,5 (0,92)	3 (0,79)	125 (4,92)	100 (3,94)	K01K3976SE241	R932002009	
<b>S212</b>	8 (2,11)	7 (1,85)	245 (9,65)	220 (8,66)	K01K3976SE242	R932002010	



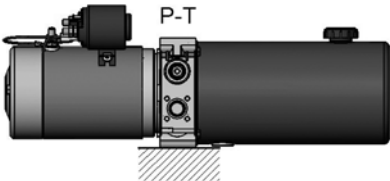
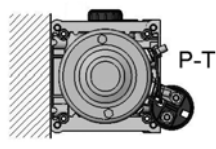
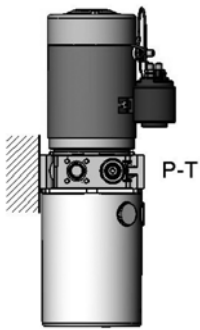
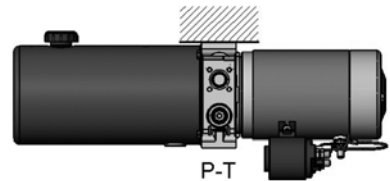
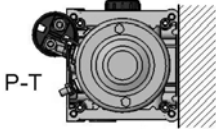
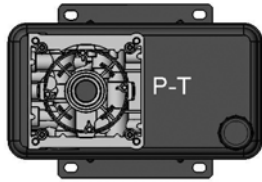
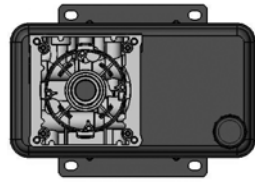
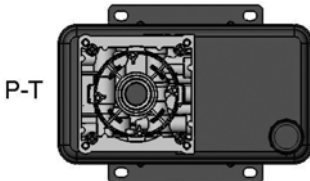
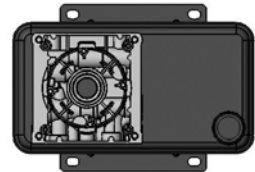

**Aluminium Tanks for KE - K**

Code	Tank capacity l (USgal)	Useable capacity l (USgal)	Type	Material Number	Drawing
<b>S31</b>	10 (2,64)	8,3 (2,19)	K01K3976SE038	R932001955	
<b>S245</b>	10 (2,64)	8,3 (2,19)	K01K3976SE199	R932001993	

## Mounting position

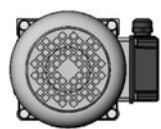
Code	Code	Code
01	03	V1
		
02	04	
		
-	06	
		
07	08	
		

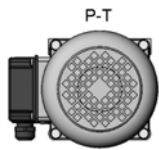
### Terminal Box Position for A.C. Motors

-	M2
	
M3	M4
	

### Relay Position for D.C. Motors

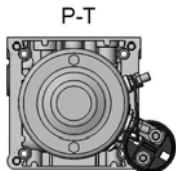
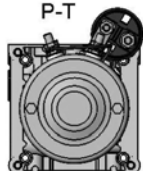
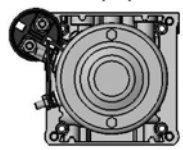
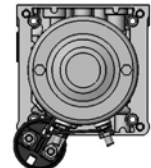
-	R2
	
R3	R4
	

**Oil Cap Position for V1 only**

Code	Code
-	LU
LO	LP

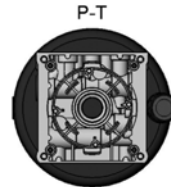
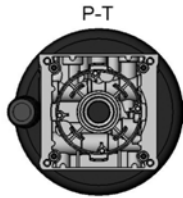
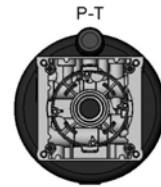

**Mounting Brackets**

**Support for Manifold KE Series**

Code	Central manifold	Type	Material number
G80	KE	K01F331514000	R932009395

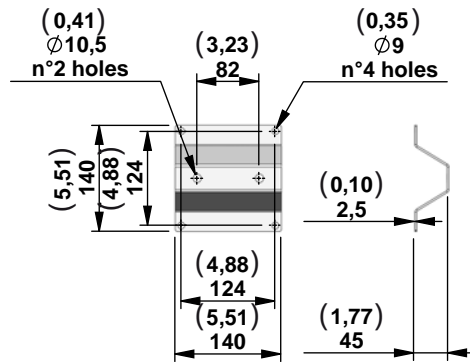

**Support for Manifold K Series**

Code	Central manifold	Type	Material number
G07	K	K01K331507000	R932009393
G07L	K	K01K331507000	R932009393

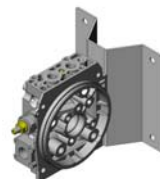
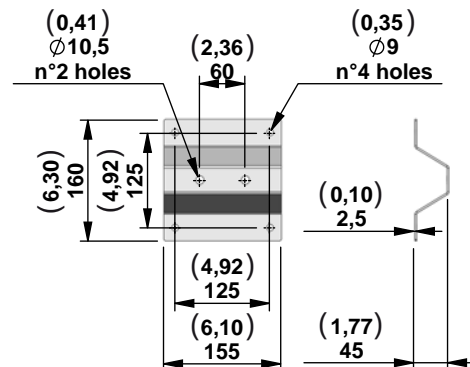

### Modular Stackable Elements

#### Space Modular Block

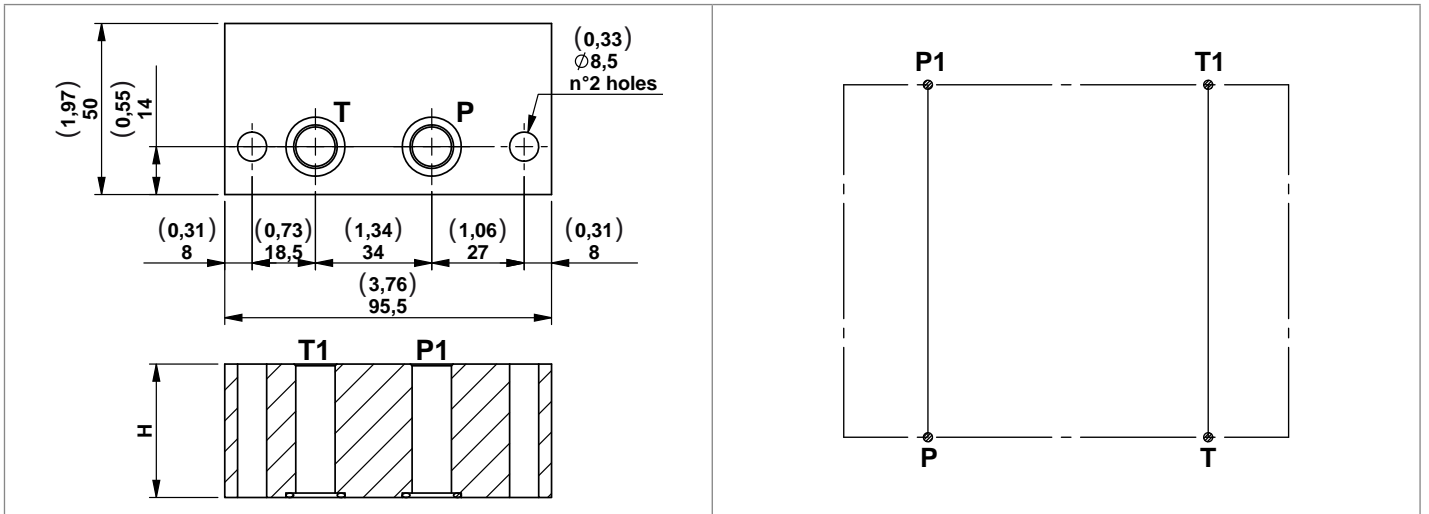

These modular blocks have been designed to have the ability to be assembled as a stack to allow clearance

between flanges and motors of different sizes and types. Each block includes 2 OR 3056 gaskets.

Code	Description	Max working pressure bar (psi)	Max flow l/min (gpm)	Type	Material number
N09	Space modular block H=18	300 (4351)	40 (10,57)	G386010000	R932001058
N01	Space modular block H=39	300 (4351)	40 (10,57)	G386001000	R932001005
N02	Space modular block H=69	300 (4351)	40 (10,57)	G386038000	R932001122

Motor IEC71 frame Coupling TR02

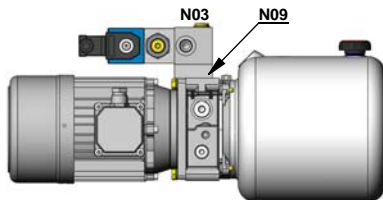

Motor IEC80 frame Coupling TR03

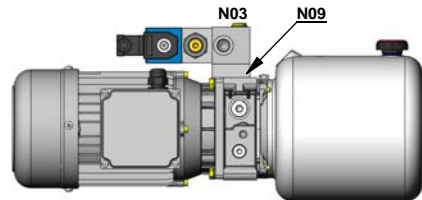

Motor IEC90 frame Coupling TR04

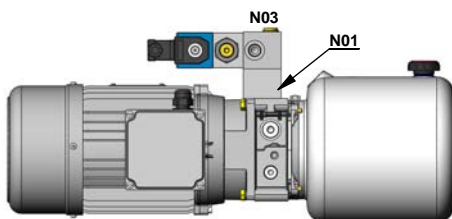

Motor IEC100 frame Coupling TR05

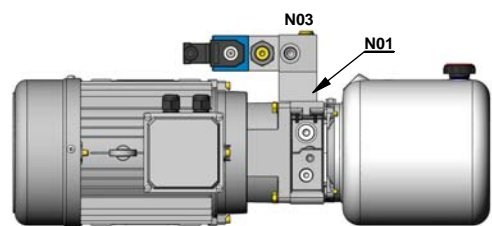

Motor IEC112 frame Coupling TR05

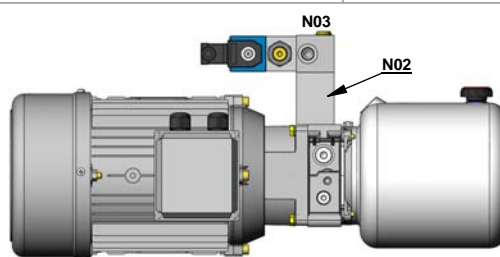

**Space Modular Block**

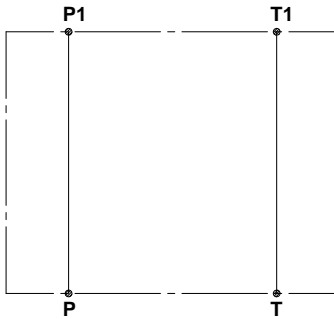
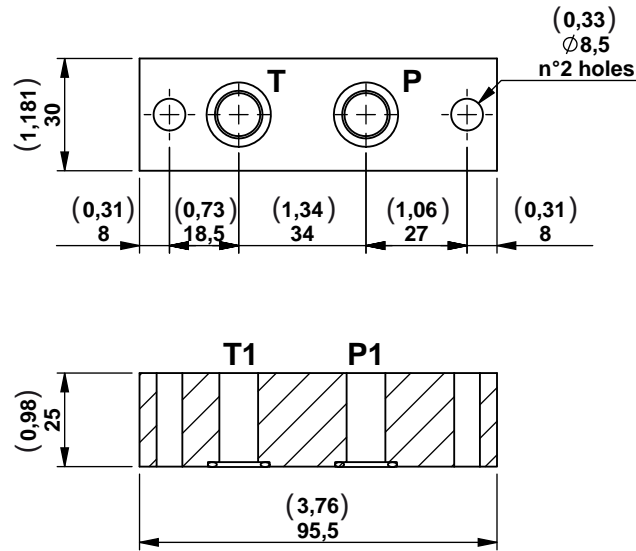

Space Modular Block to fix a compact mounting style electric motor on power module KE type.  
This block includes 2 OR 3056 gaskets.

Code	Description	Max working pressure bar (psi)	Max flow l/min (gpm)	Type	Material number
N92	Space modular block	300 (4351)	40 (10,57)	G386091000	R932001167

**Application Example**

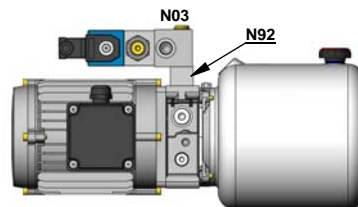



**90° Rotation modular block**

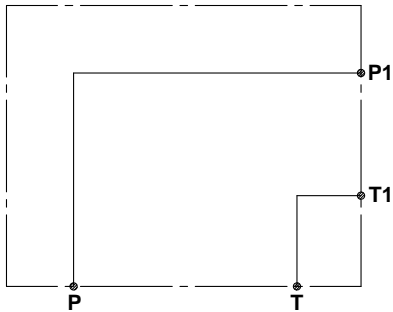
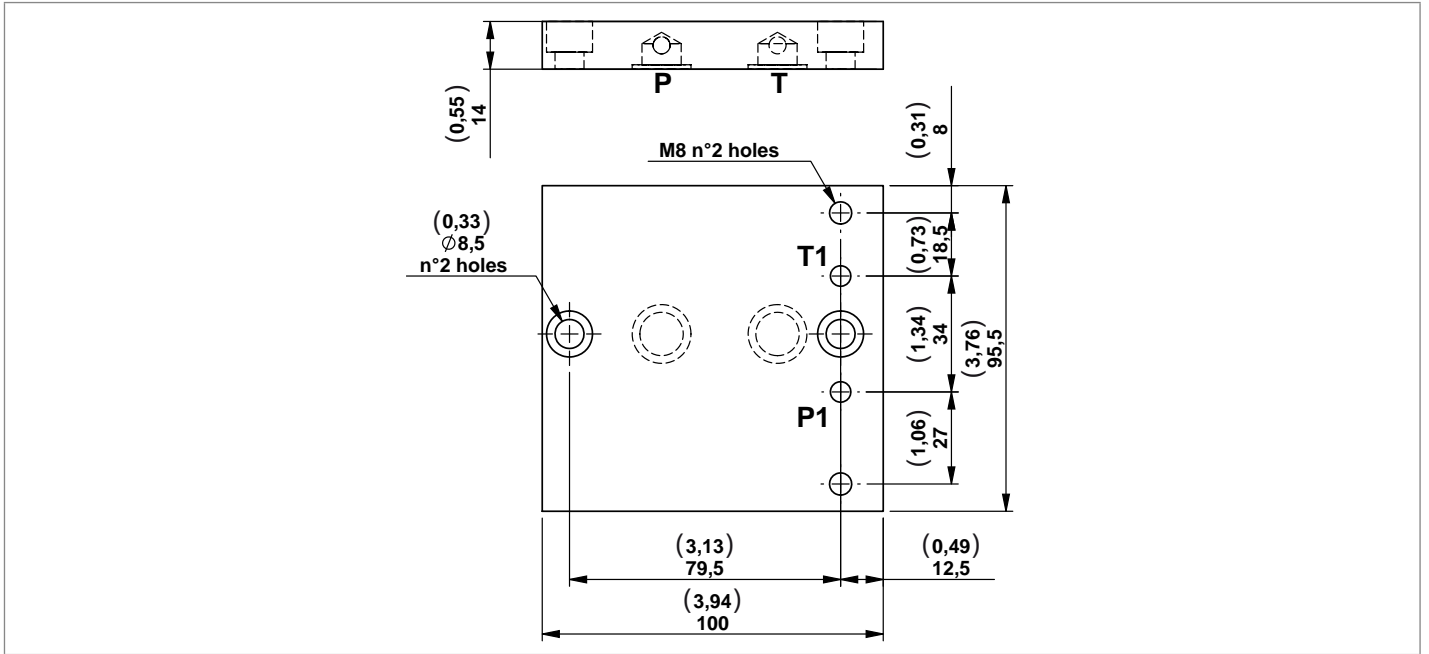

A modular block that is able to have a 90° rotation from our standard OILSISTEM configuration, but keeping the block on the same surface allowing a different position of any other modular block.  
Each block includes 2 OR 2056 gaskets.

Code	Description	Max working pressure bar (psi)	Max flow l/min (gpm)	Type	Material number
N33	90° rotation modular block	300 (4351)	20 (5,28)	G386032000	R932001110

**Application Example**

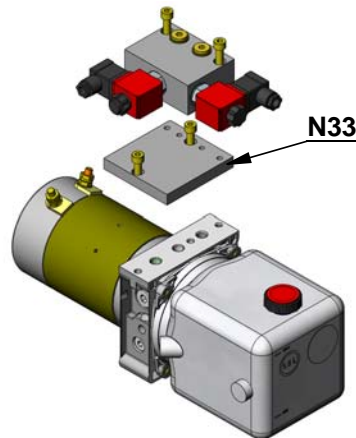

**90° modular block allowing horizontal mounting (motor side)**

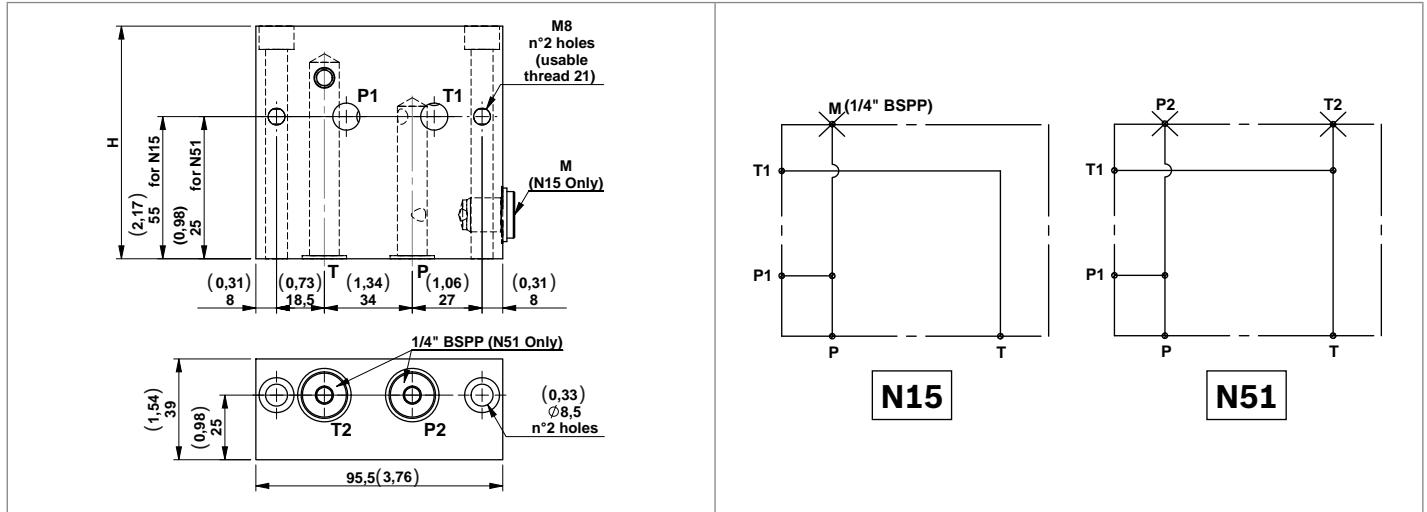

A modular block that is able to turn the standard assembling of 90°, in order to place other manifold blocks over the motor.

The “N15” block has a 1/4” BSPP port for Pressure Gauge. Each block includes 2 OR 2056 gaskets.

Code	Description	Max working pressure bar (psi)	Max flow l/min (gpm)	Type	Material number
<b>N15</b>	90° modular block allowing horizontal mounting (motor side) <b>H=90</b>	300 (4351)	35 (9,25)	G386014000	R932001087
<b>N51</b>	90° modular block allowing horizontal mounting (motor side) <b>H=60</b>	300 (4351)	35 (9,25)	G386050000	R932001146

**Motor IEC71 frame Coupling TR02**

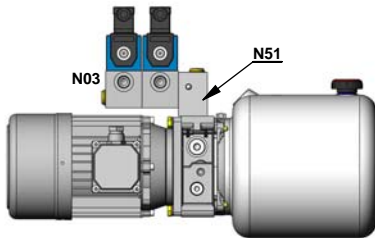

**Motor IEC80 frame Coupling TR03**

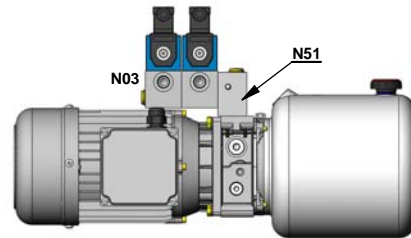

**Motor IEC90 frame Coupling TR04**

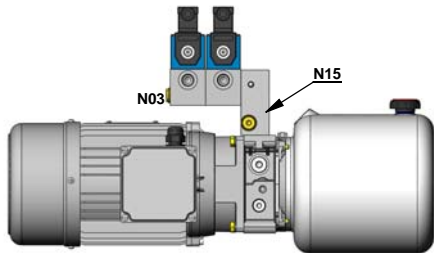

**Motor IEC100 frame Coupling TR05**

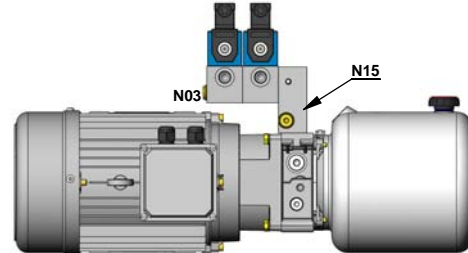

**Motor IEC112 frame Coupling TR05**

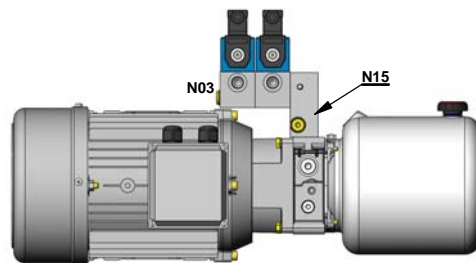

**90° modular block allowing horizontal mounting (tank side)**

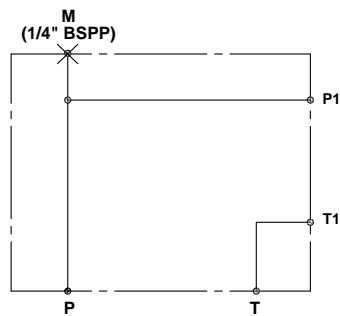
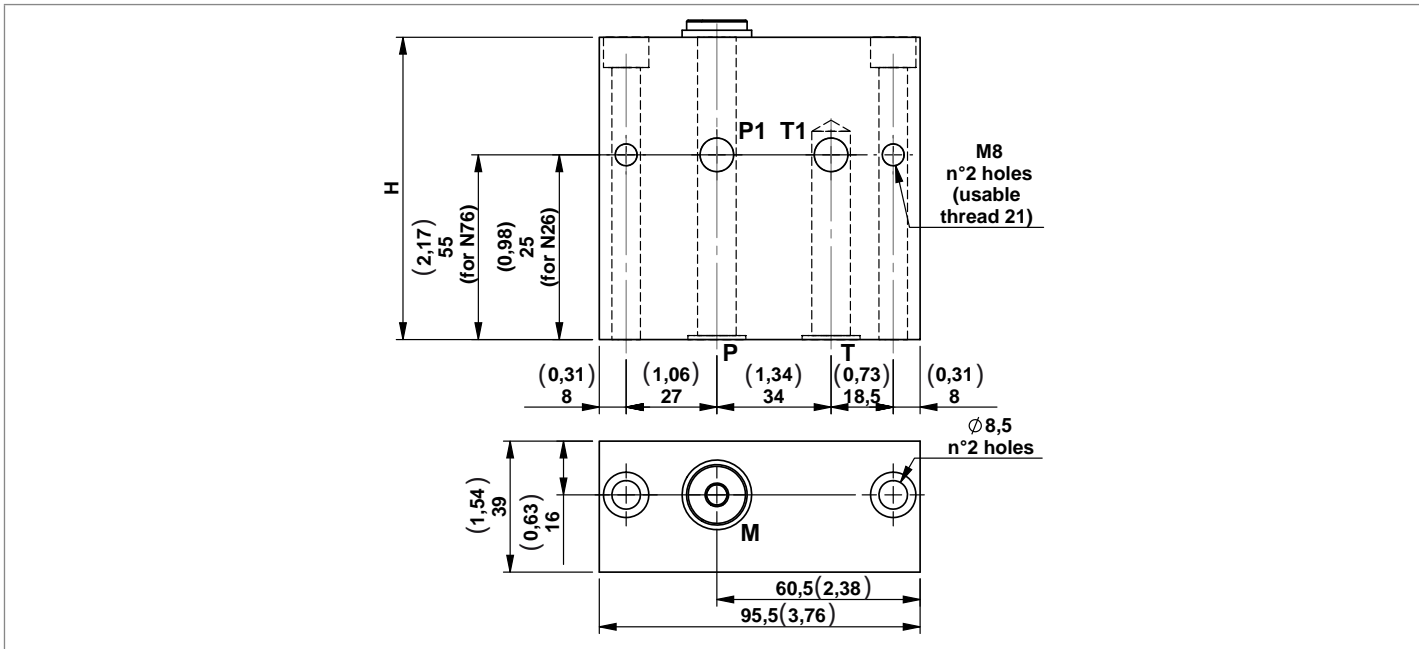

A modular block that is able to turn the standard assembling of 90°, in order to place other blocks over the tank.  
The blocks have a 1/4" BSPP port for Pressure Gauge.  
Each block includes 2 OR 2056 gaskets.

Code	Description	Max working pressure bar (psi)	Max flow l/min (gpm)	Type	Material number
<b>N76</b>	90° modular block allowing horizontal mounting (tank side) <b>H=90</b>	300 (4351)	35 (9,25)	G386075000	R932001153
<b>N26</b>	90° modular block allowing horizontal mounting (tank side) <b>H=60</b>	300 (4351)	35 (9,25)	G386025000	R932001100

**Tank H=134**

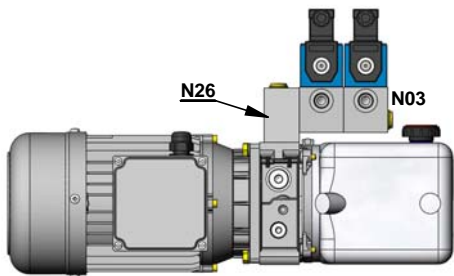

**Tank Diameter Ø190**

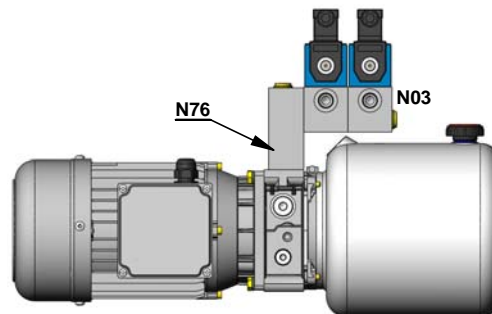

**Modular blocks with threaded ports**

Modular blocks with exit 3/8" BSPP.

Each block includes 2 OR 2056 gaskets.

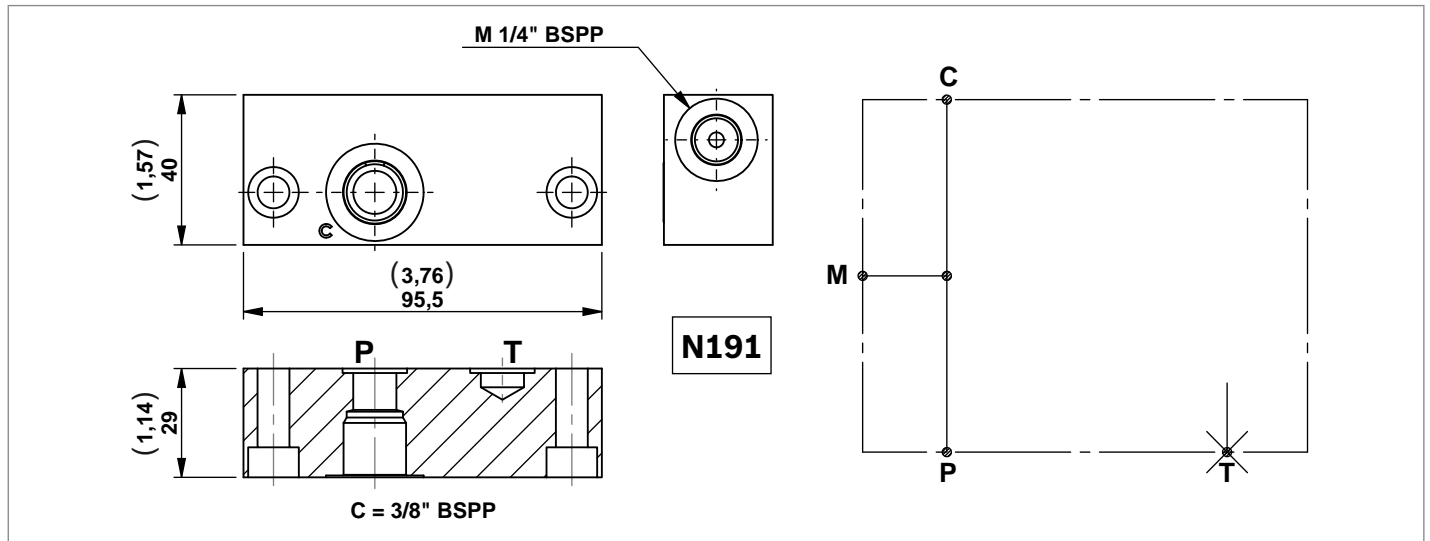
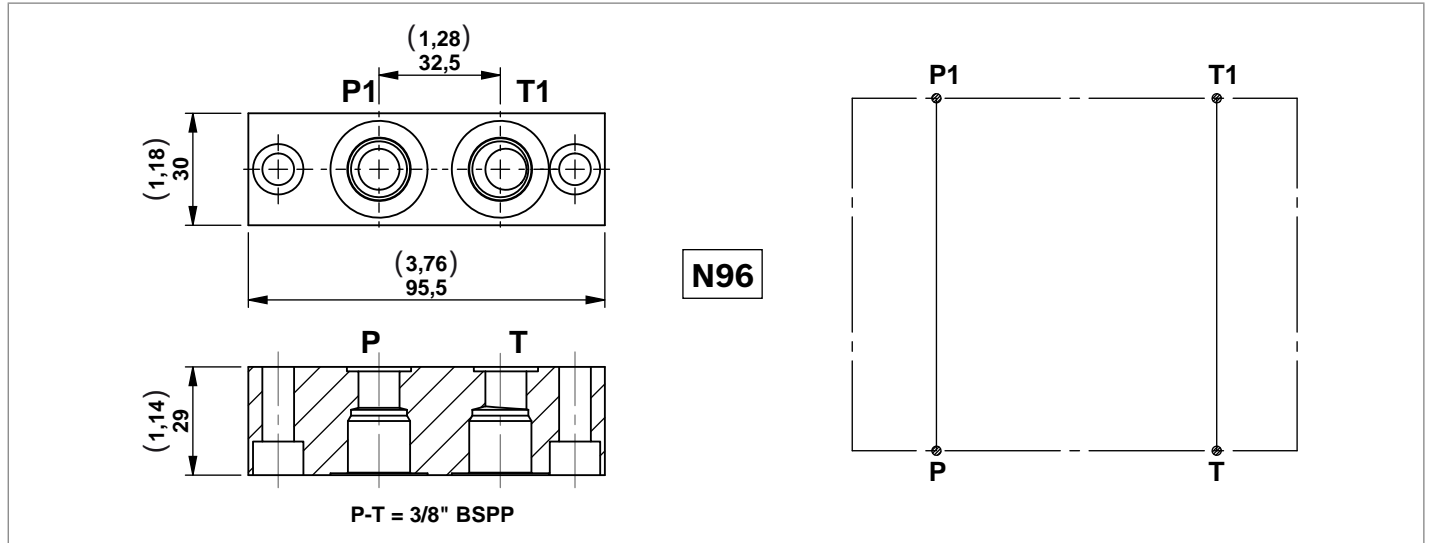

Code	Description	Max working pressure bar (psi)	Max flow l/min (gpm)	Type	Material number
<b>N96</b>	Modular block with threaded ports	300 (4351)	35 (9,25)	G386095000	R932001173
<b>N191</b>	Modular block with threaded ports	300 (4351)	35 (9,25)	G386191000	R932001284

**Modular spacer block with extra “P1” port**

A modular block with an extra port.  
Each block includes 2 OR 2056 gaskets.

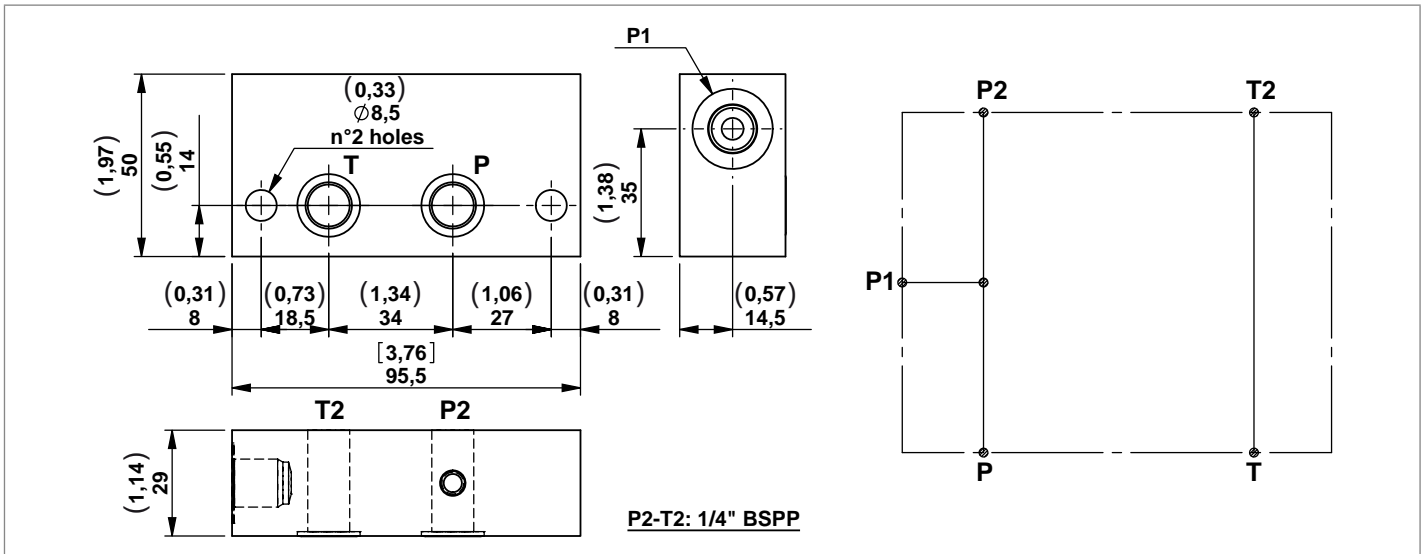

Code	Description	Max working pressure bar (psi)	Max flow l/min (gpm)	Type	Material number
<b>N46-14</b>	Modular spacer block with extra "P1" port 1/4" BSPP	300 (4351)	20 (5,28)	G386045000	R932001142
<b>N46-38</b>	Modular spacer block with extra "P1" port 3/8" BSPP	300 (4351)	20 (5,28)	1386000053	R932009506

**Modular spacer block with two 1/8" BSPP and two 1/4" BSPP ports**

A modular block with 4 extra ports.  
Each block includes 2 OR 2056 gaskets.

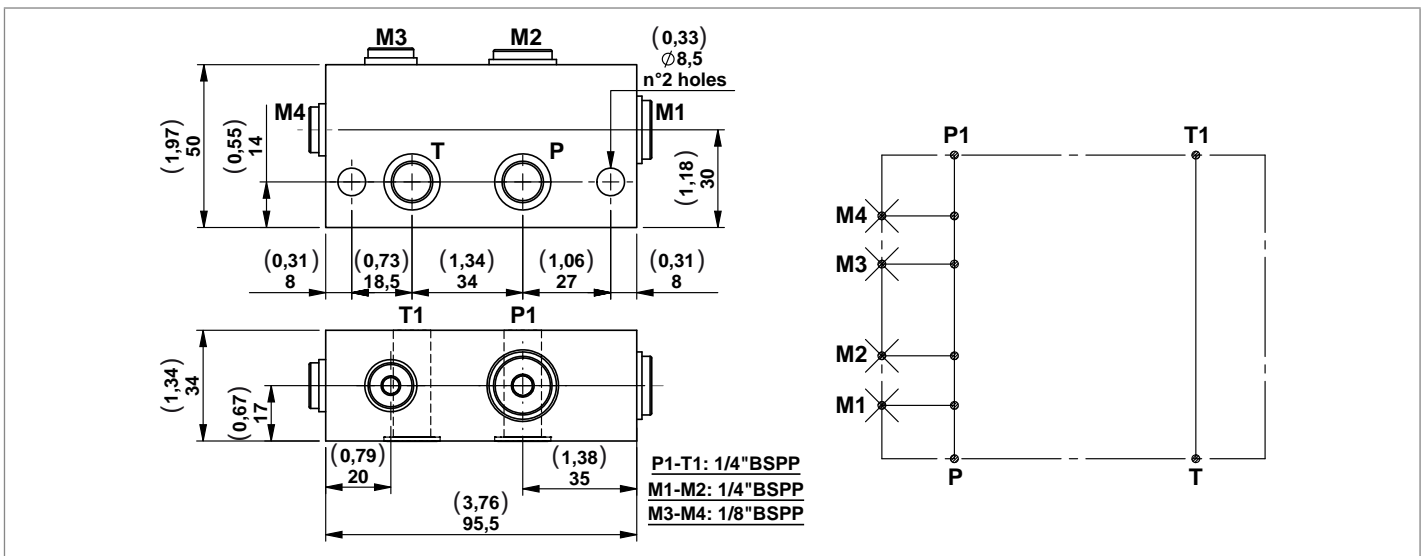

Code	Description	Max working pressure bar (psi)	Max flow l/min (gpm)	Type	Material number
<b>N128</b>	Modular spacer block with two 1/8" BSPP ports and two 1/4" BSPP ports	300 (4351)	35 (9,25)	G386128000	R932001241

**Modular block with filter on pressure line**

A modular block with a filter on the pressure line. This is recommended for applications where valve may be subjected to contamination. Each block includes 2 OR 2056 gaskets.

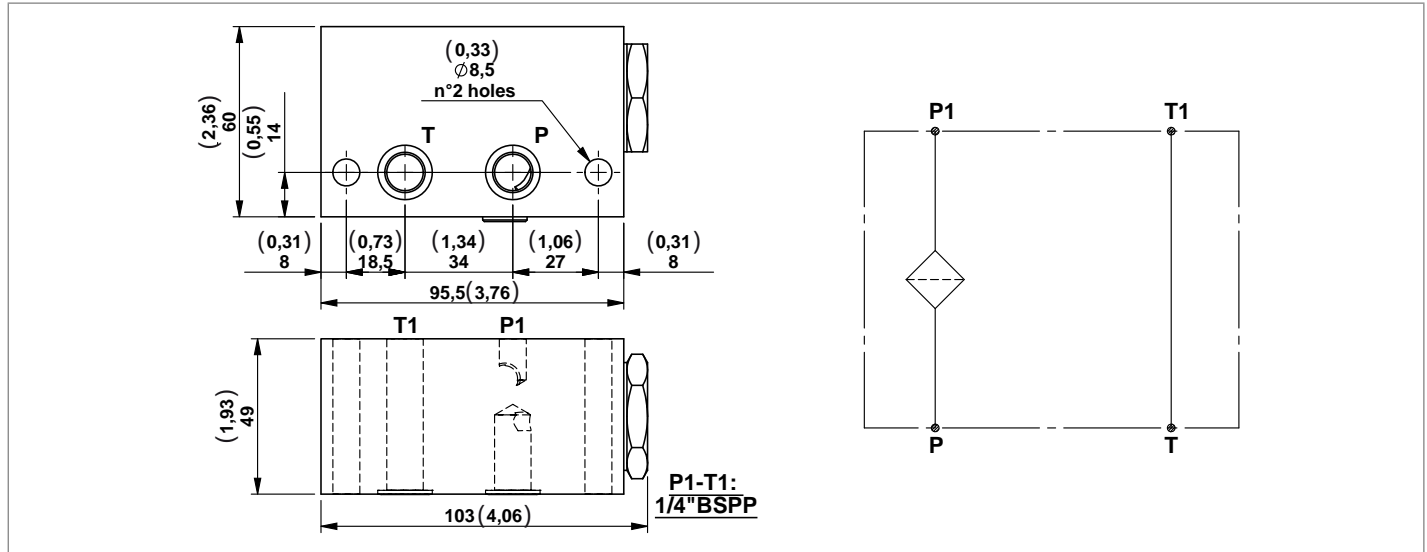

Code	Description	Max working pressure bar (psi)	Max flow l/min (gpm)	Type	Material number
N39-25	Modular block with filter (25 micron) on pressure line	230 (3336)	10 (2,64)	G386038010	R932001123
N39-60	Modular block with filter (60 micron) on pressure line	230 (3336)	10 (2,64)	G386038020	R932001124

**Modular block with filter on the return line**

A modular block with filter on return line. This is recommended for applications where valves may be subjected to contamination. Each block includes 2 OR 2056 gaskets. By-pass valve set at a pressure of 1 bar.

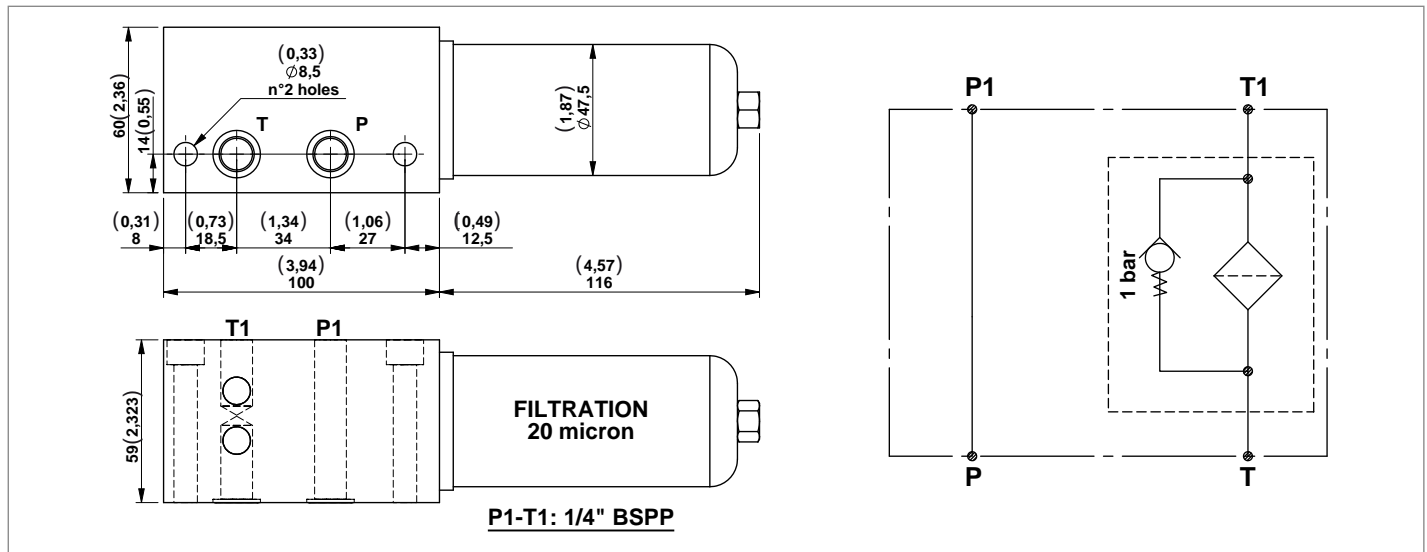

Code	Description	Max working pressure bar (psi)	Max flow l/min (gpm)	Type	Material number
N116	Modular block with filter on the return line (20 micron)	6 (87)	20 (5,28)	G386116010	R932001214

**Modular block for CETOP 3 (2143) configuration valves**

Modular blocks for CETOP 3 (2143) electrovalves for parallel or series circuits.

Each block includes 2 OR 2056 gaskets.

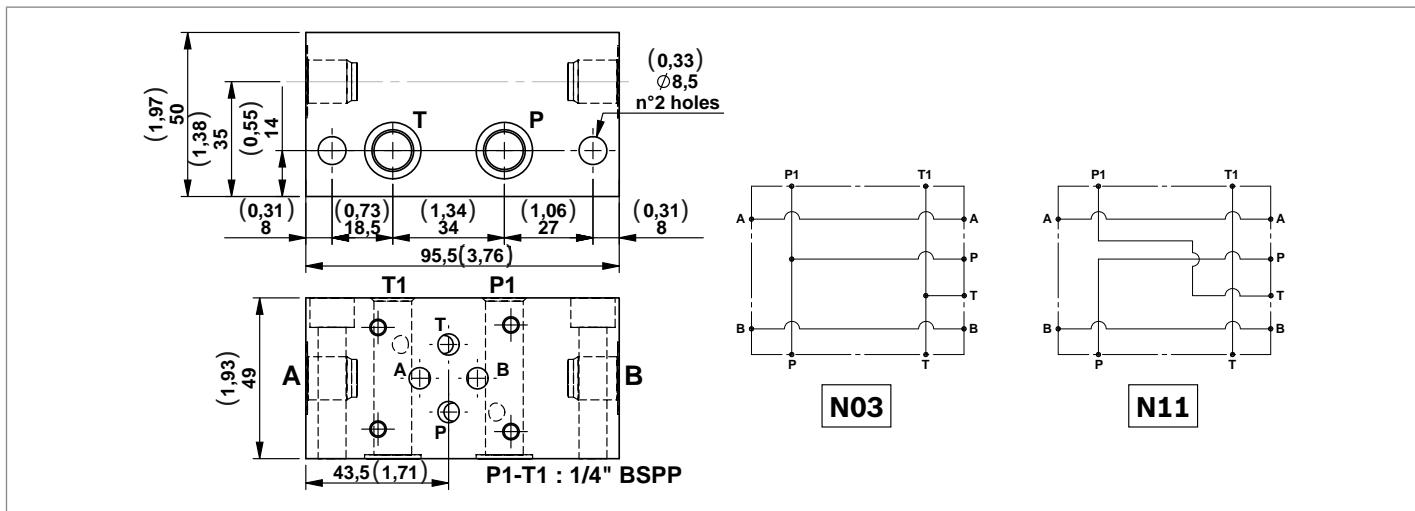

Code	Description	Max working pressure bar (psi)	Max flow l/min (gpm)	Type	Material number
<b>N03-14</b>	Modular block for CETOP3 (2143) configuration valves with A-B <b>1/4"</b> BSPP ( <b>parallel circuit</b> )	300 (4351)	40 (10,57)	G386002010	R932001010
<b>N03-38</b>	Modular block for CETOP3 (2143) configuration valves with A-B <b>3/8"</b> BSPP ( <b>parallel circuit</b> )	300 (4351)	40 (10,57)	G386002020	R932001011
<b>N11-14</b>	Modular block for CETOP3 (2143) configuration valves with A-B <b>1/4"</b> BSPP ( <b>series circuit</b> )	300 (4351)	40 (10,57)	G386009010	R932001054
<b>N11-38</b>	Modular block for CETOP3 (2143) configuration valves with A-B <b>3/8"</b> BSPP ( <b>series circuit</b> )	300 (4351)	40 (10,57)	G386009020	R932001056

**Modular block for CETOP 3 (2143) configuration valves**

A modular block that is for CETOP 3 (2143) electrovalves for a parallel circuit with ports on the oppsite side of the valve.

Each block includes 2 OR 2056 gaskets.

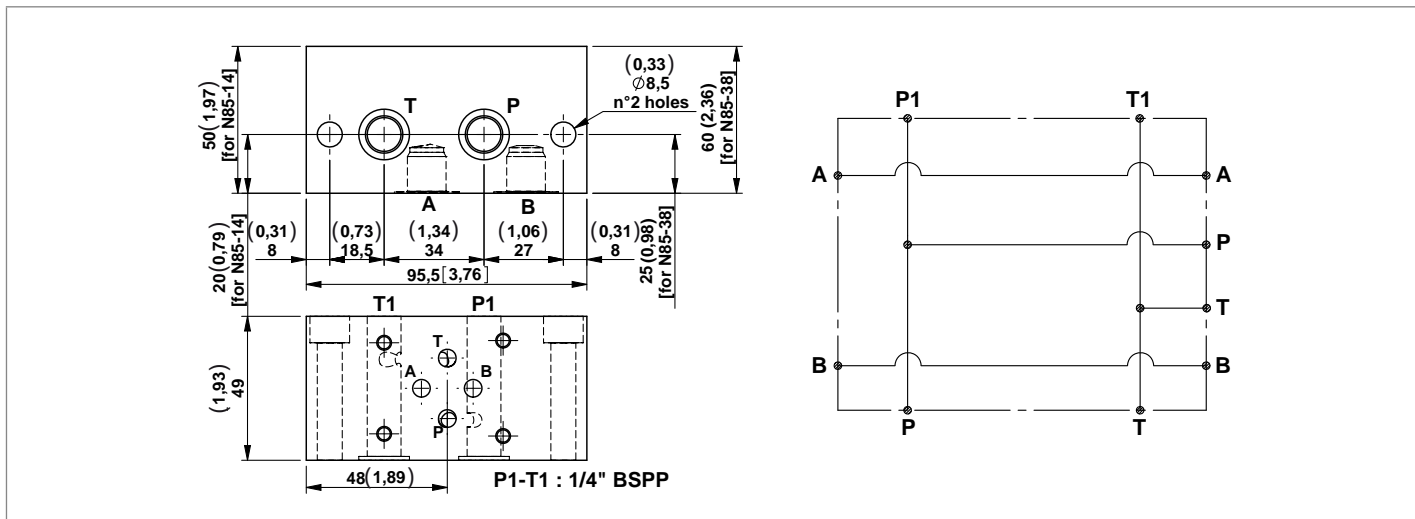

Code	Description	Max working pressure bar (psi)	Max flow l/min (gpm)	Type	Material number
<b>N85-14</b>	Modular block for CETOP3 (2143) configuration valves with A-B <b>1/4"</b> BSPP ( <b>parallel circuit</b> )	300 (4351)	40 (10,57)	G386084010	R932001158
<b>N85-38</b>	Modular block for CETOP3 (2143) configuration valves with A-B <b>3/8"</b> BSPP ( <b>parallel circuit</b> )	300 (4351)	40 (10,57)	G386084020	R932001159

**Modular block for CETOP 3 (2143) configuration valves with side ports**

A modular block that is for CETOP 3 (2143) electrovalves for parallel circuit with side device ports on one face. Each block includes 2 OR 2056 gaskets.

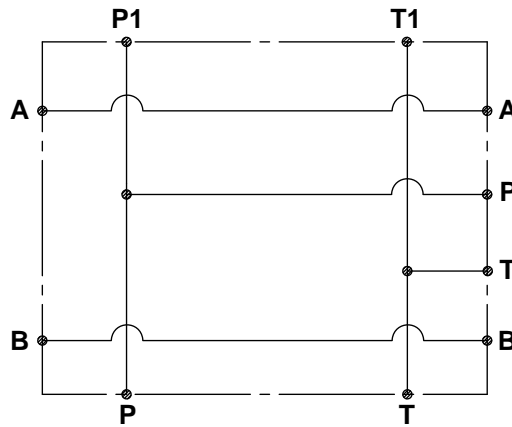
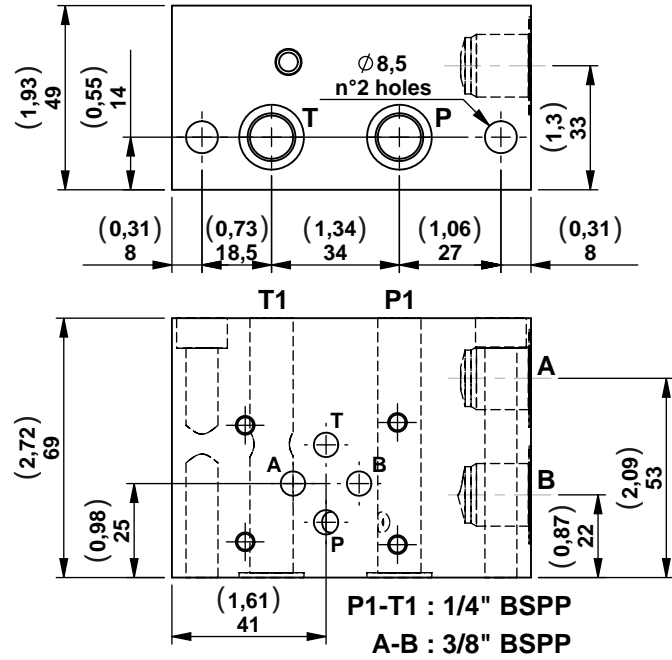

Code	Description	Max working pressure bar (psi)	Max flow l/min (gpm)	Type	Material number
N142	Modular block for CETOP 3 (2143) configuration valves with side ports	300 (4351)	40 (10,57)	G386142000	R932001252



**Modular block with poppet type P.O. check valves for CETOP 3 (2143) configuration valves (parallel circuit)**

A selection of modular block with P.O. check valves for block CETOP 3 (2143) electrovalves.

Each block includes 2 OR 2056 gaskets.

Possibility to have an OR gasket on the piloting piston for application with low flow.

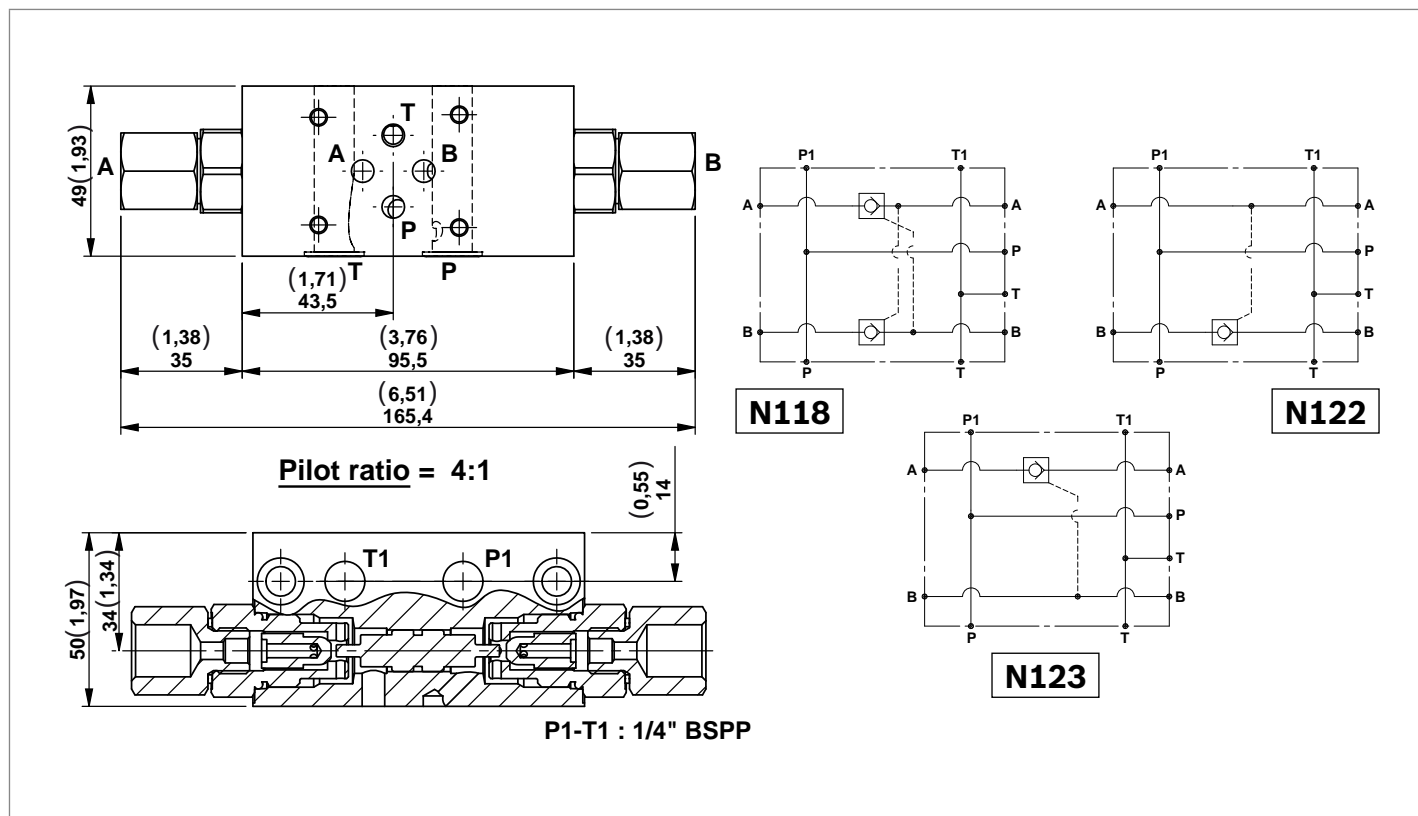

Code	Description	Max working pressure bar (psi)	Max flow l/min (gpm)	Type	Material number
<b>N118-38</b>	Modular block with poppet type P.O. check valves on A-B for CETOP 3 (2143) configuration valves <b>(without O-ring on pilot piston and A-B 3/8" BSPP)</b>	300 (4351)	20 (5,28)	G386118A02	R932001217
<b>N118G-38</b>	Modular block with poppet type P.O. check valves on A-B for CETOP 3 (2143) configuration valves <b>(with O-ring on pilot piston and A-B 3/8" BSPP)</b>	300 (4351)	20 (5,28)	G386118B02	R932001222
<b>N118-14</b>	Modular block with poppet type P.O. check valves on A-B for CETOP 3 (2143) configuration valves <b>(without O-ring on pilot piston and A-B 1/4" BSPP)</b>	300 (4351)	20 (5,28)	G386118A03	R932001218
<b>N118G-14</b>	Modular block with poppet type P.O. check valves on A-B for CETOP 3 (2143) configuration valves <b>(with O-ring on pilot piston and A-B 1/4" BSPP)</b>	300 (4351)	20 (5,28)	G386118B03	R932001223
<b>N122-38</b>	Modular block with poppet type P.O. check valve on B for CETOP 3 (2143) configuration valves <b>(without O-ring on pilot piston and A-B 3/8" BSPP)</b>	300 (4351)	20 (5,28)	G386122A02	R932001233
<b>N122-14</b>	Modular block with poppet type P.O. check valve on B for CETOP 3 (2143) configuration valves <b>(without O-ring on pilot piston and A-B 1/4" BSPP)</b>	300 (4351)	20 (5,28)	G386122A01	R932001232
<b>N123-38</b>	Modular block with poppet type P.O. check valves on A for CETOP 3 (2143) configuration valves <b>(without O-ring on pilot piston and A-B 3/8" BSPP)</b>	300 (4351)	20 (5,28)	G386123A02	R932001237
<b>N123-14</b>	Modular block with poppet type P.O. check valves on A for CETOP 3 (2143) configuration valves <b>(without O-ring on pilot piston and A-B 1/4" BSPP)</b>	300 (4351)	20 (5,28)	G386123A01	R932001236

**Sandwich blocks with poppet type "VM25" relief valves for CETOP 3 (2143) configuration valves**

Each block includes 4 OR 108 gaskets.

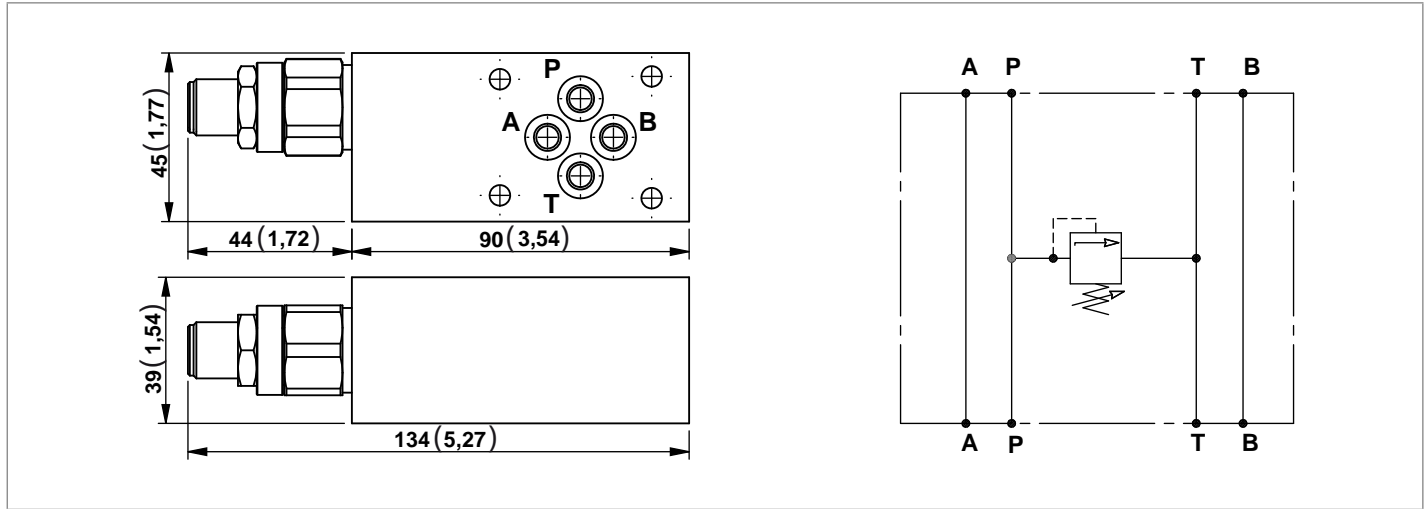

Code	Description	Max working pressure bar (psi)	Max flow l/min (gpm)	Type	Material number
<b>N99-10</b>	Sandwich block with poppet type "VM25" relief valve P in T <b>(10-100 bar)</b> for CETOP3 (2143) configuration valves	300 (4351)	25 (6,60)	G386098A81	R932001174
<b>N99-20</b>	Sandwich block with poppet type "VM25" relief valve P in T <b>(40-200 bar)</b> for CETOP3 (2143) configuration valves	300 (4351)	25 (6,60)	G386098A82	R932001175
<b>N99-35</b>	Sandwich block with poppet type "VM25" relief valve P in T <b>(70-350 bar)</b> for CETOP3 (2143) configuration valves	300 (4351)	25 (6,60)	G386098A83	R932001176

**Sandwich blocks with poppet type "VM25" relief valves for CETOP 3 (2143) configuration valves**

Each block includes 4 OR 108 gaskets.

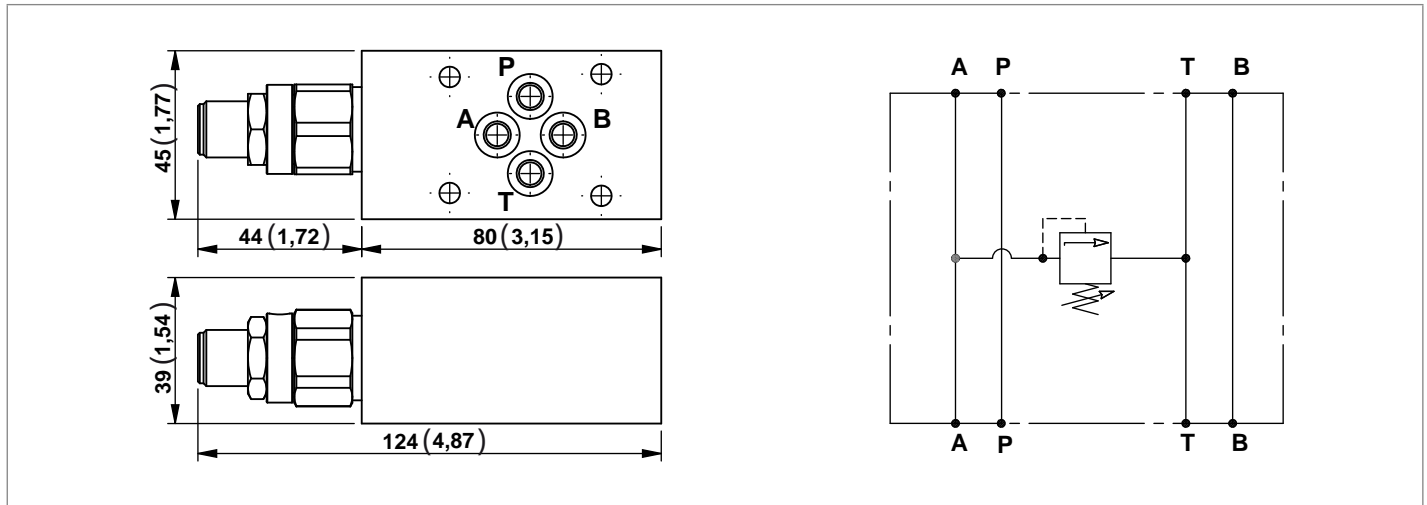

Code	Description	Max working pressure bar (psi)	Max flow l/min (gpm)	Type	Material number
<b>N100-05</b>	Sandwich block with poppet type "VM25" relief valve A in T <b>(5-50 bar)</b> for CETOP3 (2143) configuration valves	300 (4351)	25 (6,60)	G386099A84	R932001183
<b>N100-10</b>	Sandwich block with poppet type "VM25" relief valve A in T <b>(10-100 bar)</b> for CETOP3 (2143) configuration valves	300 (4351)	25 (6,60)	G386099A81	R932001180
<b>N100-20</b>	Sandwich block with poppet type "VM25" relief valve A in T <b>(40-200 bar)</b> for CETOP3 (2143) configuration valves	300 (4351)	25 (6,60)	G386099A82	R932001181
<b>N100-35</b>	Sandwich block with poppet type "VM25" relief valve A in T <b>(70-350 bar)</b> for CETOP3 (2143) configuration valves	300 (4351)	25 (6,60)	G386099A83	R932001182

**Sandwich blocks with poppet type “VM25” relief valves for CETOP 3 (2143) configuration valves**

Each block includes 4 OR 108 gaskets.

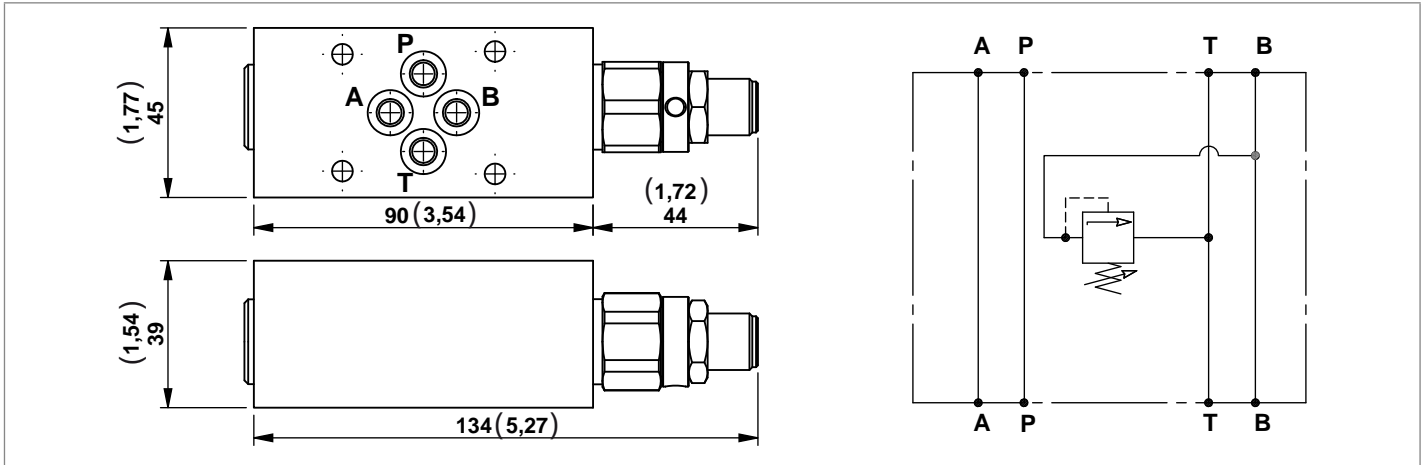

Code	Description	Max working pressure bar (psi)	Max flow l/min (gpm)	Type	Material number
<b>N101-05</b>	Sandwich block with poppet type "VM25" relief valve B in T (5-50 bar) for CETOP3 (2143) configuration valves	300 (4351)	25 (6,60)	G386101A84	R932001191
<b>N101-10</b>	Sandwich block with poppet type "VM25" relief valve B in T (10-100 bar) for CETOP3 (2143) configuration valves	300 (4351)	25 (6,60)	G386101A81	R932001188
<b>N101-20</b>	Sandwich block with poppet type "VM25" relief valve B in T (40-200 bar) for CETOP3 (2143) configuration valves	300 (4351)	25 (6,60)	G386101A82	R932001189
<b>N101-35</b>	Sandwich block with poppet type "VM25" relief valve B in T (70-350 bar) for CETOP3 (2143) configuration valves	300 (4351)	25 (6,60)	G386101A83	R932001190

**Sandwich blocks with poppet type “VM25” relief valves for CETOP 3 (2143) configuration valves**

Each block includes 4 OR 108 gaskets.

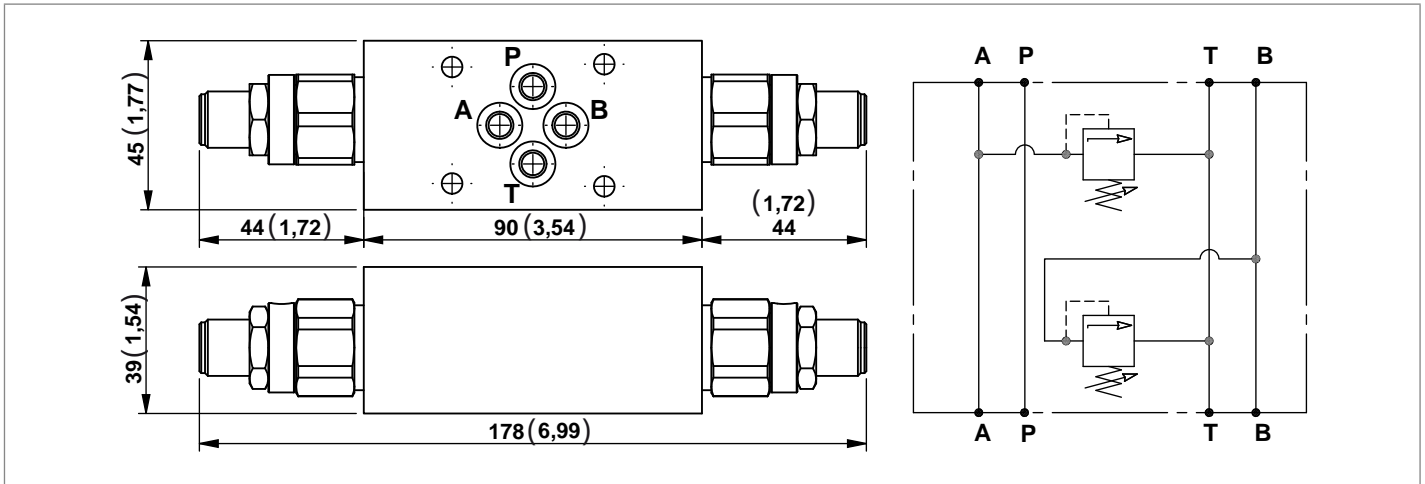

Code	Description	Max working pressure bar (psi)	Max flow l/min (gpm)	Type	Material number
<b>N102-05</b>	Sandwich block with poppet type "VM25" relief valves A-B in T (5-50 bar) for CETOP3 (2143) configuration valves	300 (4351)	25 (6,60)	G386102A84	R932001200
<b>N102-10</b>	Sandwich block with poppet type "VM25" relief valves A-B in T (10-100 bar) for CETOP3 (2143) configuration valves	300 (4351)	25 (6,60)	G386102A81	R932001196
<b>N102-20</b>	Sandwich block with poppet type "VM25" relief valves A-B in T (40-200 bar) for CETOP3 (2143) configuration valves	300 (4351)	25 (6,60)	G386102A82	R932001198
<b>N102-35</b>	Sandwich block with poppet type "VM25" relief valves A-B in T (70-350 bar) for CETOP3 (2143) configuration valves	300 (4351)	25 (6,60)	G386102A83	R932001199

**Sandwich blocks with poppet type "VM25" relief valves for CETOP 3 (2143) configuration valves**

Each block includes 4 OR 108 gaskets.

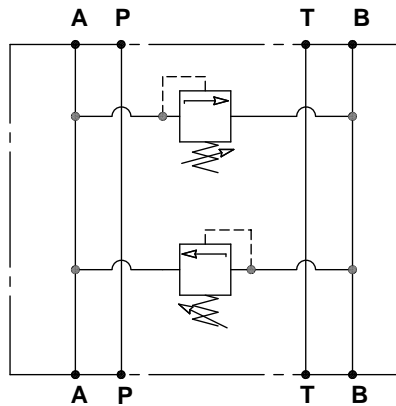
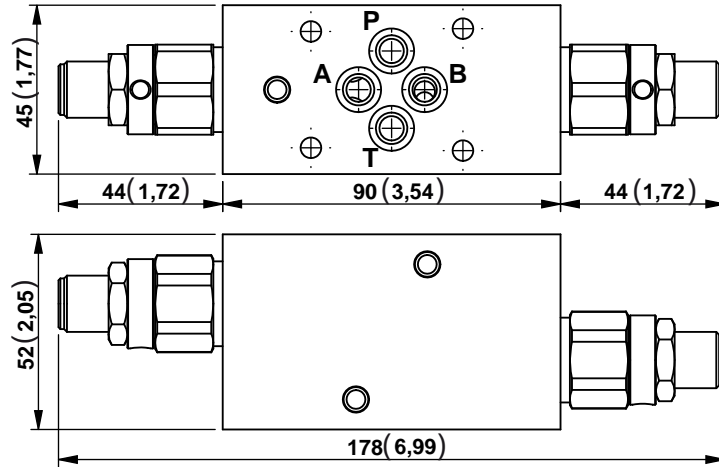

Code	Description	Max working pressure bar (psi)	Max flow l/min (gpm)	Type	Material number
<b>N103-10</b>	Sandwich block with poppet type "VM25" relief valves A in B and B in A ( <b>10-100 bar</b> ) for CETOP3 (2143) configuration valves	300 (4351)	25 (6,60)	G386103A81	R932001202
<b>N103-20</b>	Sandwich block with poppet type "VM25" relief valves A in B and B in A ( <b>40-200 bar</b> ) for CETOP3 (2143) configuration valves	300 (4351)	25 (6,60)	G386103A82	R932001203
<b>N103-35</b>	Sandwich block with poppet type "VM25" relief valves A in B and B in A ( <b>70-350 bar</b> ) for CETOP3 (2143) configuration valves	300 (4351)	25 (6,60)	G386103A83	R932001204

**Sandwich blocks with “ST-CU-06” adjustable flow control valves for CETOP 3 (2143) configuration valves**

Each block includes 4 OR 108 gaskets.

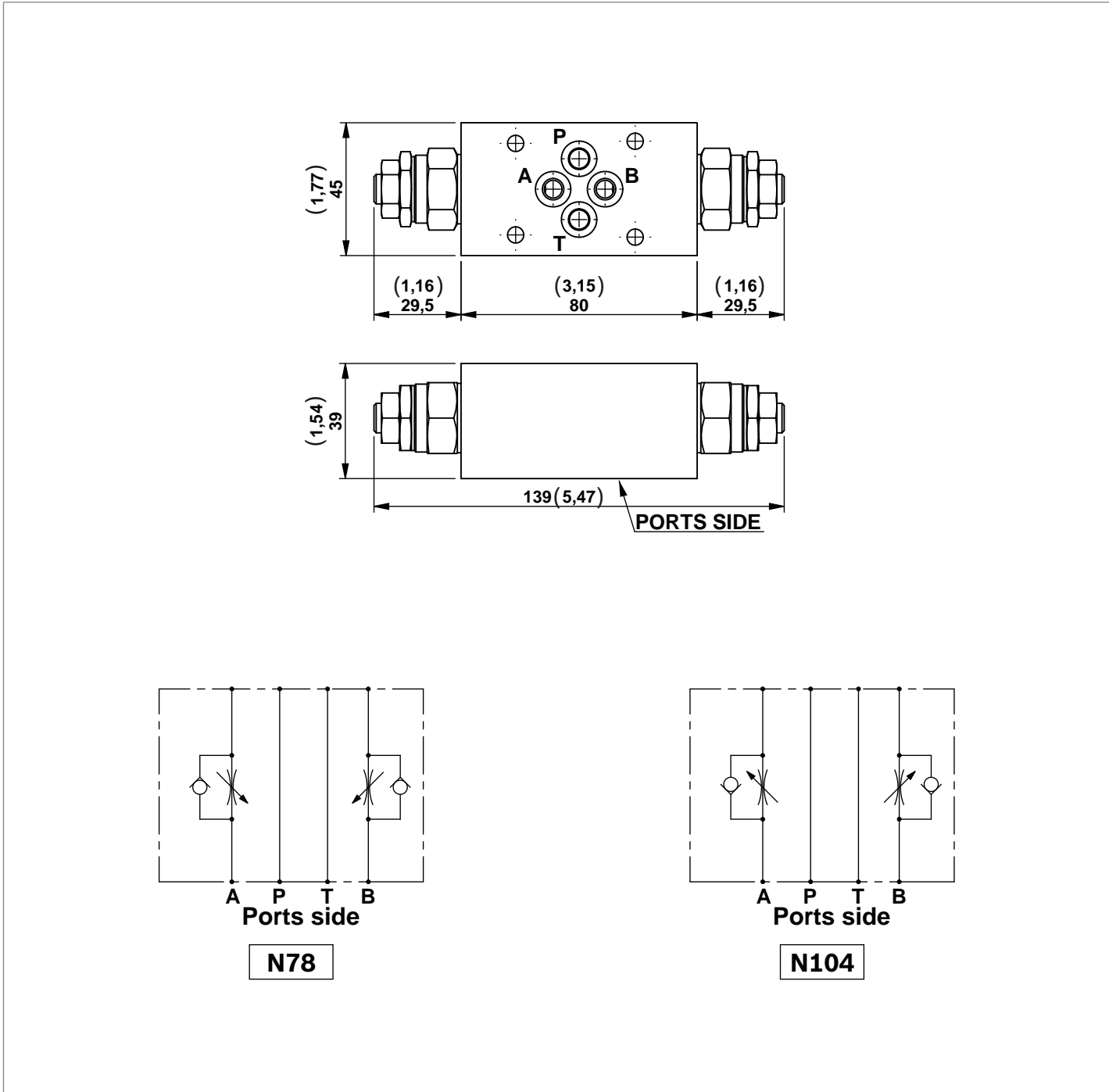

Code	Description	Max working pressure bar (psi)	Max flow l/min (gpm)	Type	Material number
<b>N78</b>	Sandwich blocks with ST-CU-06 adjustable flow control valves (that <b>working on the return to the tank</b> of the A and B line) for CETOP 3 (2143) configuration valves	300 (4351)	25 (6,60)	G386077A81	R932001156
<b>N104</b>	Sandwich blocks with ST-CU-06 adjustable flow control valves (that <b>working on the delivery</b> of the A and B line) for CETOP 3 (2143) configuration valves	300 (4351)	25 (6,60)	G386104A80	R932001205

**Sandwich blocks with “ST-CU-06” adjustable flow control valves for CETOP 3 (2143) configuration valves**

Each block includes 4 OR 108 gaskets.

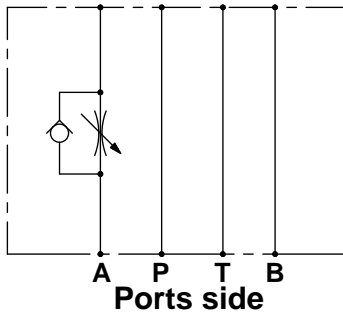
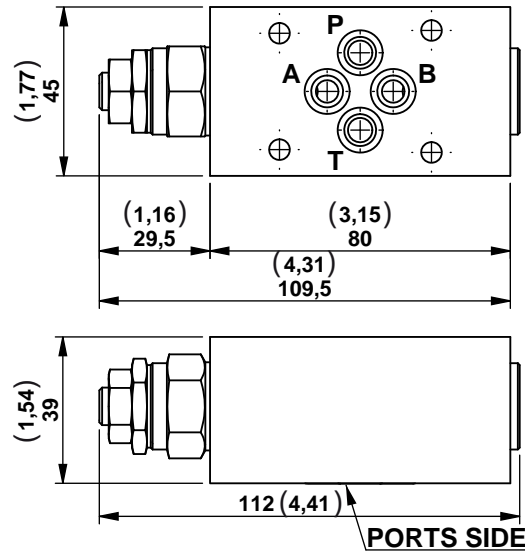

**N105**

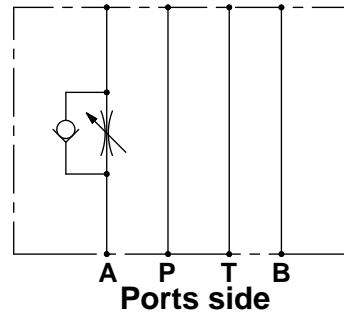

**N107**

Code	Description	Max working pressure bar (psi)	Max flow l/min (gpm)	Type	Material number
<b>N105</b>	Sandwich blocks with ST-CU-06 adjustable flow control valves (that <b>working on the return to the tank</b> of the A line) for CETOP 3 (2143) configuration valves	300 (4351)	25 (6,60)	G386105A81	R932000183
<b>N107</b>	Sandwich blocks with ST-CU-06 adjustable flow control valves (that <b>working on the delivery</b> of the A line) for CETOP 3 (2143) configuration valves	300 (4351)	25 (6,60)	G386107A80	R932001211

**Sandwich blocks with “ST-CU-06” adjustable flow control valves for CETOP 3 (2143) configuration valves**

Each block includes 4 OR 108 gaskets.

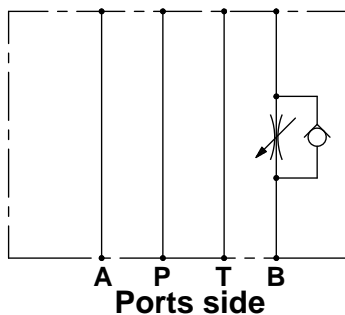
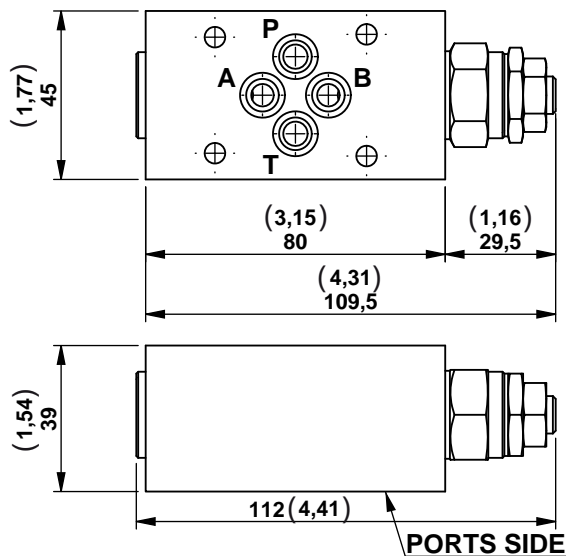

**N106**

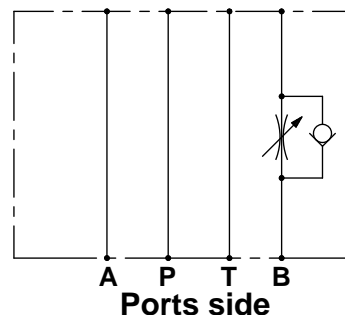

**N108**

Code	Description	Max working pressure bar (psi)	Max flow l/min (gpm)	Type	Material number
<b>N106</b>	Sandwich blocks with ST-CU-06 adjustable flow control valves (that <b>working on the return to the tank</b> of the B line) for CETOP 3 (2143) configuration valves	300 (4351)	25 (6,60)	G386106A81	R932000184
<b>N108</b>	Sandwich blocks with ST-CU-06 adjustable flow control valves (that <b>working on the delivery</b> of the B line) for CETOP 3 (2143) configuration valves	300 (4351)	25 (6,60)	G386108A80	R932001212

**Sandwich block with ports on “A” and “B” line for CETOP 3 (2143) configuration valves**

Each block includes 2 OR 2056 gaskets.

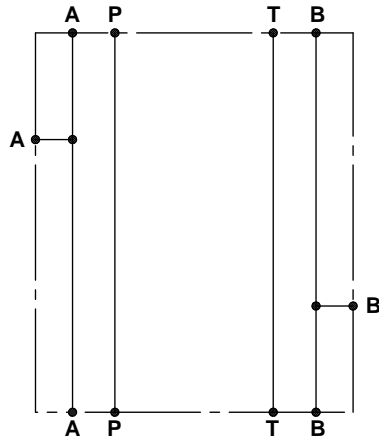
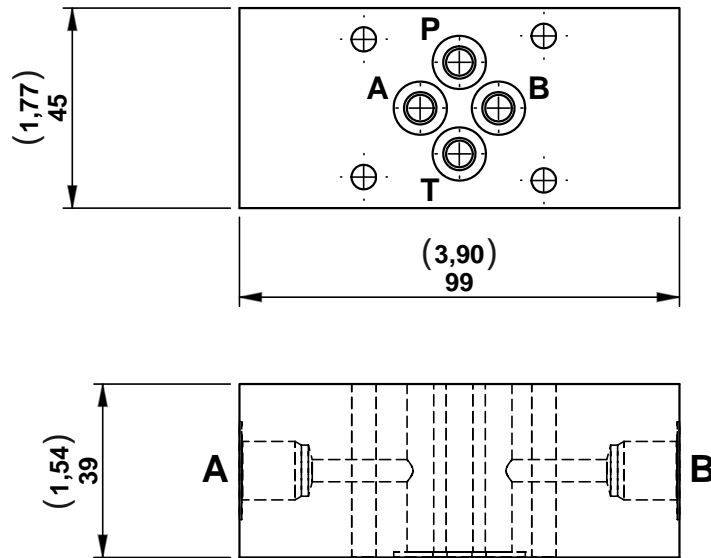

Code	Description	Max working pressure bar (psi)	Max flow l/min (gpm)	Type	Material number
<b>N19-14</b>	Sandwich block with <b>1/4"</b> BSPP ports on A and B line for CETOP3 (2143) configuration valves	300 (4351)	25 (6,60)	G386018010	R932001091



**Sandwich blocks with overcenter valves for CETOP 3 (2143) configuration valves**

Each block includes 4 OR 108 gaskets.

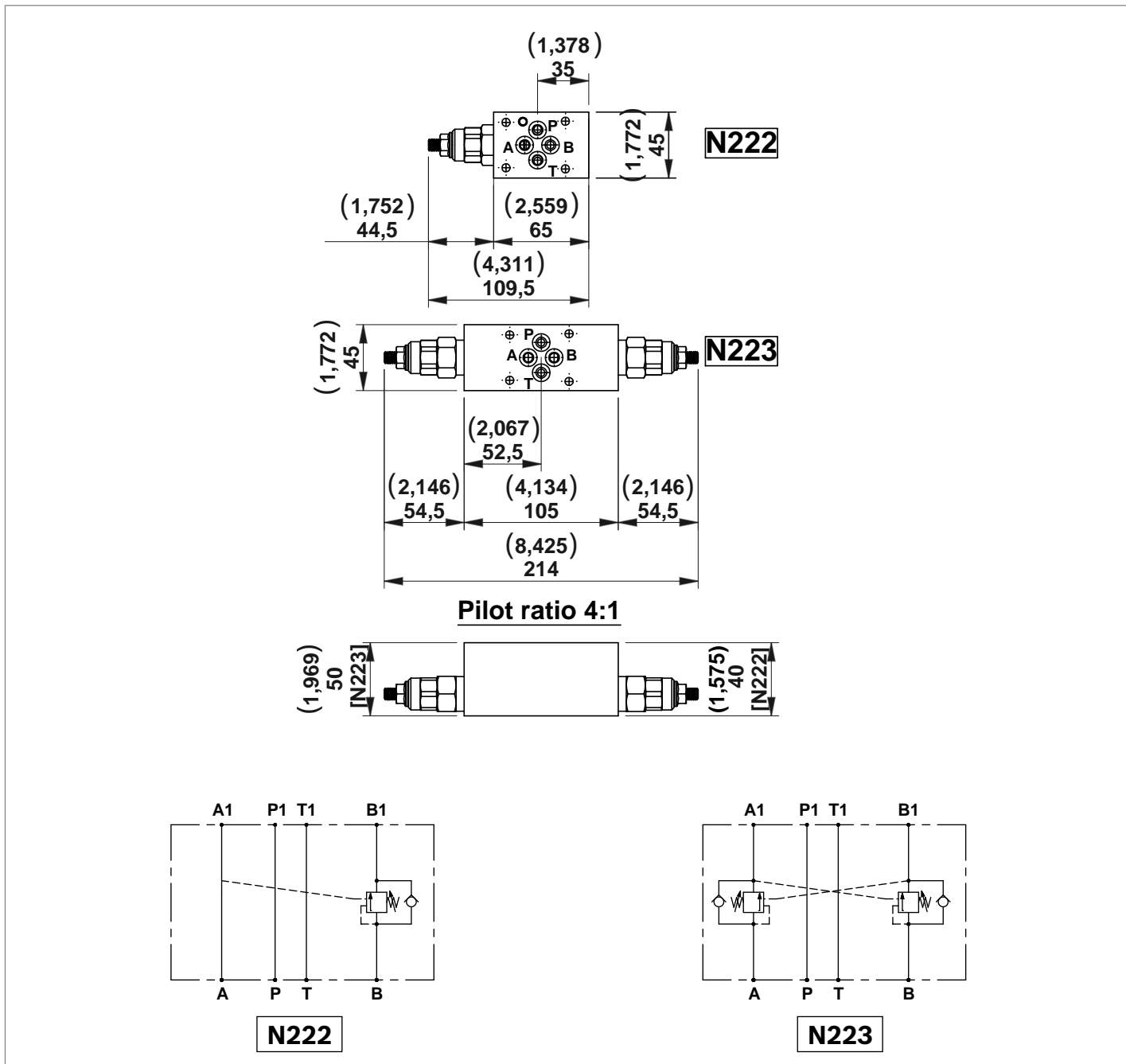

Code	Description	Max working pressure bar (psi)	Max flow l/min (gpm)	Type	Material number
<b>N222.20</b>	Sandwich block with Overcentre valve VBSN-08AA (100-210 bar) on B line for CETOP3	300 (4351)	30 (7,93)	G386222002	R932001326
<b>N222.35</b>	Sandwich block with Overcentre valve VBSN-08AA (200-350 bar) on B line for CETOP3	300 (4351)	30 (7,93)	G386222003	R932001327
<b>N223.20</b>	Sandwich block with Overcentre valves VBSN-08AA (100-210 bar) on A and B line for CETOP3	300 (4351)	30 (7,93)	G386223002	R932001329
<b>N223.35</b>	Sandwich block with Overcentre valves VBSN-08AA (200-350 bar) on A and B line for CETOP3	300 (4351)	30 (7,93)	G386223003	R932001330

**Block with pilot operated check valves on A and B line, only for manifolds KE type code M21-M25**

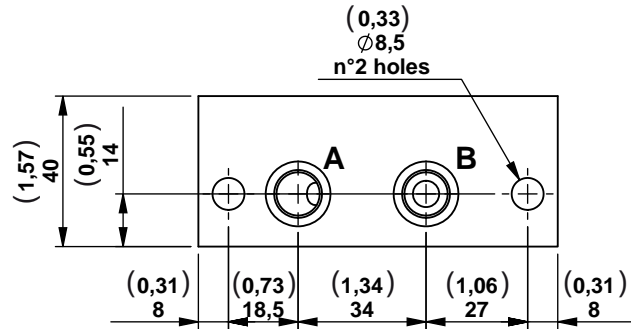

**Pilot ratio: 4:1**

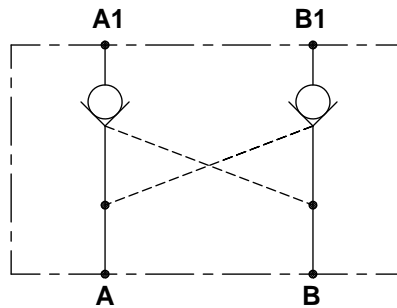
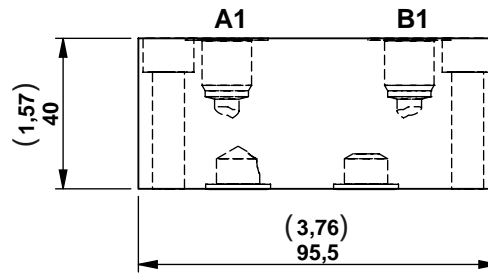

Code	Description	Max working pressure bar (psi)	Max flow l/min (gpm)	Type	Material number
<b>N221-14</b>	Block with pilot operated check valves with ports A1-B1 1/4" BSPP	210 (3046)	12 (3,17)	G386221001	R932001325
<b>N221-916</b>	Block with pilot operated check valves with ports A1-B1 SAE 9/16"	210 (3046)	12 (3,17)	G386221000	R932001324

**Modular hand pump manifold block**

A single acting hand pump usually used for emergency.  
Each block includes 5 OR 2050 gaskets.

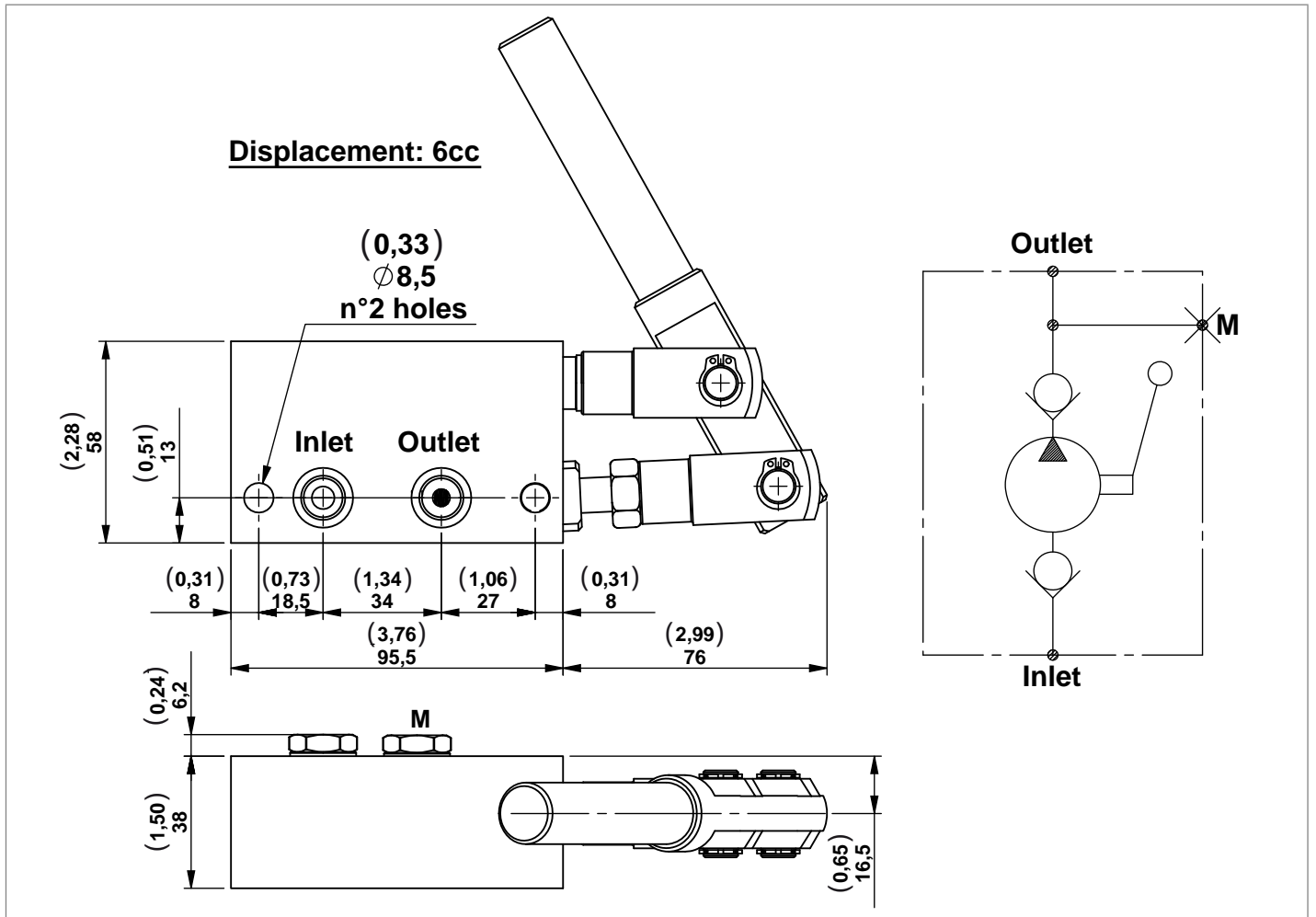

Code	Description	Max working pressure bar (psi)	Max flow l/min (gpm)	Type	Material number
N22	Modular hand pump manifold block	350 (5076)	-	G386021010	R932001093

**Lever Kit**

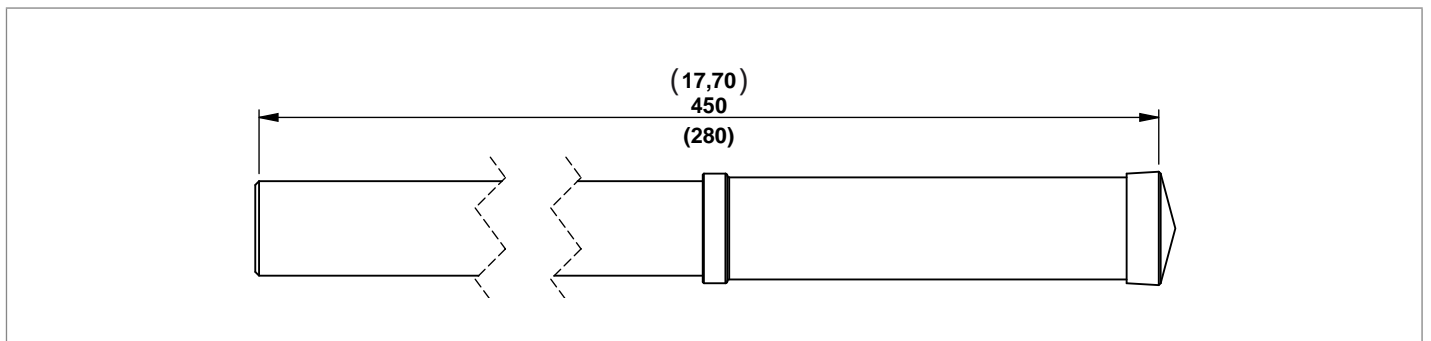

Description	Type	Material number
Lever L= 450	K250133000	R932002452
Lever L= 280	K2501S1058	R932002407

**CETOP 2143 [Ø6mm (0,24inch)] Solenoid Valves**

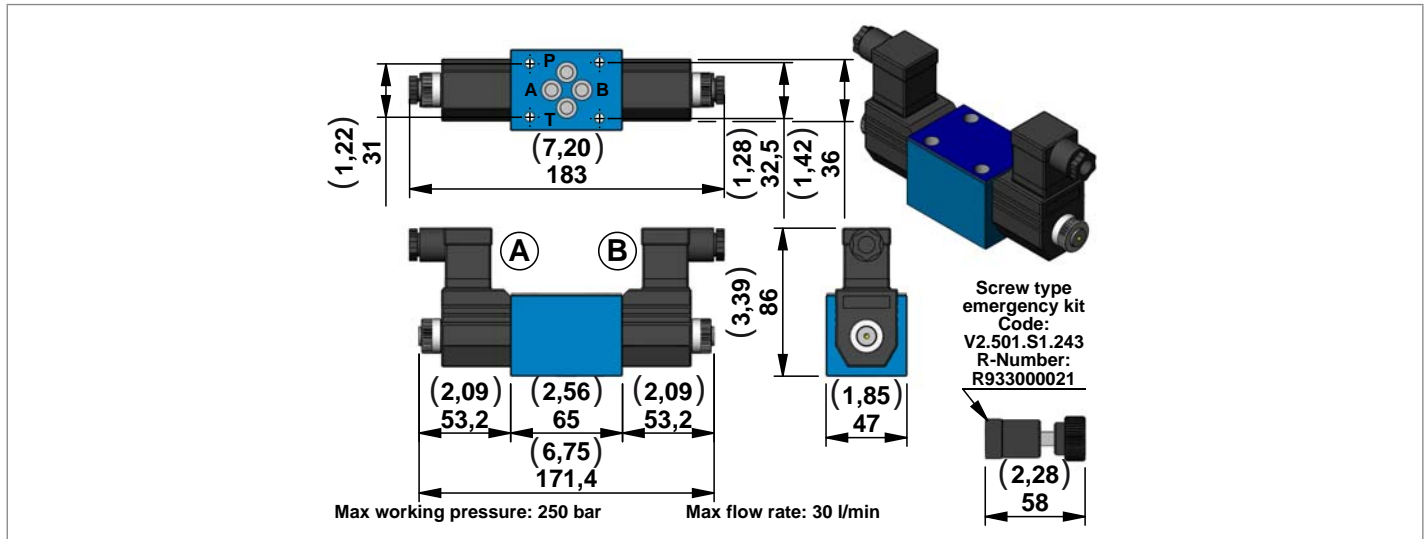

Code	Description	Max working pressure bar (psi)	Max flow l/min (gpm)	Material number	Diagram
<b>E02Z-OB</b>	CETOP3 solenoid valve 12V D.C.	250 (3626)	30 (7,92)	R933004275	
<b>E02Z-OC</b>	CETOP3 solenoid valve 24V D.C.	250 (3626)	30 (7,92)	R933004277	
<b>E02Z-OV</b>	CETOP3 solenoid valve 24V RAC	250 (3626)	30 (7,92)	R933004279	
<b>E02Z-OZ</b>	CETOP3 solenoid valve 220V RAC	250 (3626)	30 (7,92)	R933004281	
<b>E06Z-OB</b>	CETOP3 solenoid valve 12V D.C.	250 (3626)	30 (7,92)	R933004096	
<b>E06Z-OC</b>	CETOP3 solenoid valve 24V D.C.	250 (3626)	30 (7,92)	R933004098	
<b>E06Z-OD</b>	CETOP3 solenoid valve 48V D.C.	250 (3626)	30 (7,92)	R933007830	
<b>E06Z-OV</b>	CETOP3 solenoid valve 24V RAC	250 (3626)	30 (7,92)	R933004102	
<b>E06Z-OW</b>	CETOP3 solenoid valve 110V RAC	250 (3626)	30 (7,92)	R933004103	
<b>E06Z-OZ</b>	CETOP3 solenoid valve 220V RAC	250 (3626)	30 (7,92)	R933004104	
<b>E07Z-OB</b>	CETOP3 solenoid valve 12V D.C.	250 (3626)	30 (7,92)	R933004131	
<b>E07Z-OC</b>	CETOP3 solenoid valve 24V D.C.	250 (3626)	30 (7,92)	R933004133	
<b>E07Z-OD</b>	CETOP3 solenoid valve 48V D.C.	250 (3626)	30 (7,92)	R933004135	
<b>E07Z-OV</b>	CETOP3 solenoid valve 24V RAC	250 (3626)	30 (7,92)	R933004136	
<b>E07Z-OW</b>	CETOP3 solenoid valve 110V RAC	250 (3626)	30 (7,92)	R933004137	
<b>E07Z-OZ</b>	CETOP3 solenoid valve 220V RAC	250 (3626)	30 (7,92)	R933004138	
<b>E08Z-OB</b>	CETOP3 solenoid valve 12V D.C.	250 (3626)	30 (7,92)	R933004191	
<b>E08Z-OC</b>	CETOP3 solenoid valve 24V D.C.	250 (3626)	30 (7,92)	R933004193	
<b>E08Z-OD</b>	CETOP3 solenoid valve 48V D.C.	250 (3626)	30 (7,92)	R933004197	
<b>E08Z-OV</b>	CETOP3 solenoid valve 24V RAC	250 (3626)	30 (7,92)	R933004198	
<b>E08Z-OW</b>	CETOP3 solenoid valve 110V RAC	250 (3626)	30 (7,92)	R933004199	
<b>E08Z-OZ</b>	CETOP3 solenoid valve 220V RAC	250 (3626)	30 (7,92)	R933004200	
<b>E10Z-OB</b>	CETOP3 solenoid valve 12V D.C.	250 (3626)	30 (7,92)	R933004057	
<b>E10Z-OC</b>	CETOP3 solenoid valve 24V D.C.	250 (3626)	30 (7,92)	R933004061	
<b>E10Z-OD</b>	CETOP3 solenoid valve 48V D.C.	250 (3626)	30 (7,92)	R933004063	
<b>E10Z-OV</b>	CETOP3 solenoid valve 24V RAC	250 (3626)	30 (7,92)	R933004065	
<b>E10Z-OW</b>	CETOP3 solenoid valve 110V RAC	250 (3626)	30 (7,92)	R933004067	
<b>E10Z-OZ</b>	CETOP3 solenoid valve 220V RAC	250 (3626)	30 (7,92)	R933004068	

**Design**

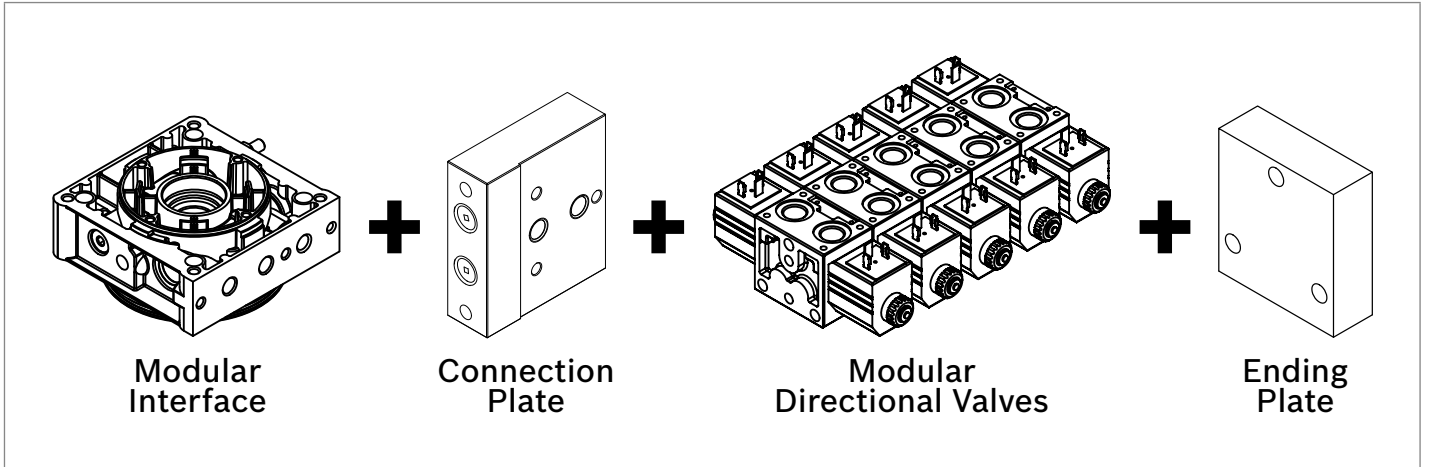

**Horizontal Example**

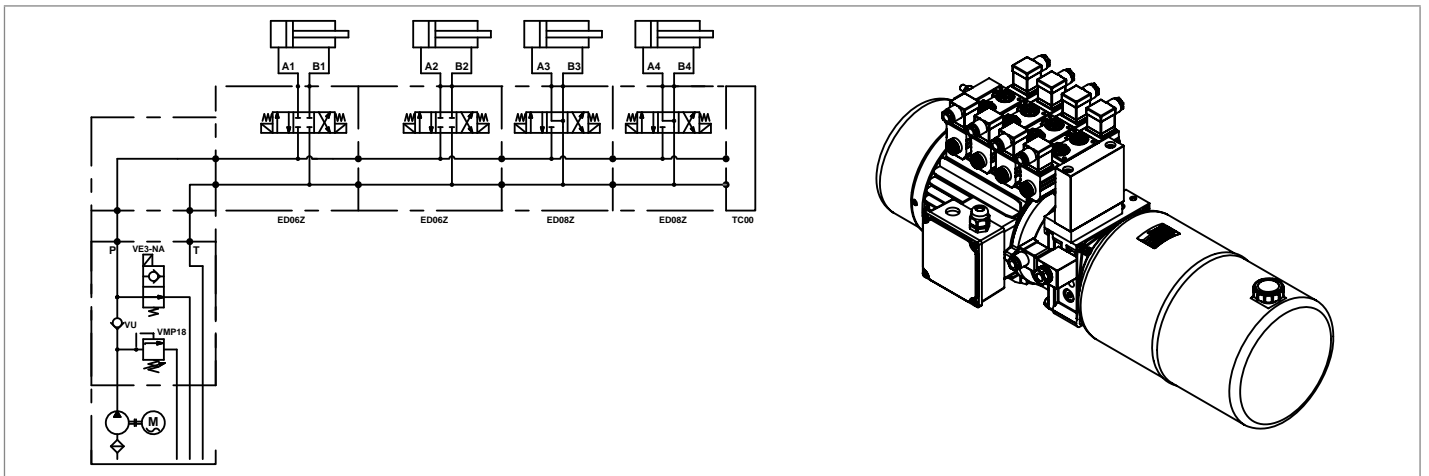

**CETOP 2143 [Ø6mm (0,24inch)] Solenoid Valves**

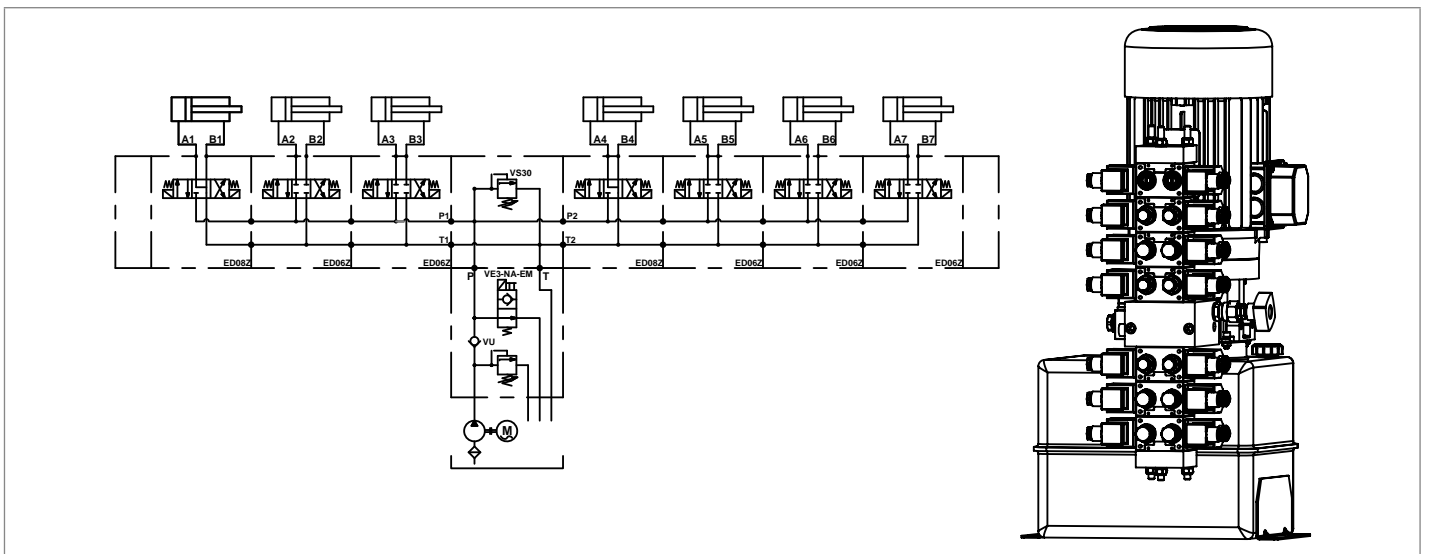

**Note**  
Please contact our Sales Department for further information.

**Modular blocks with two lowering solenoid valves, check valves, and compensated flow control throttle valves (available upon request)**

Modular blocks to operate a single acting cylinder in a parallel circuit or a double acting cylinder in regenerative.

Each block includes 2 OR 2056 gaskets.

Minimum voltage required: 90% of nominal.

Coils not included, must be ordered separately.

For the selection of coil model and voltage please refer to page 72.

For the selection of connectors please refer to page 75.

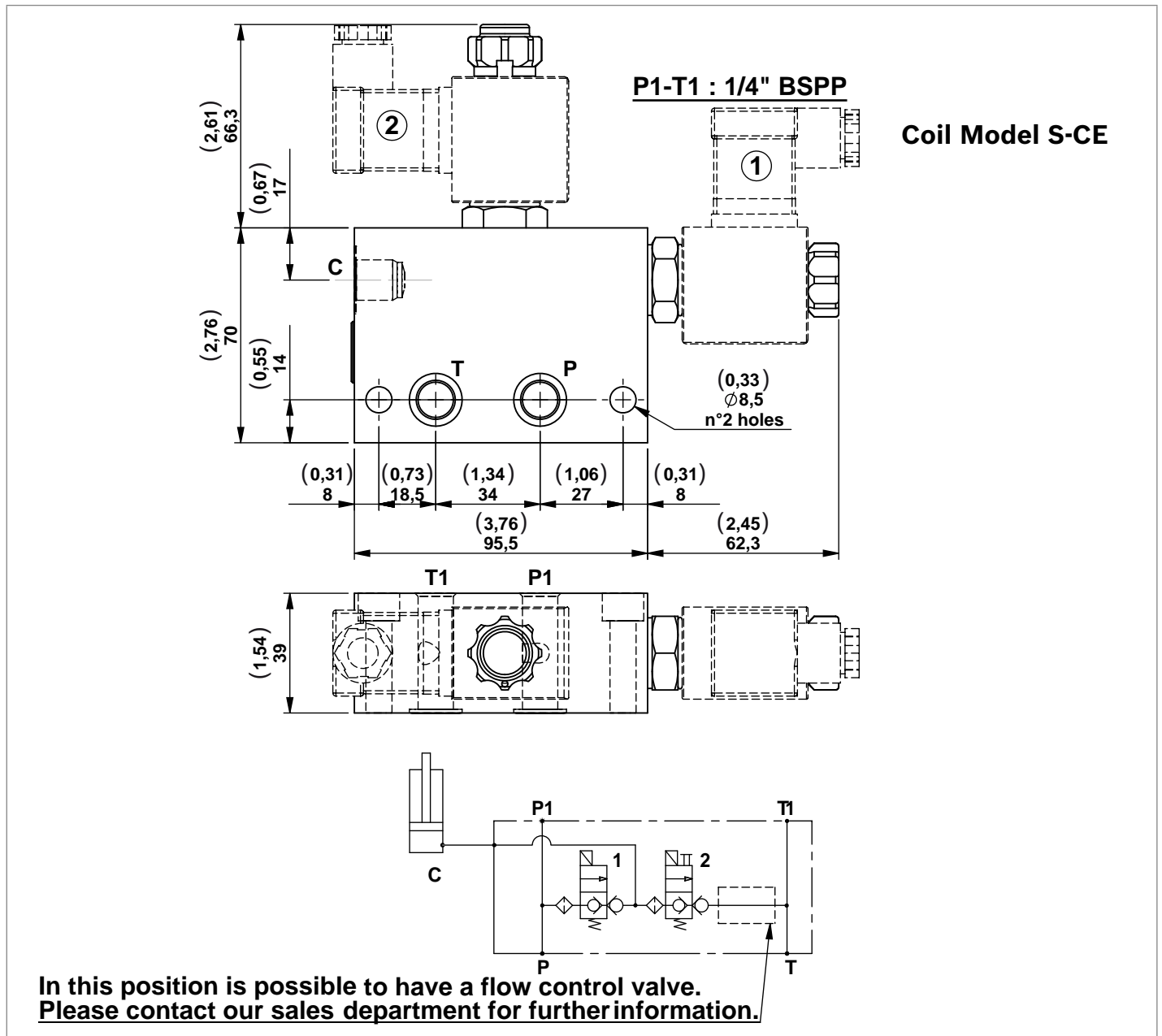

Code	Description	Max working pressure bar (psi)	Max flow l/min (gpm)	Type	Material number
V07-14	Modular block with 2 VE3-NC-VU with "C" port 1/4" BSPP	250 (3626)	25 (6,60)	G386507010DC	R932001406
V07-38	Modular block with 2 VE3-NC-VU with "C" port 3/8" BSPP	250 (3626)	25 (6,60)	G386507020DC	R932009707

**Modular blocks with four way three position solenoid valve. Spool type**

A selection of modular blocks with 4/3 spool type solenoid valve for small double acting cylinders.

Each block includes 2 OR 2056 gaskets.

Minimum voltage required: 90% of nominal.

Coils not included, must be ordered separately.

For the selection of coil model and voltage please refer to page 72.

For the selection of connectors please refer to page 75.

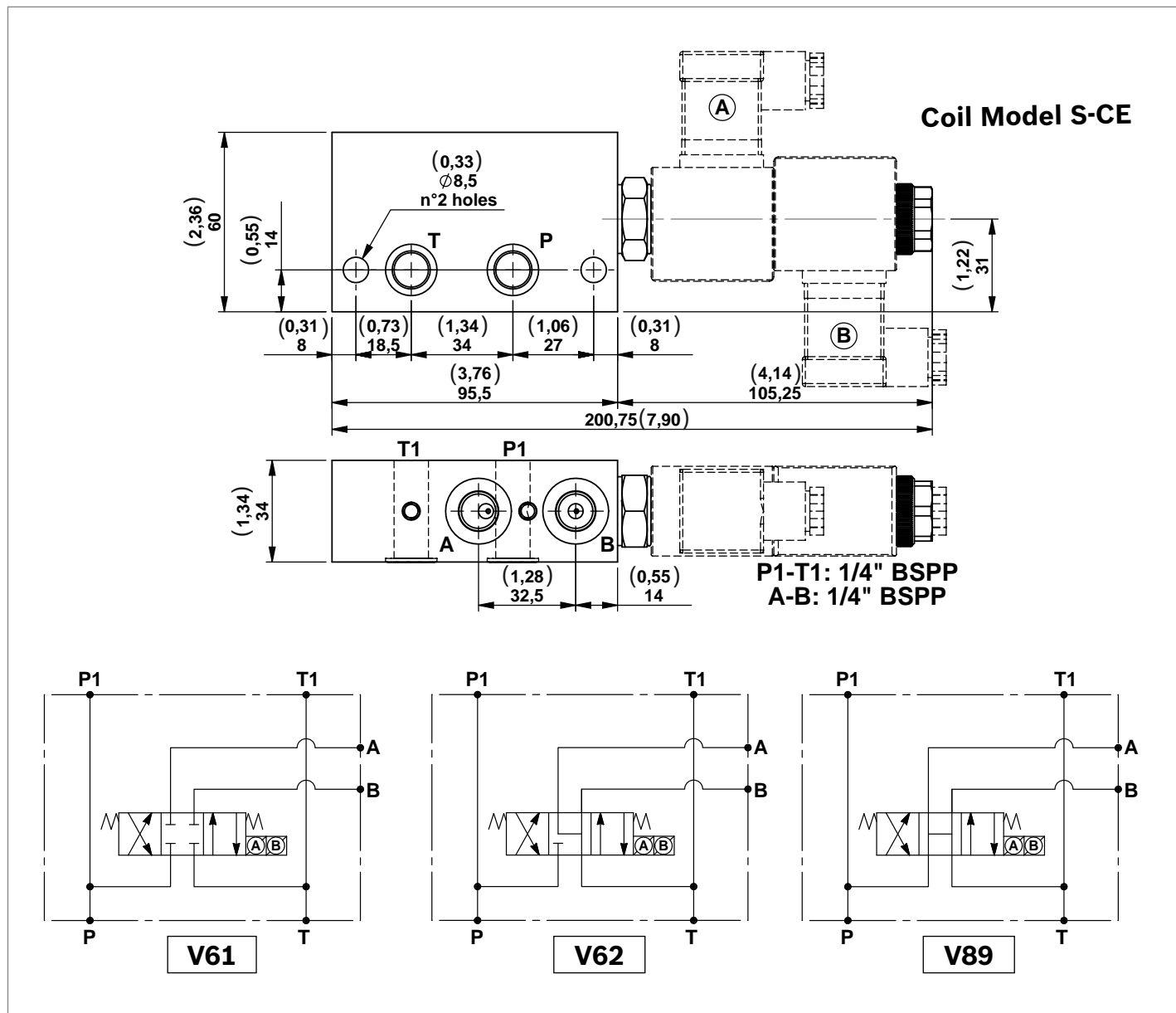

Code	Description	Max working pressure bar (psi)	Max flow l/min (gpm)	Type	Material number
<b>V61</b>	Modular block with 4 way 3 position solenoid valve (V4.3A)	210 (3046)	8 (2,11)	G386562010	R932001552
<b>V62</b>	Modular block with 4 way 3 position solenoid valve (V4.3B)	210 (3046)	8 (2,11)	G386563010	R932001556
<b>V89</b>	Modular block with 4 way 3 position solenoid valve (V4.3C)	210 (3046)	8 (2,11)	G386590010	R932001580

**Modular block with four way three position solenoid valve and P.O. check valves on “A” and “B” line**

A modular block with 4/3 spool type solenoid valve and P.O. check valves on “A” and “B” line. For small double acting cylinders. Each block includes 2 OR 2056 gaskets.

Minimum voltage required: 90% of nominal.

Coils not included, must be ordered separately.

For the selection of coil model and voltage please refer to page 72.

For the selection of connectors please refer to page 75.

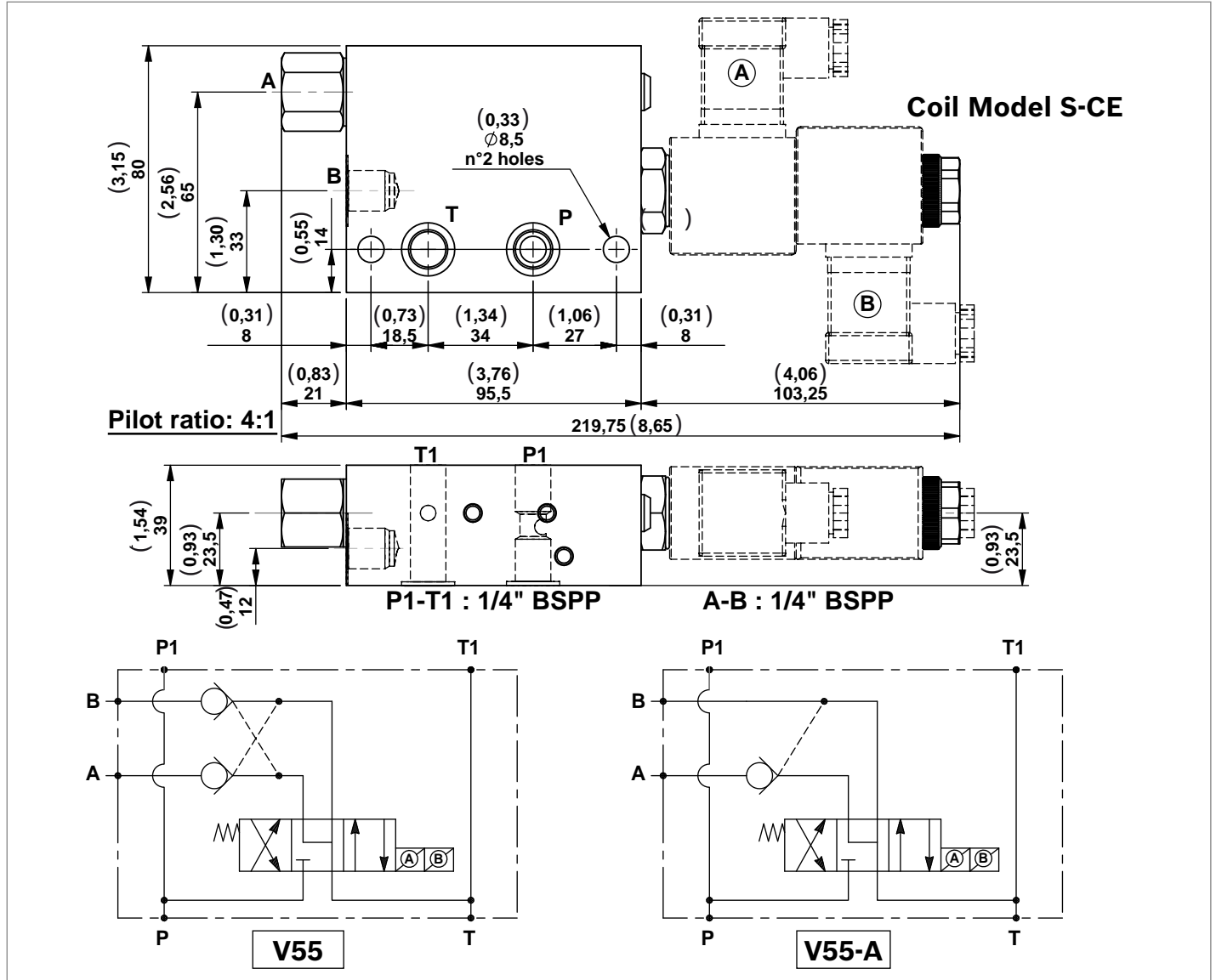

Code	Description	Max working pressure bar (psi)	Max flow l/min (gpm)	Type	Material number
V55	Modular block with 4 way 3 position solenoid valve and P.O. check valves on A and B <b>without O-Ring on pilot piston</b>	210 (3046)	8 (2,11)	G386591A10	R932001584
V55	Modular block with 4 way 3 position solenoid valve and P.O. check valves on A and B <b>with O-Ring on pilot piston</b>	210 (3046)	8 (2,11)	G386591B10	R932001589
V55/A	Modular block with 4 way 3 position solenoid valve and P.O. check valve on A <b>without O-Ring on pilot piston</b>	210 (3046)	8 (2,11)	G386591A1A	R932001581
V55/A	Modular block with 4 way 3 position solenoid valve and P.O. check valve on A <b>with O-Ring on pilot piston</b>	210 (3046)	8 (2,11)	G386591B1A	R932001586



**Modular block with four way three position solenoid valve and P.O. check valves on “A” and “B” line**

A modular block with 4/3 spool type solenoid valve and P.O. check valves on “A” and “B” line. For small double acting cylinders. Each block includes 2 OR 2056 gaskets.

Minimum voltage required: 90% of nominal.

Coils not included, must be ordered separately.

For the selection of coil model and voltage please refer to page 72.

For the selection of connectors please refer to page 75.

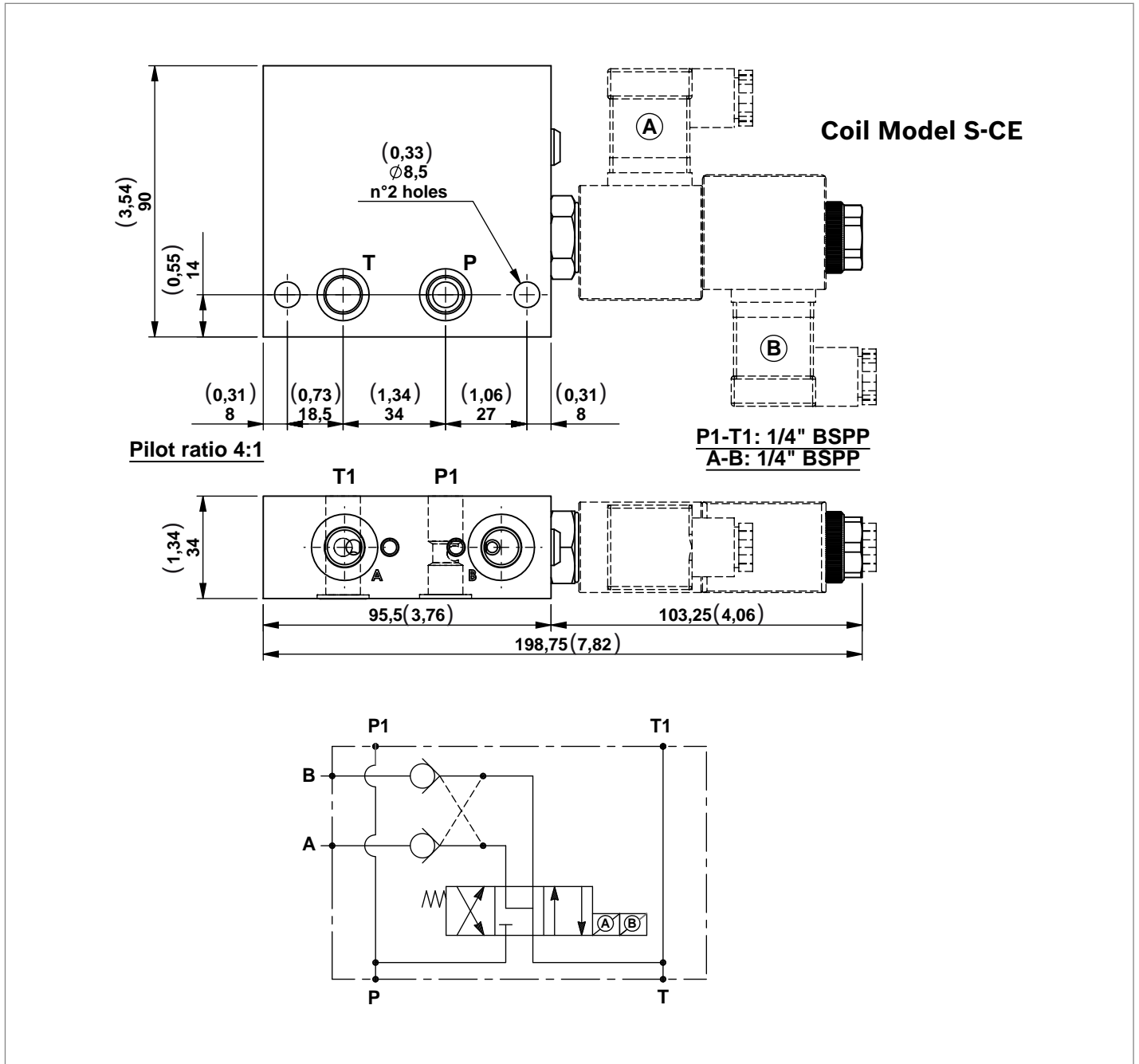

Code	Description	Max working pressure bar (psi)	Max flow l/min (gpm)	Type	Material number
V295	Modular block with four way three position solenoid valve and pilot operated check valves on "A" and "B" line	210 (3046)	8 (2,11)	1586500083	R932009708

**Modular blocks with double locking solenoid valve**

Each block includes 2 OR 2056 gaskets.

Coils not included, must be ordered separately.

For the selection of coil model and voltage please refer to page 72.

For the selection of connectors please refer to page 75.

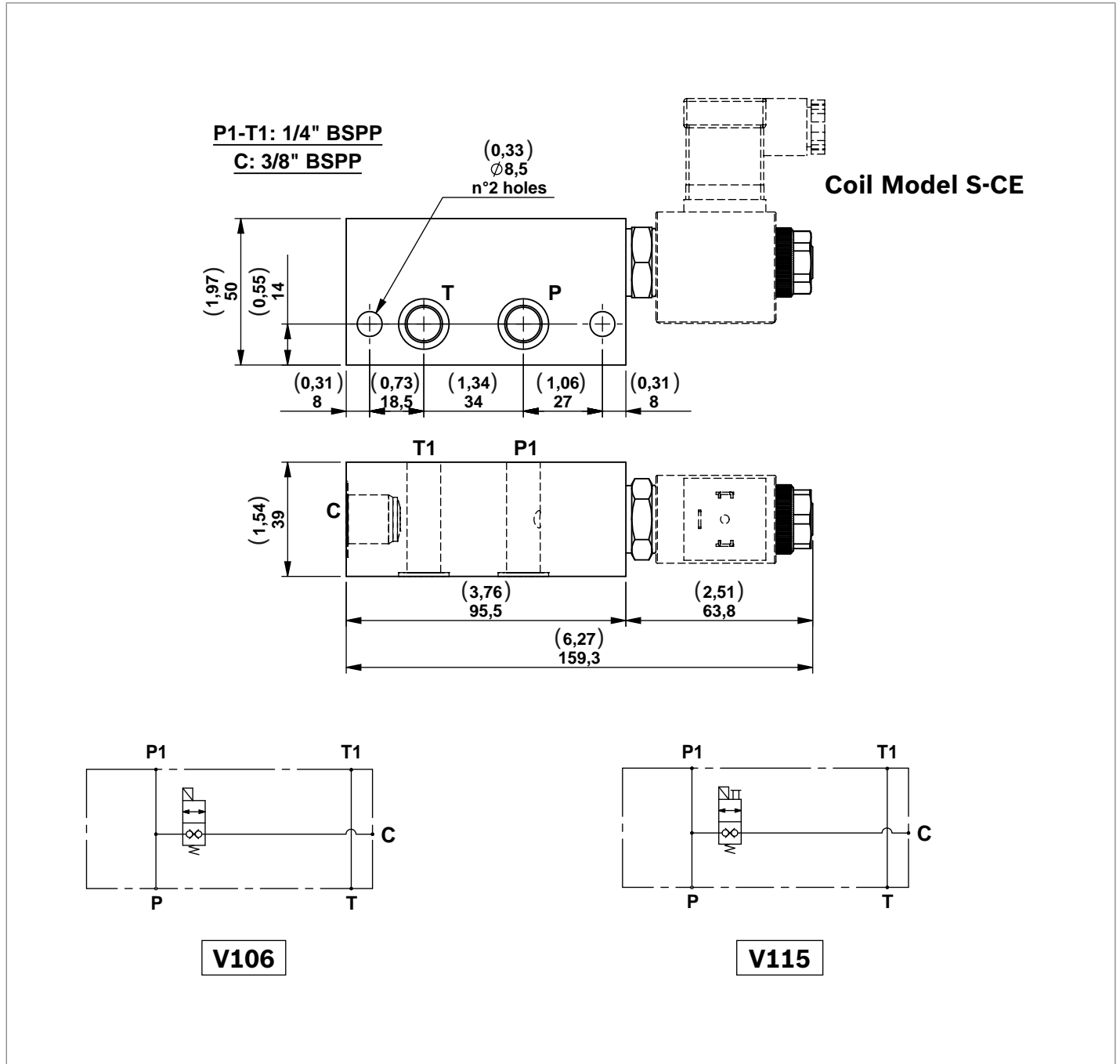

Code	Description	Max working pressure bar (psi)	Max flow l/min (gpm)	Type	Material number
<b>V106</b>	Modular block with CE3-DT solenoid valve	210 (3046)	16 (4,23)	G386606020	R932001613
<b>V115</b>	Modular block with CE3-DT-EM solenoid valve	210 (3046)	16 (4,23)	1586500023	R932004543

**Modular block with 2 double locking solenoid valves**

Each block includes 2 OR 2056 gaskets.

Coils not included, must be ordered separately.

For the selection of coil model and voltage please refer to page 72.

For the selection of connectors please refer to page 75.

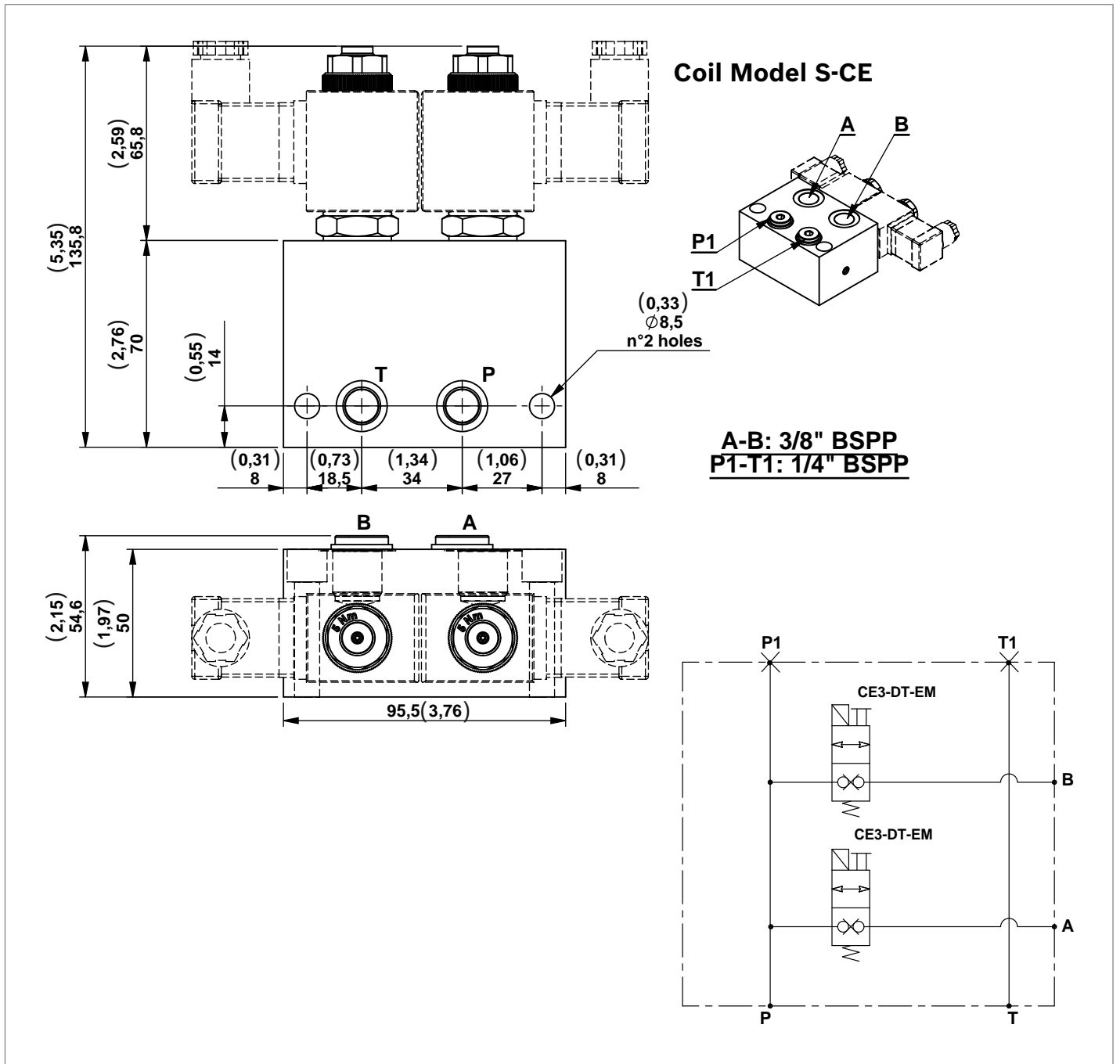

Code	Description	Max working pressure bar (psi)	Max flow l/min (gpm)	Type	Material number
V220	Modular block with 2 CE3-DT-EM with ports 3/8" BSPP	210 (3046)	16 (4,23)	1586500098	R932009614

**Modular block with 2 double locking solenoid valves**

Each block includes 2 OR 2056 gaskets.

Minimum voltage required: 90% of nominal.

Coils not included, must be ordered separately.

For the selection of coil model and voltage please refer to page 72.

For the selection of connectors please refer to page 75.

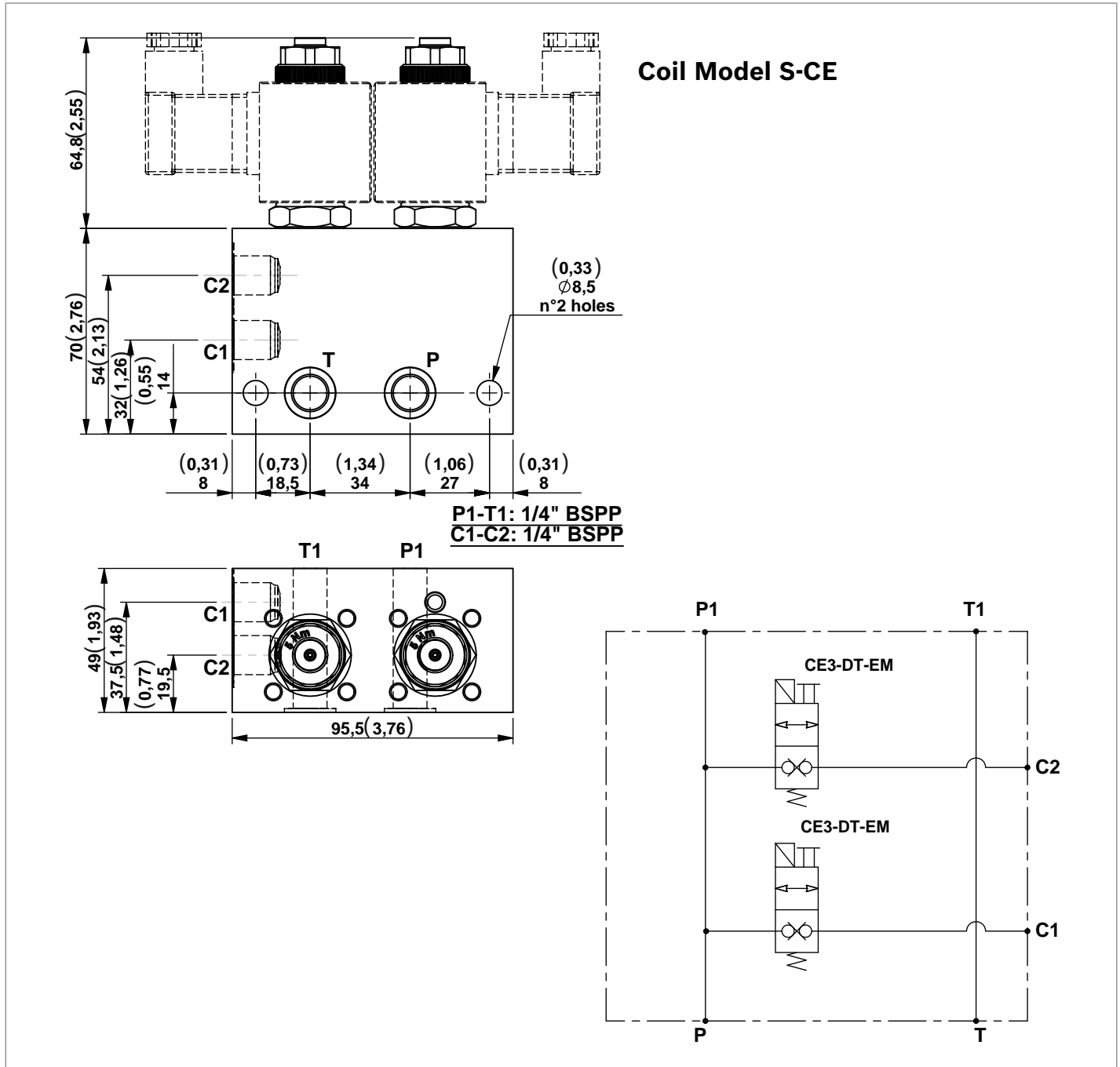

Code	Description	Max working pressure bar (psi)	Max flow l/min (gpm)	Type	Material number
V307	Modular block with 2 CE3-DT-EM with ports 1/4" BSPP	210 (3046)	16 (4,23)	1586500099	R932009709

**Modular block with 2 double locking solenoid valves**

Each block includes 2 OR 2056 gaskets.

Minimum voltage required: 90% of nominal.

Coils not included, must be ordered separately.

For the selection of coil model and voltage please refer to page 72.

For the selection of connectors please refer to page 75.

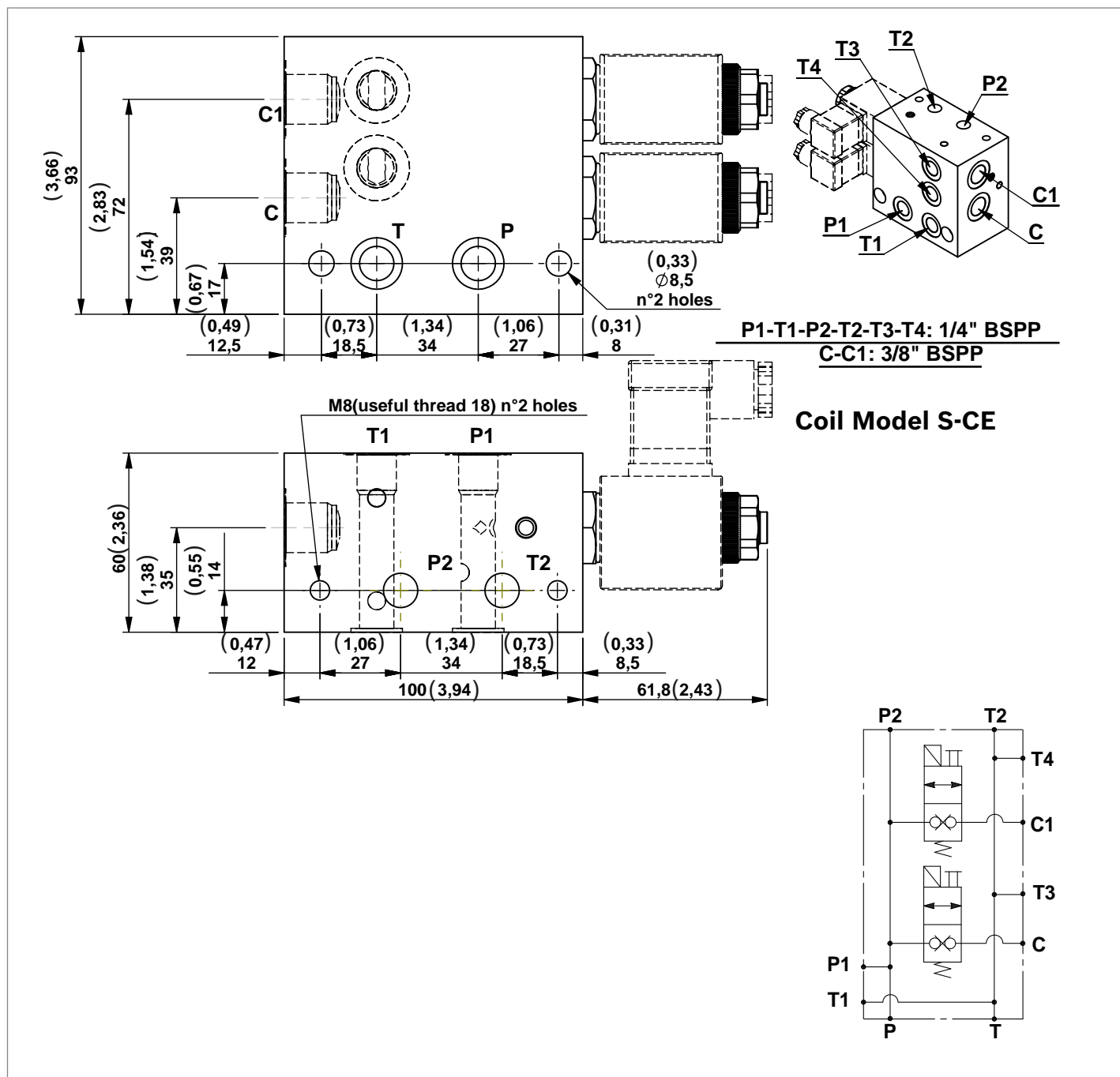

Code	Description	Max working pressure bar (psi)	Max flow l/min (gpm)	Type	Material number
V296	Modular block with 2 CE3-DT-EM with ports 3/8" BSPP and 2 auxiliary return ports	210 (3046)	16 (4,23)	1586500085	R932008993



### Accessories

#### Isolator

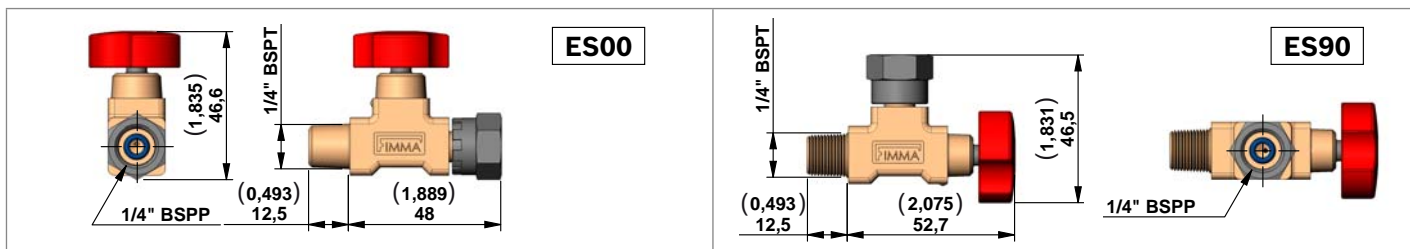

Code	Description	Type	Material Number
ES00	Straight isolator	EM 14	R932500182
ES90	90° isolator	EM 14 T	R932500184

#### Manometer

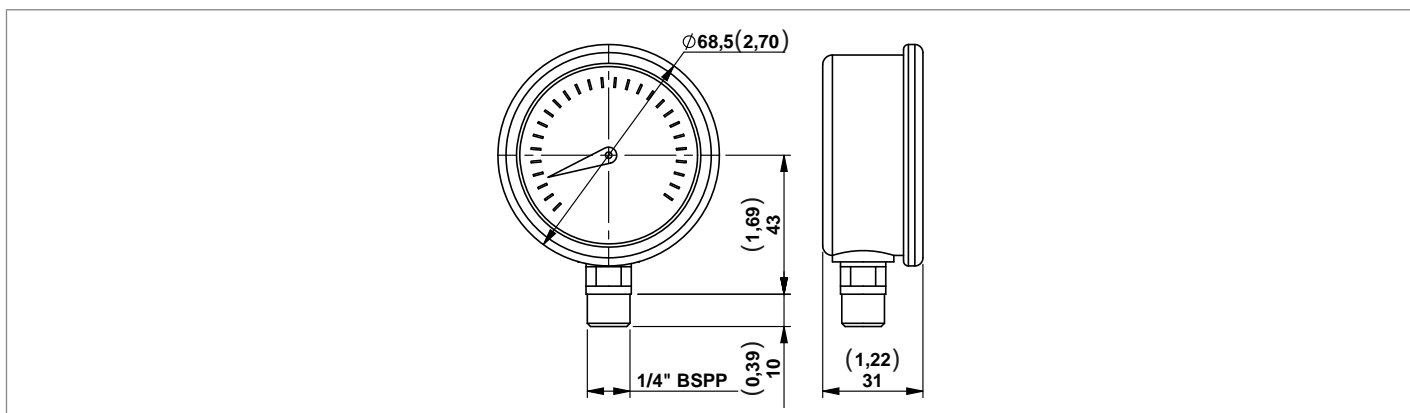

Code	Description	Pressure range bar (psi)	Type	Material Number
MN100	Pressure gauge	0-100 (0-1450)	C163017000	R932000582
MN160	Pressure gauge	0-160 (0-2320)	C163018000	R932000583
MN250	Pressure gauge	0-250 (0-3626)	C163019000	R932000584
MN315	Pressure gauge	0-315 (0-4568)	C163020000	R932000585

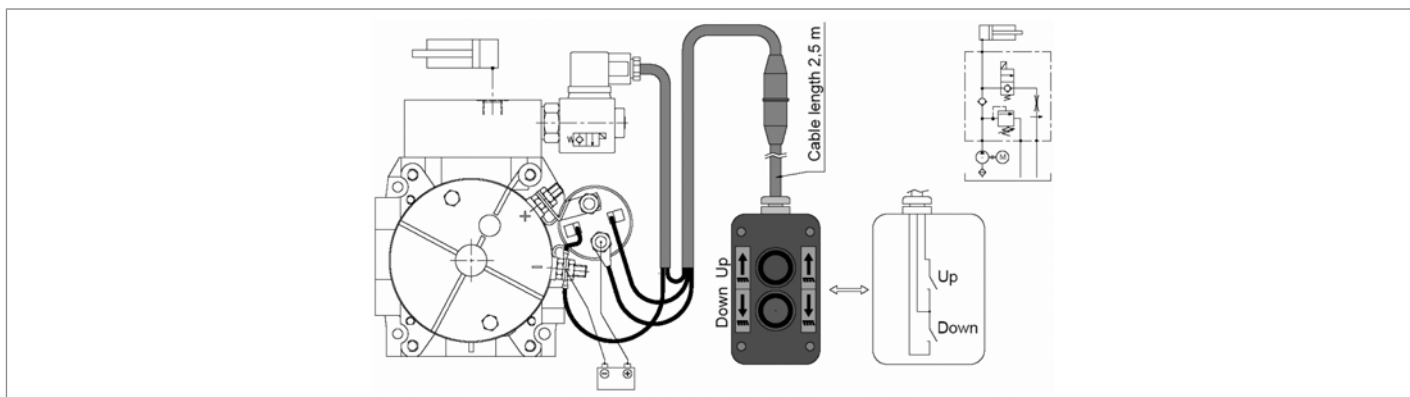

Description	Type	Material Number
Cables for D.C. motor and single acting cilinder	K2.501S1.218	R932002428

**Standard Pressure Switches**

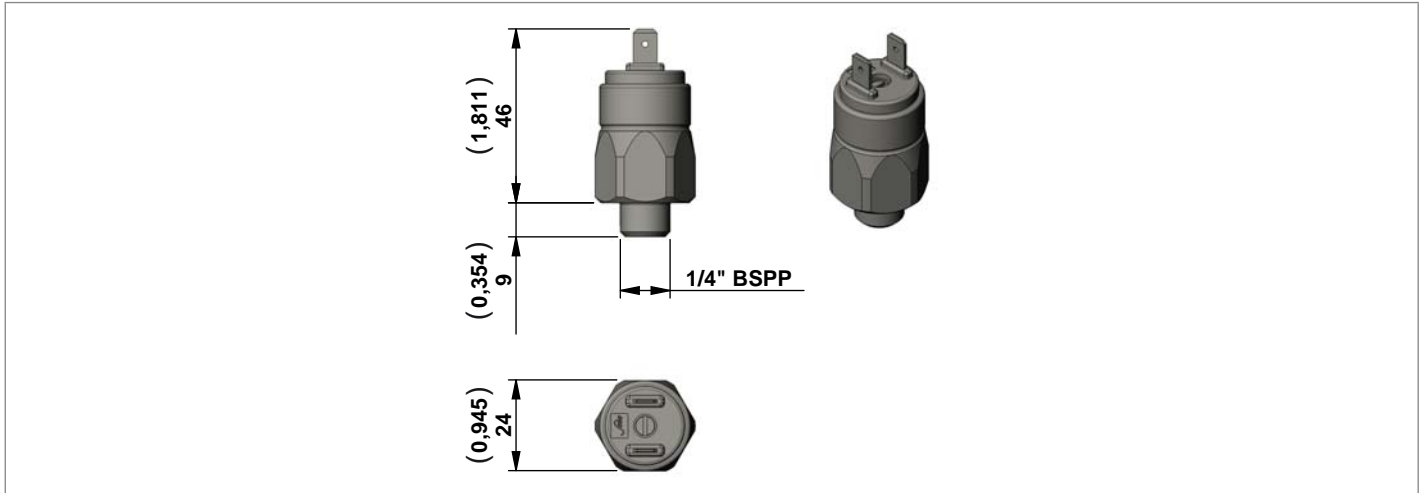

Code	Adjustment Range bar (psi)	Contact Type	Internal Features	Protection (with protective cap assembled)	Type	Material Number
<b>PRNO20</b>	10-20 (145-290)	N.O.	Diaphragm	IP65	C164761000	R932010002
<b>PRNC20</b>	10-20 (145-290)	N.C.	Diaphragm	IP65	C164766000	R932010001
<b>PRNO50</b>	20-50 (290-725)	N.O.	Diaphragm	IP65	C164767000	R932010003
<b>PRNC50</b>	20-50 (290-725)	N.C.	Diaphragm	IP65	C164768000	R932010004
<b>PRNO150</b>	50-150 (725-2175)	N.O.	Piston	IP65	C164769000	R932010005
<b>PRNC150</b>	50-150 (725-2175)	N.C.	Piston	IP65	C164770000	R932010006

**Protective Cap for Standard Pressure Switches**

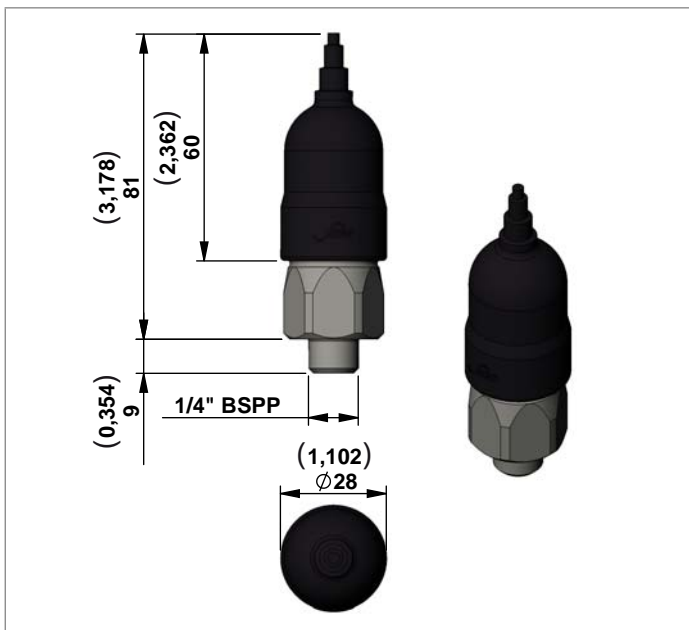

Code	Type	Material Number
<b>CAP</b>	F224013000	R932010000

**Pressure Switches for manifold A9**

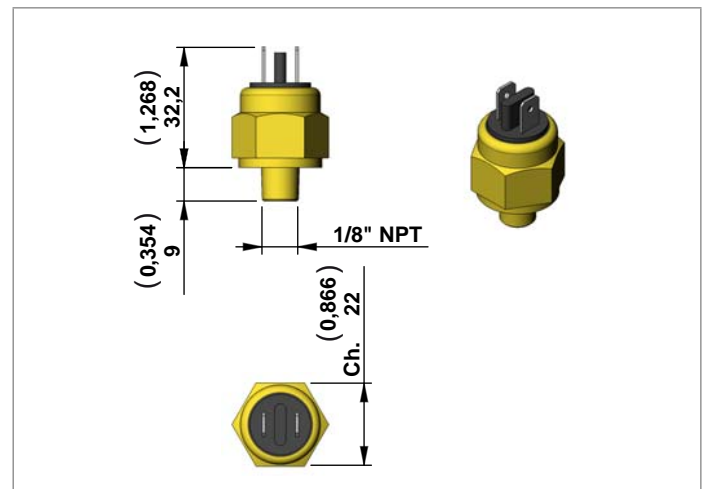

Code	Fixed Pressure Setting bar (psi)	Contact Type	Protection	Type	Material Number
<b>PRDU</b>	3 (44)	N.O.	IP00	C16470200A	R932008313



**Horizontal Suction, Plastic Pipe**

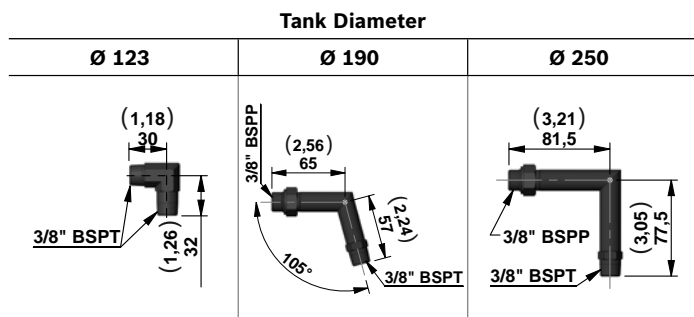

Central Manifold	Oil tank diameter mm (inch)	Type	Material Number
<b>K</b>	123 (4,84)	K2340S2144	R932006770
	190 (7,48)	K2501S1060	R932002408
	250 (9,84)	K2501S1061	R932002409

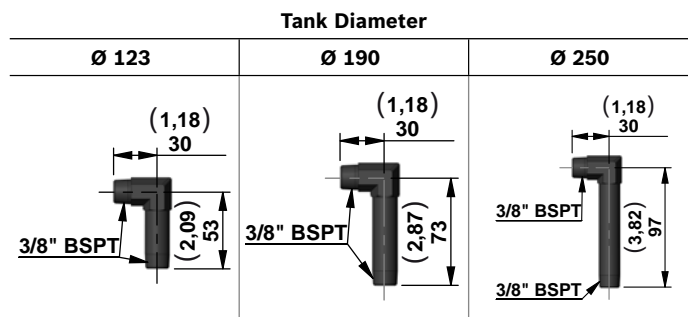

Central Manifold	Oil tank diameter mm (inch)	Type	Material Number
<b>KE</b>	123 (4,84)	K2340S2145	R932006771
	190 (7,48)	K2340S2146	R932006772
	250 (9,84)	K2340S2147	R932006773

**Vertical Suction, Plastic Pipe**

Central Manifold	H mm (inch)	Type	Material Number	Drawing ref.	Drawing
<b>KE - K</b>	32 (1,26)	K234069000	R932002347	B	
	33 (1,30)	K2340S2130	R932002303	A	
	36 (1,42)	K2340S2123	R932002299	A	
	45 (1,77)	K2340S2118	R932002297	A	
	47 (1,85)	K234073000	R932002349	B	
	56 (2,20)	K2340S2129	R932002302	A	
	67 (2,64)	K2340S2131	R932002304	A	
	76 (2,99)	K234074000	R932002350	B	
	98 (3,86)	K234076000	R932002351	B	
	107 (4,21)	K2340S2133	R932002306	A	
	109 (4,29)	K234079000	R932002352	B	
	117 (4,61)	K2340S2110	R932002289	A	
	129 (5,08)	K234072000	R932002348	B	
	130 (5,12)	K2340S2121	R932002298	A	
	144 (5,67)	K234063000	R932002343	B	
	153 (6,02)	K2340S2134	R932002307	A	
	163 (6,42)	K2340S2135	R932002308	A	
	171 (6,73)	K2340S2111	R932002290	A	
	178 (7,01)	K2340S2136	R932002309	A	
	194 (7,64)	K234066000	R932002345	B	
	198 (7,79)	K2340S2137	R932002310	A	
	211 (8,31)	K234064000	R932002344	B	
	218 (8,58)	K2340S2125	R932002300	A	
	233 (9,17)	K2340S2112	R932002291	A	
	241 (9,49)	K2340S2138	R932002311	A	
	251 (9,88)	K2340S2139	R932002312	A	
	280 (11,02)	K2340S2113	R932002292	A	
	293 (11,53)	K2340S2140	R932002313	A	
	313 (12,32)	K2340S2114	R932002293	A	
	330 (12,99)	K2340S2115	R932002294	A	
341 (13,42)	K2340S2141	R932002314	A		
351 (13,82)	K2340S2116	R932002295	A		
369 (14,53)	K2340S2142	R932002315	A		
378 (14,88)	K2340S2117	R932002296	A		
398 (15,67)	K2340S2128	R932002301	A		

**Vertical Suction, Steel Pipe**

Central Manifold	H mm (inch)	Type	Material Number	Drawing
KE - K	86 (3,39)	K234006000	R932009324	
	100 (3,94)	K234081000	R932002353	
	110 (4,33)	K234083000	R932002355	
	117 (4,61)	K2340S2162	R932009323	
	150 (5,91)	K234004000	R932002317	
	160 (6,30)	K2340S2151	R932008456	
	178 (7,01)	K234086000	R932002356	
	212 (8,35)	K234093000	R932002360	
	260 (10,24)	K234087000	R932002357	
	287 (11,30)	K234071000	R932006600	
	348 (13,70)	K2340S2027	R932002272	
	357 (14,05)	K234092000	R932002359	
	385 (15,16)	K234062000	R932002342	
	520 (20,47)	K2340S2047	R932008033	

**Suction Filter**

Compatibility	Filtering Degree (µm)	Max Flow l/min (gpm)	Type	Material Number	Drawing
KE - K	90	8 (2,11)	K225582000	R932010860	
	90	15 (3,96)	K225566000	R932002243	

**Horizontal Return, Steel Pipe**

L mm (inch)	H mm (inch)	Type	Material Number	Drawing
120 (4,72)	45 (1,77)	K234716000	R932002375	
134 (5,28)	90 (3,54)	K234717000	R932002376	
170 (6,69)	90 (3,54)	K234727000	R932002383	

**Vertical Return, Plastic Pipe**

H mm (inch)	Type	Material Number	Drawing ref.	Drawing
100 (3,94)	K234715000	R932002374	A	
110 (4,33)	K234780000	R932011081	B	
120 (4,72)	K234781000	R932011082	B	
150 (5,91)	K234714000	R932002373	A	
160 (6,30)	K234782000	R932011083	B	
200 (7,87)	K234713000	R932002372	A	
250 (9,84)	K234784000	R932011084	B	
300 (11,81)	K234785000	R932011085	B	
400 (15,75)	K234786000	R932011086	B	

**Vertical Return, Steel Pipe**

H mm (inch)	Type	Material Number	Drawing
250 (9,84)	K234718000	R932002377	
300 (11,81)	K234719000	R932002378	
400 (15,75)	K234722000	R932002379	

**Bosch Rexroth Oil Control S.p.A.**

Oil Sistem Division  
Via Artigianale Sedrio, 12  
42030 Vezzano sul Crostolo  
Reggio Emilia - Italy  
Tel. +39 0522 601 801  
Fax +39 0522 606 226 / 601 802  
compact-hydraulics-cpm@boschrexroth.com  
www.boschrexroth.com/compacthydraulics

© This document, as well as the data, specifications and other information set forth in it, are the exclusive property of Bosch Rexroth Oil Control S.p.a.. It may not be reproduced or given to third parties without its consent. The data specified above only serve to describe the product. No statements concerning a certain condition or suitability for a certain application can be derived from our information. The information given does not release the user from the obligation of own judgment and verification. It must be remembered that our products are subject to a natural process of wear and aging.  
Subject to change.