

# Compact power pack program

RE 00163/08.06

The Drive & Control Company



# Compact power pack modular system

Compact power packs are available with standard components in 6 versions: ME, K, KE, KS, ZL and IM. Further customized versions can be developed from customer requirements.

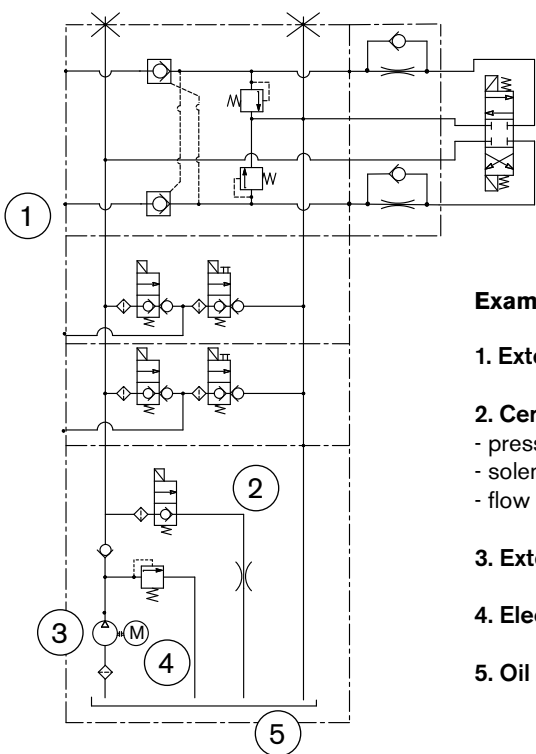
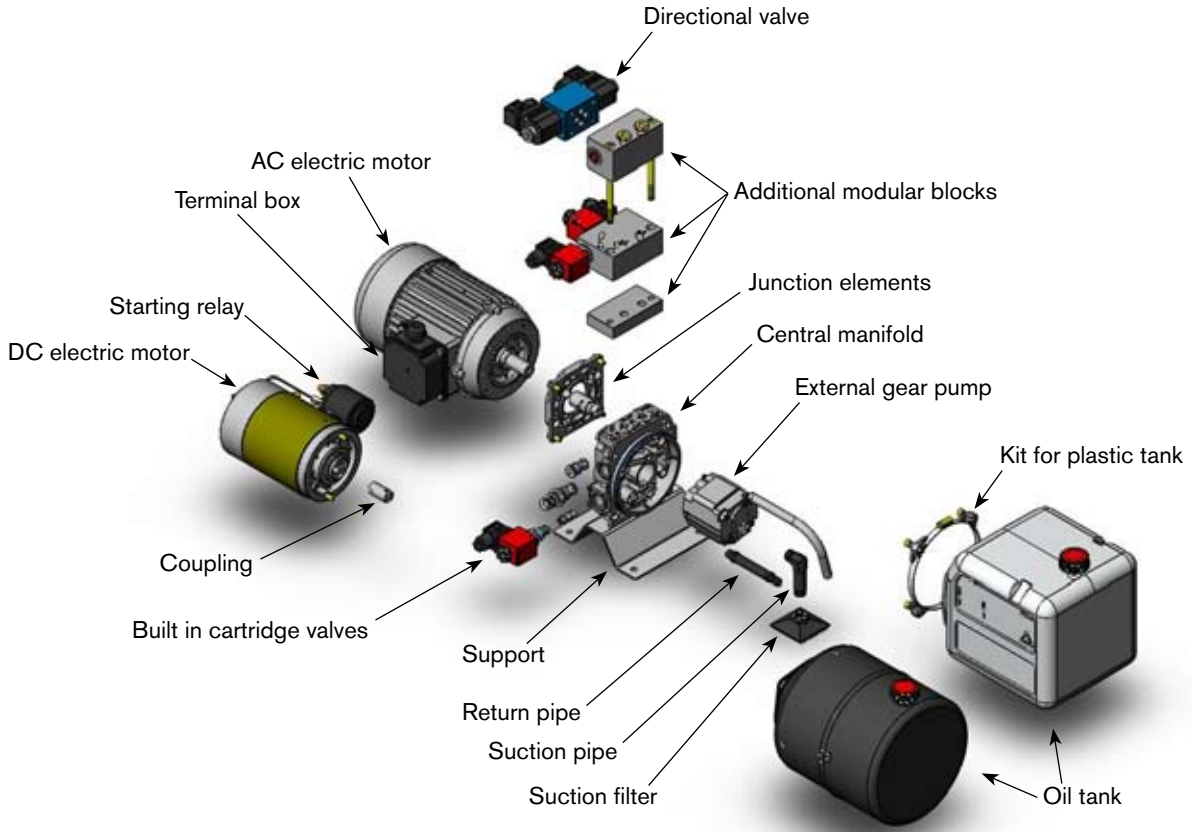

### Example of hydraulic circuit

- 1. External modular blocks**
- 2. Central manifold with built in valves:**
  - pressure relief valve
  - solenoid operated 2/2 valve
  - flow regulator valve
- 3. External gear pump**
- 4. Electric motor**
- 5. Oil reservoir**

# Applications

Compact power packs are suitable for industrial or mobile applications using operating pressures up to 300 bar (4350 psi). Thanks to the modular design of compact power packs, they can be used for a virtually unlimited number of customized applications. The principle uses of compact power packs are, among others: in material handling and warehouse equipment, docking equipment, car lifts for garages, human lifting applications, building cranes, machining tools.



Material handling



Dock levellers



Tail gate lifts



Car lifts



Passenger lifts



Truck mounted cranes



Home lifts



Aerial platforms



Tyre changers



Table lifts



Dumpers



Building cranes



Nautical applications



Hydraulic presses

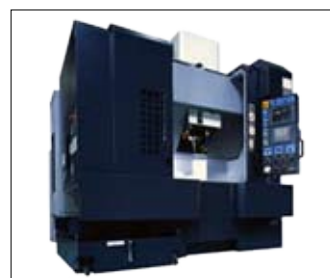

Machining tools



Foods machinery



# Product range



## ME

### Smallest overall dimensions

- **DC and AC electric motors**  
DC 12/24V up to 2200 W  
AC single or 3-phase up to 1100 W (1,5 hp)
  - **Pressures up to 250 bar (3625 psi)**
  - **Pump displacement up to 1,5 cm<sup>3</sup> (0,09 in<sup>3</sup>)**
  - **Flows @ 1500 rpm up to 2,25 l/min (0,6 gpm)**
- *Reduce the space.*
  - *Solenoid operated cartridge valve 3/4"-16 UNF inside.*
  - *Manometer port 1/8".*
  - *Modular interface.*
  - *Optional reversible pump.*



## K

### Standard applications

- **DC and AC electric motors**  
DC 12/24V up to 3000 W  
AC single or 3-phase up to 4000 W (5,5 hp)
  - **Pressures up to 300 bar (4350 psi)**
  - **Pump displacement up to 9,9 cm<sup>3</sup> (0,6 in<sup>3</sup>)**
  - **Flows @ 1500 rpm up to 14,8 l/min (3,91 gpm)**
- *Ideal for dealers.*
  - *Solenoid operated cartridge valve 3/4"-16 UNF inside.*
  - *Manometer port 1/4".*
  - *Modular interface.*
  - *Hand pump 1,5 cc or hand operated valve inside.*
  - Optionals:*
    - *reversible pump;*
    - *double pump;*
    - *elastic coupling.*



## KE

### Complex circuits, direct flange AC motors

- **DC and AC electric motors**  
DC 12/24V up to 3000 W  
AC single or 3-phase up to 4000 W (5,5 hp)
  - **Pressures up to 300 bar (4350 psi)**
  - **Pump displacement up to 9,9 cm<sup>3</sup> (0,6 in<sup>3</sup>)**
  - **Flows @ 1500 rpm up to 14,8 l/min (3,91 gpm)**
- *More cavities for complex circuits.*
  - *Solenoid operated cartridge valve 3/4"-16 UNF inside.*
  - *Modular interface.*
  - *Hand pump 1,5 cc or hand operated valve inside.*
  - Optionals:*
    - *start-up valve;*
    - *4 ways solenoid operated valve 3/4"-16 UNF or 7/8"-14 UNF inside;*
    - *direct flange AC motors for compact mounting style.*





## KS

### Designed for lifting applications

- **DC and AC electric motors**  
DC 12/24V up to 3000 W  
AC single or 3-phase up to 4000 W (5,5 hp)
- **Pressures up to 300 bar (4350 psi)**
- **Pump displacement up to 9,9 cm<sup>3</sup> (0,6 in<sup>3</sup>)**
- **Flows @ 1500 rpm up to 14,8 l/min (3,91 gpm)**

- *Standard for forklift and pallet stacker application.*
- *Solenoid operated cartridge valve 3/4"-16 UNF inside.*
- *Auxiliary pressure port.*
- *Flow control valve.*
- Optionals:*
  - *automatic unloading valve;*
  - *proportional valve.*



## ZL

### Industrial applications

- **AC electric motors**  
AC single or 3-phase up to 7500 W (10 hp)
- **Pressures up to 300 bar (4350 psi)**
- **Pump displacement up to 22,8 cm<sup>3</sup> (1,39 in<sup>3</sup>)**
- **Flows @ 1500 rpm up to 51,7 l/min (13,66 gpm)**

- *High power AC electric motors.*
- *Pump and motor compact mounting with minimal piping.*
- *Modular interface.*
- *Elastic coupling.*

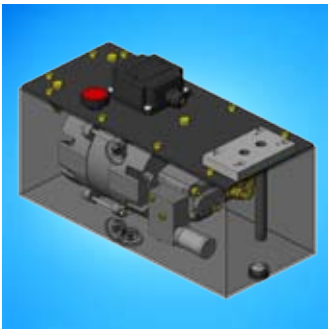

## IM

### Oil immersed motor

- **AC electric motors**  
AC single or 3-phase up to 5200 W (7 hp)
- **Pressures up to 300 bar (4350 psi)**
- **Pump displacement up to 22,8 cm<sup>3</sup> (1,39 in<sup>3</sup>)**
- **Flows @ 1500 rpm up to 34,2 l/min (9,03 gpm)**

- *Oil immersed AC electric motor to reduce noise and space.*
- *Modular interface on top cover.*
- Optionals:*
  - *reversible pump;*
  - *double pump.*



## ME | Smallest overall dimensions

### Main features:

- DC motors up to 2,2 kW for intermittent operation duty cycle (S3).
- AC motors single-phase or 3-phase, 2 or 4 poles up to 1,1 kW for continuous duty cycle (S1).
- External gear pumps up to 1,5 cm<sup>3</sup>/rev (0,09 in<sup>3</sup>/rev).
- Pressures up to 250 bar (3625 psi).
- Reduce the space.
- Solenoid operated cartridge valve 3/4"-16 UNF inside the central block.
- Manometer port 1/8"BSPP.
- Modular interface.

### Optionals:

- reversible pump.



## Modular blocks

More complex driving circuits can be realized with the addition of external blocks over the central manifold.

All the blocks have the same interface with a given distance between P - T ports and threads for screws.

Please refer to modular blocks catalogue to learn which type of circuits are available.

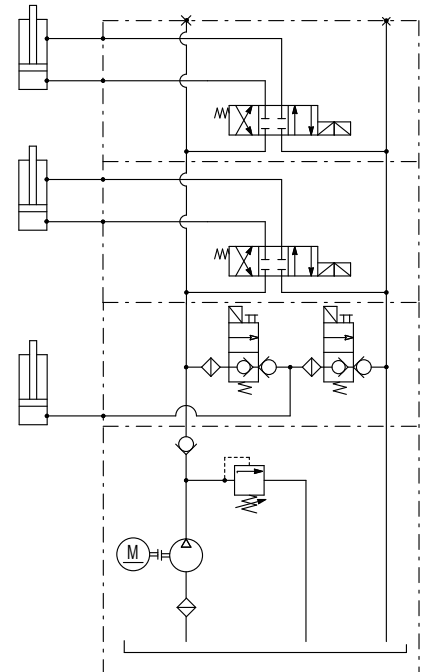
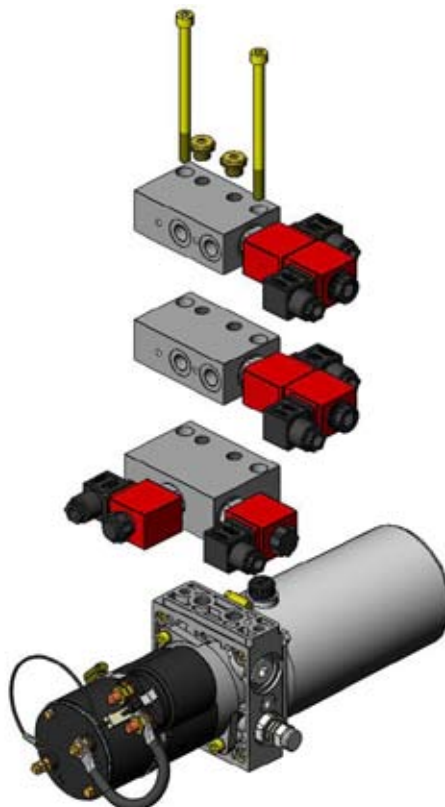

Example: external modular elements for single acting cylinder and 2x elements for double acting cylinder with 4/3 solenoid operated cartridge valves.

## Examples of hydraulic circuits

The following selection of commonly used circuits can be accomplished by the use of the central manifold only. Please note that names identify the type of central manifold with its cavities, but not the unique realizable circuit diagram. For example M54 means central manifold ME-type with cavities for pressure relief valve, check valve, flow regulator and 4 ways valve; then you can fill cavities with valves or plugs.

### M52/M53 Standard circuits

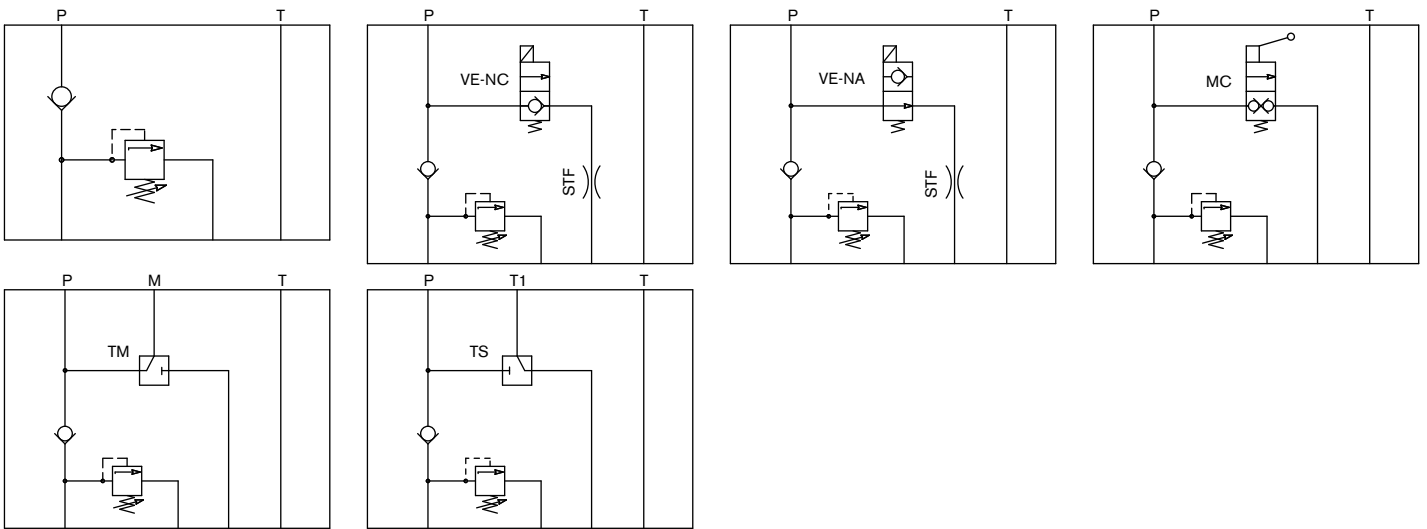

### M55/M57 Standard circuits with manometer port

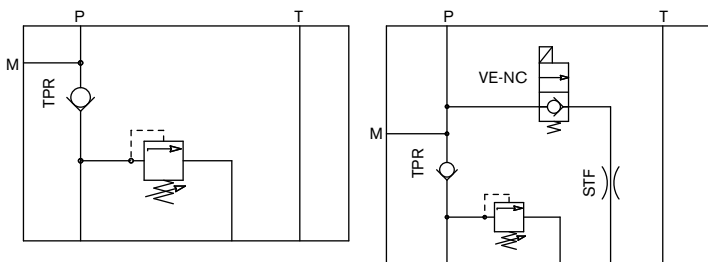

### M54 4 ways valve

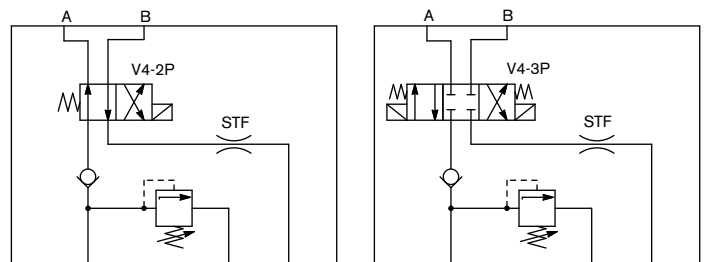

### M58 4 ways with manometer port

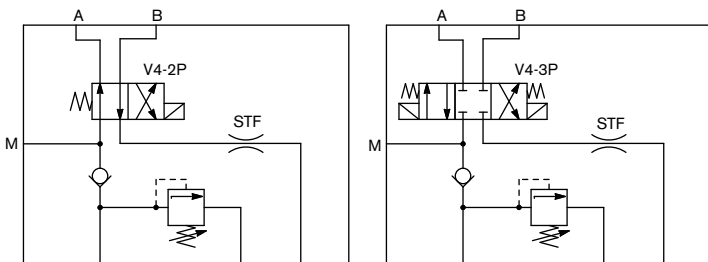

### Reversible pump

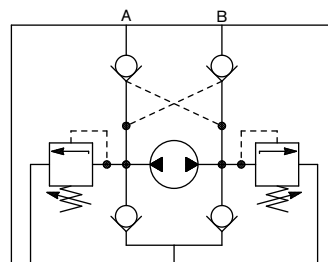

#### Notes

- M52/M55 without modular interface, smaller dimension
- M53/M57 with modular interface
- M54/M58 modular interface is not available with 4 ways valve
- 4 ways valve is available with different symbols.
- Please refer to the catalogue to learn which symbols are available.

## K | Designed for standard applications

### Main features:

- *DC motors up to 3,0 kW for intermittent operation duty cycle (S3).*
- *AC motors single-phase or 3-phase, 2 or 4 poles up to 4,0 kW for continuous duty cycle (S1).*
- *External gear pumps up to 9,9 cm<sup>3</sup>/rev (0,6 in<sup>3</sup>/rev).*
- *Pressures up to 300 bar (4350 psi).*
- *Ideal for dealers.*
- *Solenoid operated or hand operated cartridge valve 3/4"-16 UNF inside the central block.*
- *Manometer port 1/4"BSPP.*
- *Modular interface.*
- *Hand pump 1,5 cm<sup>3</sup> inside the central block.*

### Optionals:

- *reversible pump;*
- *double pump with one common pressure line, or two independent pressure lines;*
- *elastic coupling to assure best performance for heavy duty applications, with low noise levels.*



## Modular blocks

More complex driving circuits can be realized with the addition of external blocks over the central manifold.

All the blocks have the same interface with a given distance between P - T ports and threads for screws.

Please refer to modular blocks catalogue to learn which type of circuits are available.

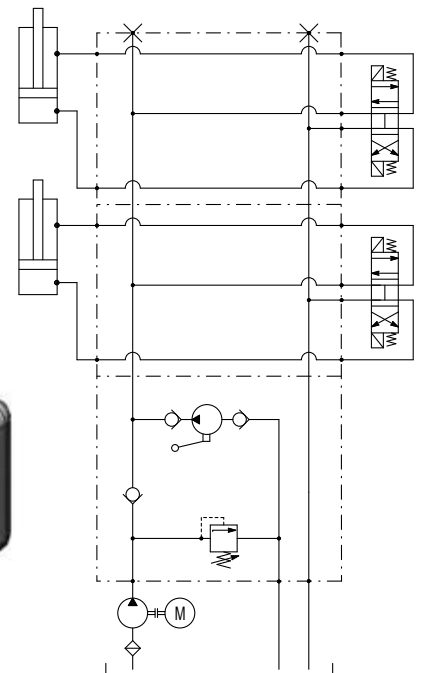
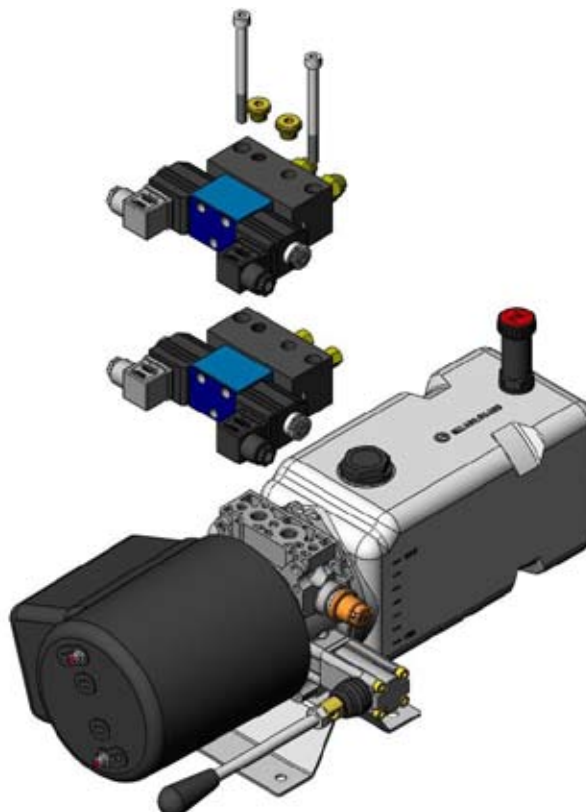

Example: external modular elements with standard DIN24340-NG6 ISO/CETOP3 valves.



## Examples of hydraulic circuits

The following selection of commonly used circuits can be accomplished by the use of the central manifold only. Please note that names identify the type of central manifold with its cavities, but not the unique realizable circuit diagram. For example A12 means central manifold K-type with cavities for pressure relief valve, check valve, flow regulator and 2/2 cartridge valve; then you can fill cavities with valves or plugs.

### A1 Basic circuits

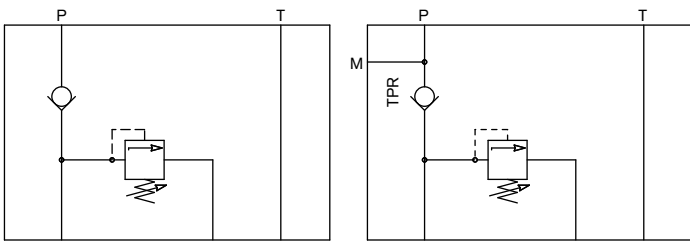

### A12/A16 Standard circuits

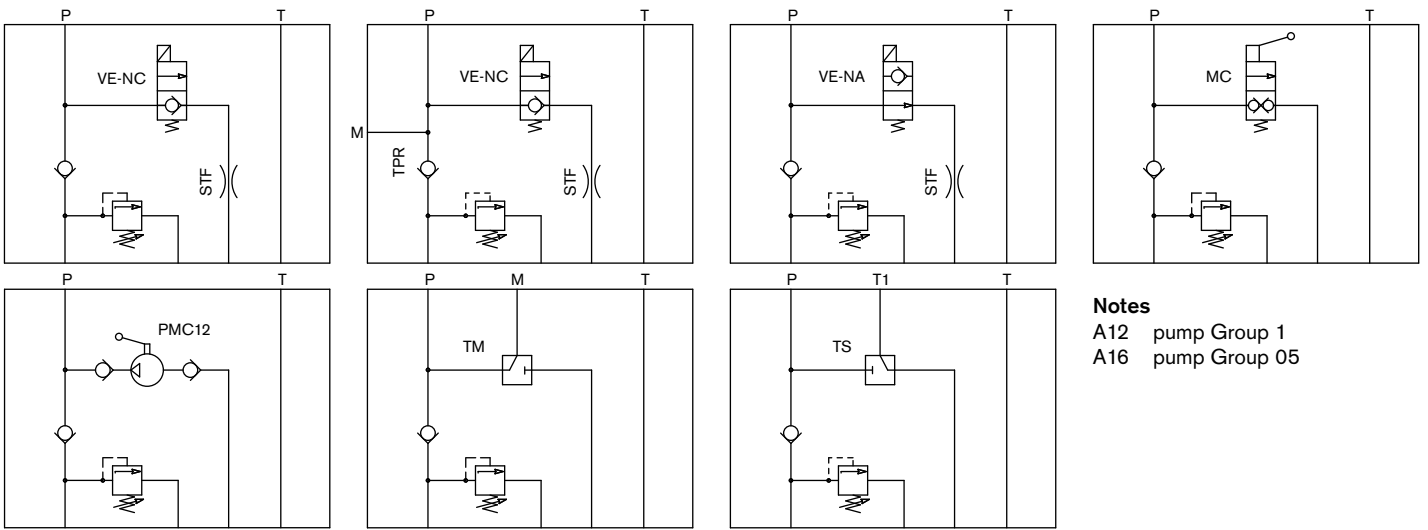

**Notes**  
 A12 pump Group 1  
 A16 pump Group 05

### A14 Adjustable flow regulator

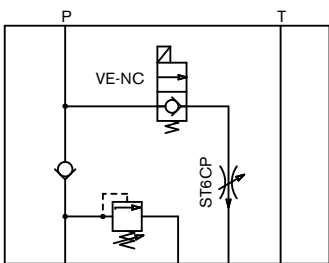

### Reversible pump

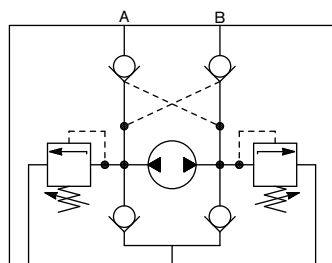

### Double pump

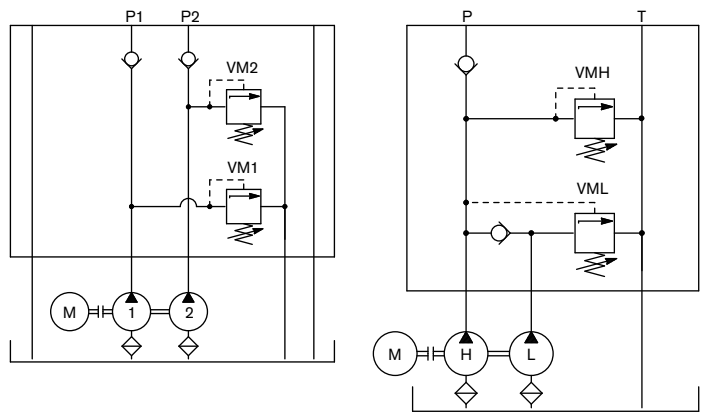

## KE | Designed for complex circuits, direct flange AC motors

### Main features:

- DC motors up to 3,0 kW for intermittent operation duty cycle (S3).
- AC motors single-phase or 3-phase, 2 or 4 poles up to 4,0 kW for continuous duty cycle (S1).
- External gear pumps up to 9,9 cm<sup>3</sup>/rev (0,6 in<sup>3</sup>/rev).
- Pressures up to 300 bar (4350 psi).
- More cavities for complex circuits.
- Solenoid operated or hand operated cartridge valve 3/4"-16 UNF inside the central block.
- Modular interface.
- Hand pump 1,5 cm<sup>3</sup> inside the central block.

### Optionals:

- start-up valve for AC single-phase motors;
- 4 ways solenoid operated valve 3/4"-16 UNF or 7/8"-14 UNF inside the central block;
- direct flange AC motor for compact mounting style.



## Modular blocks

More complex driving circuits can be realized with the addition of external blocks over the central manifold.

All the blocks have the same interface with a given distance between P - T ports and threads for screws.

Please refer to modular blocks catalogue to learn which type of circuits are available.

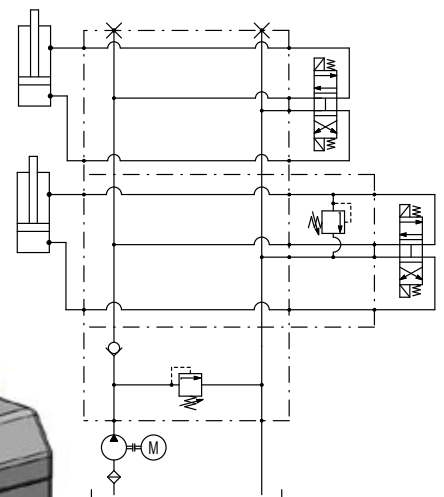
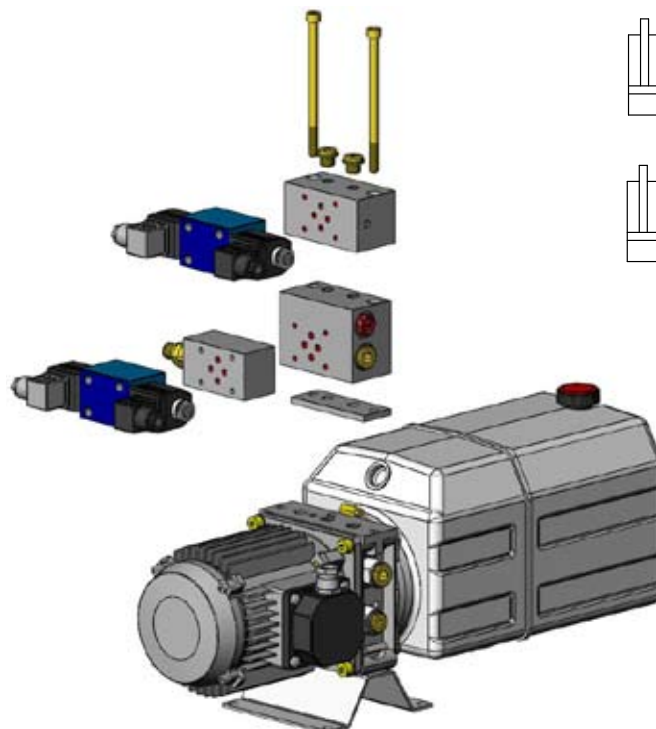

Example: external modular elements with pressure relief valve and standard DIN24340-NG6 ISO/CETOP3 valves.

## Examples of hydraulic circuits

The following selection of commonly used circuits can be accomplished by the use of the central manifold only. Please note that names identify the type of central manifold with its cavities, but not the unique realizable circuit diagram. For example M02 means central manifold KE-type with cavities for pressure relief valve, check valve, flow regulator and 2/2 valve; then you can fill cavities with valves or plugs.

### M02 Standard circuits

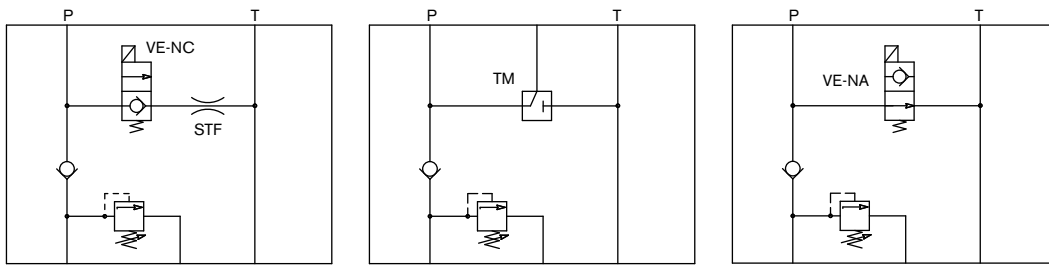

### M03 Adjustable flow regulator

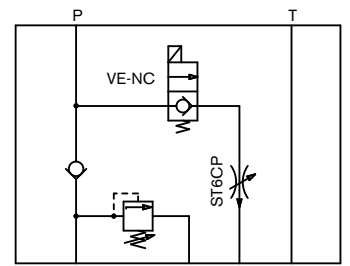

### M04 Complex circuits, modular interface

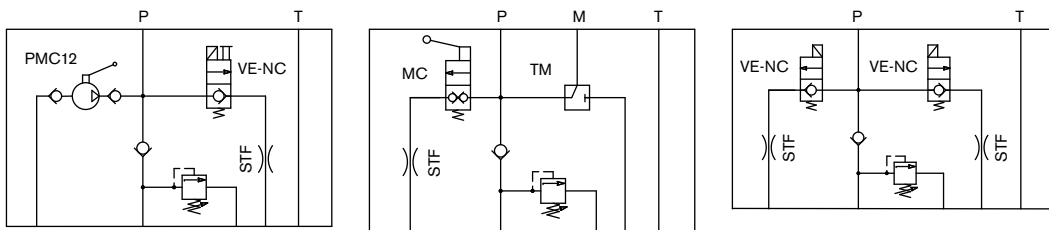

### M05 Complex circuits

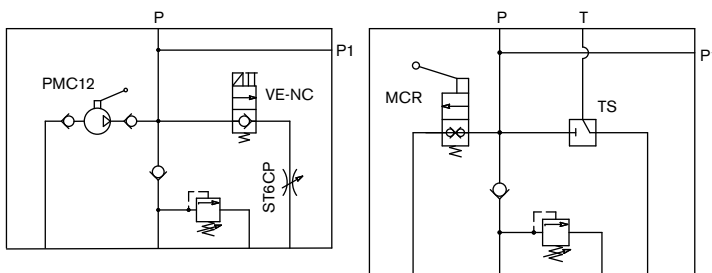

### M15/M16 3 ways valve

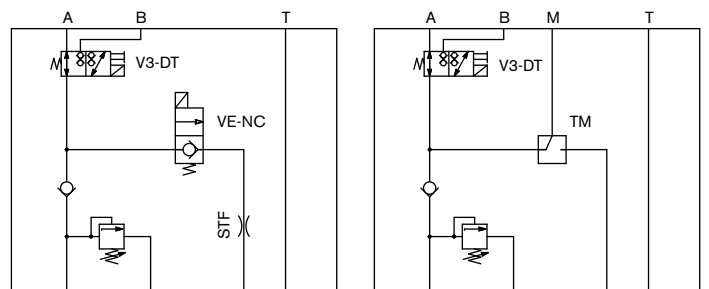

### M09 Start-up, modular interface

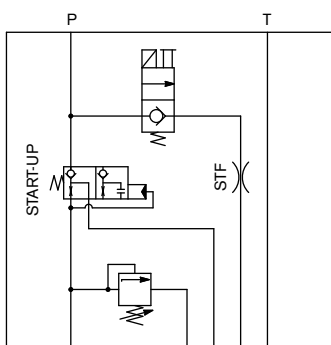

### M19 Start-up

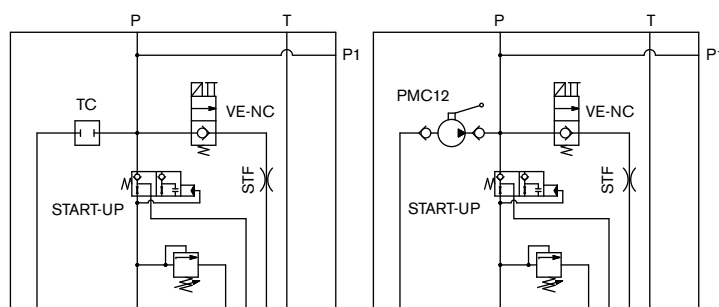

### M21/M25 4 ways valve

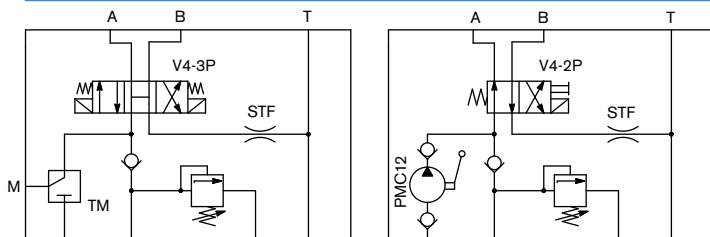

#### Notes

- M15 = T, A and B ports are on the same side.
- M16 = T and B are on the same side, but A rotated 90°.
- M21 = cavity 3/4"-16 UNF.
- M25 = cavity 7/8"-14 UNF.
- 4 ways valve is available with different symbols.
- Please refer to the catalogue to learn which symbols are available.

## KS | Designed for lifting applications

### Main features:

- DC motors up to 3,0 kW for intermittent operation duty cycle (S3).
- AC motors single-phase or 3-phase, 2 or 4 poles up to 4,0 kW for continuous duty cycle (S1).
- External gear pumps up to 9,9 cm<sup>3</sup>/rev (0,6 in<sup>3</sup>/rev).
- Pressures up to 300 bar (4350 psi).
- Standard for fork-lift and pallet-stacker applications.
- Solenoid operated cartridge valve 3/4"-16 UNF inside the central block.

### Optionals:

- proportional directional valve;
- piloted unloading valve.



## Examples of hydraulic circuits

The following selection of commonly used circuits can be accomplished by the use of the central manifold only. Please note that names identify the type of central manifold with its cavities, but not the unique realizable circuit diagram. For example KS00 means central manifold KS-type with cavities for pressure relief valve, flow regulator, check valve and 2/2 valve; then you can fill cavities with valves or plugs.

**KS00** Standard circuit

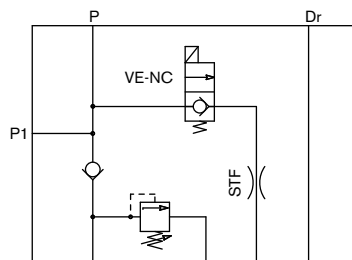
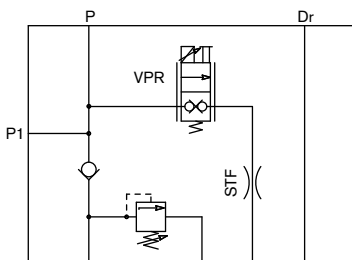

**KS02** Piloted unloading valve

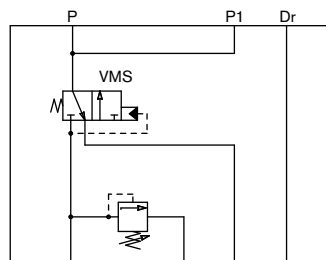



## ZL | Industrial applications

### Main features:

- AC motors single-phase or 3-phase, 2 or 4 poles up to 7,5 kW for continuous duty cycle (S1).
- External gear pumps up to 22,8 cm<sup>3</sup>/rev (1,39 in<sup>3</sup>/rev).
- Pressures up to 300 bar (4350 psi).
- High power AC electric motors.
- Pump and motor compact mounting with central block.
- Elastic coupling.
- Modular interface.

### Examples of hydraulic circuits

The following selection of commonly used hydraulic circuits can be accomplished by the use of the central manifold only.

#### 01 Standard circuit

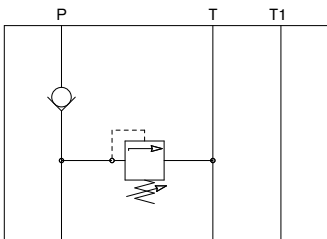

#### 02

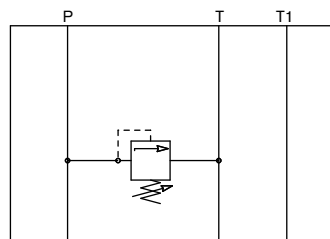

#### 04

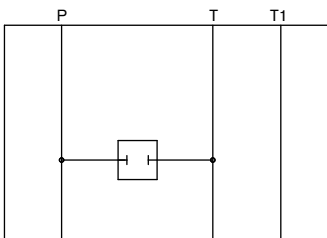

### Modular blocks

More complex driving circuits can be realized with the addition of external blocks over the central manifold.

All the blocks have the same interface with a given distance between P - T ports and threads for screws.

Please refer to modular blocks catalogue to learn which type of circuits are available.

*Example: external modular elements with cartridge valves and hand pump.*

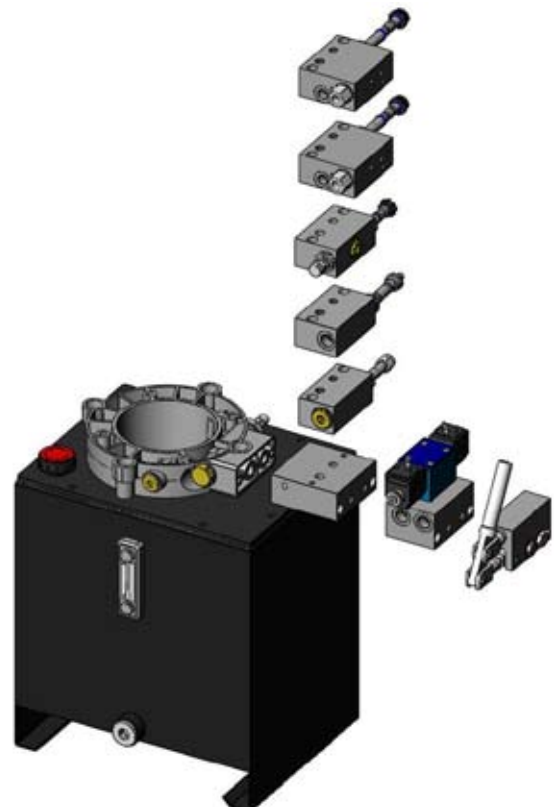
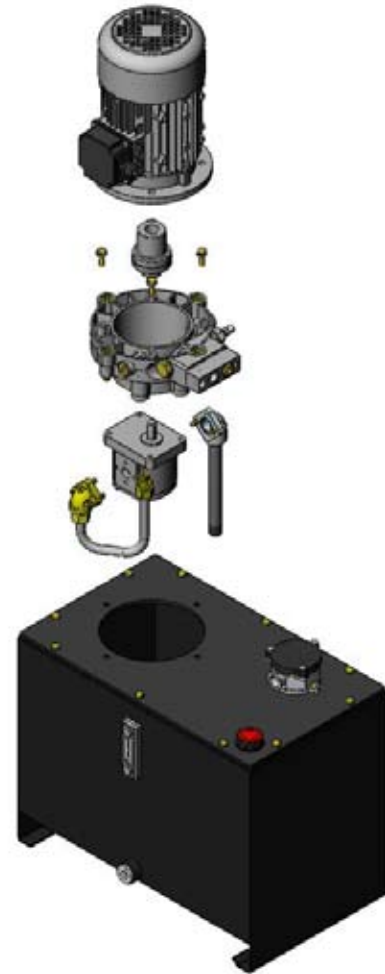

## IM | Oil immersed motor

### Main features:

- AC motors single-phase or 3-phase, 2 or 4 poles up to 5,2 kW for continous duty cycle (S1).
- External gear pumps up to 22,8 cm<sup>3</sup>/rev (1,39 in<sup>3</sup>/rev).
- Pressures up to 300 bar (4350 psi).
- AC electric motor immersed into the oil tank to reduce the space.
- Modular interface on top cover.

### Optionals:

- reversible pump;
- double pump.

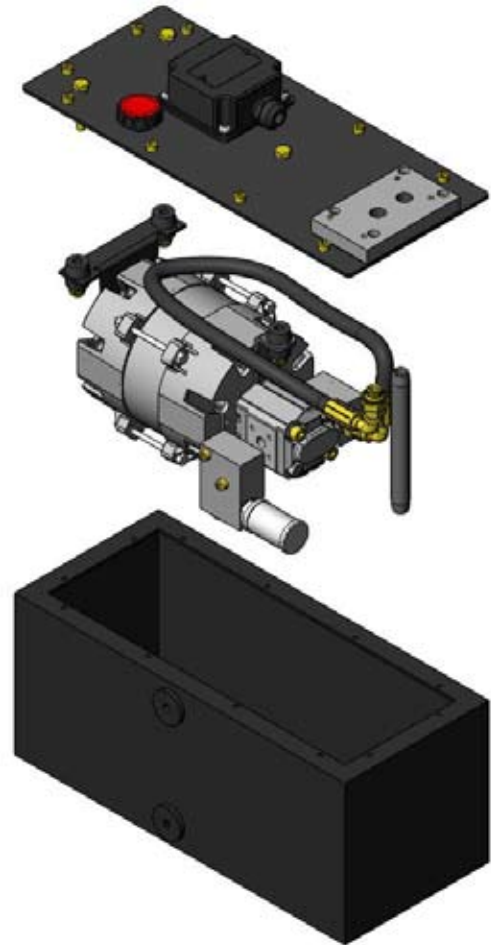

## Examples of hydraulic circuits

The following selection of commonly used hydraulic circuits can be accomplished by the use of the central manifold only.

### 01 Standard circuit

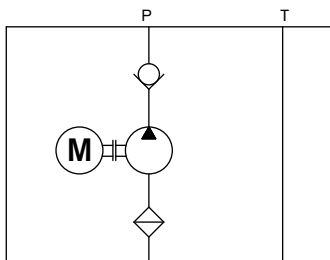

### 02 Reversible pump

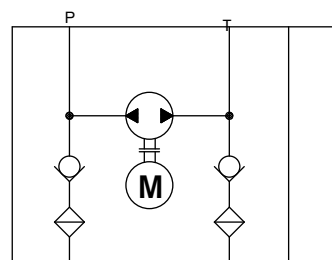

## Modular blocks

More complex driving circuits can be realized with the addition of external blocks over the central manifold.

All the blocks have the same interface with a given distance between P - T ports and threads for screws.

Please refer to modular blocks catalogue to learn which type of circuits are available.

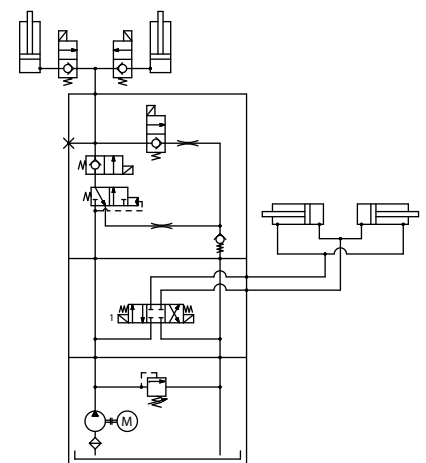
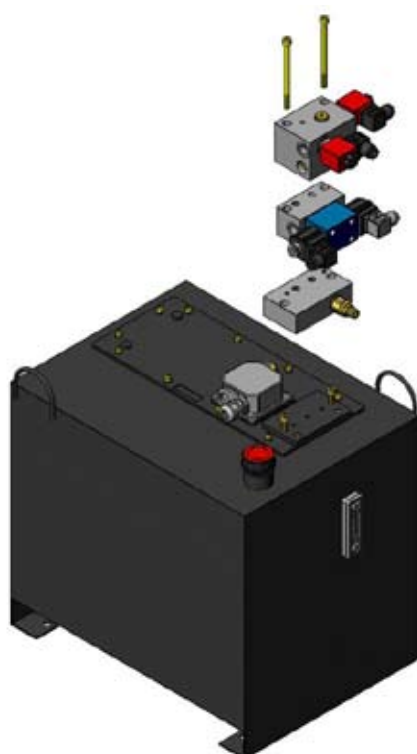

Example: external modular elements with cartridge valves and standard DIN24340-NG6 ISO/CETOP3 valves.

**Reference:** Bosch Rexroth Oil Control  
Oil Sistem Componenti S.p.A.  
via Ragazzi del 99, n. 39  
42100 Reggio Emilia, Italy  
Tel. +39 0522 513 319  
Fax. +39 0522 513 310  
oilsistem@oilsistem.it

**Document no:** RE 00163/08.06

Reprinting or translation, either in whole  
or in part, only with the publisher's  
permission.

Subject to revision.



**Rexroth**  
Bosch Group

Bosch Rexroth Oil Control  
Oil Sistem Componenti S.p.A.  
via Ragazzi del 99, n. 39  
42100 Reggio Emilia, Italy  
Tel. +39 0522 513 319  
Fax. +39 0522 513 310  
[oilssystem@oilssystem.it](mailto:oilssystem@oilssystem.it)